

# MAINTENANCE SERVICE MANUAL

---

## FT-101 SERIES



**YAESU MUSEN CO., LTD.**

C.P.O. BOX 1500  
TOKYO, JAPAN

**YAESU U.S.A.**

17210 Edwards Rd.  
Cerritos, California 90701  
U.S.A.

**FT-101, FT-101B FT-101E  
FT-101EE, FT-101EX**



FT-101



FT-101-B



FT-101-E/EE/EX  
(E MODEL SHOWN)

INDEX

CONTENTS	PAGE
GENERAL	
INTRODUCTION . . . . .	1-0
A BRIEF HISTORY OF THE FT-101 . . . . .	1-1
INSTALLATION NOTES . . . . .	1-4
NORMAL TUNE UP (ABBREVIATED) . . . . .	1-6
TEST SETUP FOR SERVICING . . . . .	1-7
CRYSTAL INFORMATION . . . . .	1-8
SOLDERING/DESOLDERING TECHNIQUE ON PCBA'S . . . . .	1-11
CIRCUIT TRACE REPAIR . . . . .	1-12
PARTS IDENTIFICATION . . . . .	1-14
THEORY OF OPERATION . . . . .	1-15
PLUG IN MODULE CIRCUITS . . . . .	1-26
RECOMMENDED ACCESSORIES . . . . .	1-31
OPTIONAL ACCESSORIES . . . . .	1-39
OPERATING INFORMATION	
CONTROLS AND SWITCHES . . . . .	2-1
REAR APRON CONNECTIONS . . . . .	2-4
FREQUENCY SELECTION . . . . .	2-6
NORMAL TUNE UP . . . . .	2-7
ANTENNAS . . . . .	2-8
ASSEMBLY/INTERCONNECTION	
OUTER COVER REMOVAL . . . . .	3-1
FRONT PANEL REMOVAL . . . . .	3-1
MAIN DIAL ASSEMBLY . . . . .	3-4
SWITCH PANEL ASSEMBLY . . . . .	3-5
PILOT LIGHT REPLACEMENT . . . . .	3-6
VFO REMOVAL . . . . .	3-8
INTERCONNECTIONS BETWEEN FT-101 AND:	
a. FV-101, SP-101P, FL-2000B (or FL-2100) . . . . .	3-9
b. MICROPHONE WIRING . . . . .	3-10
c. FTV-650 (WITH NECESSARY WIRING CHANGES) . . . . .	3-11
d. YC-601, FV-101 . . . . .	3-12
e. FTV-250, FTV-650B . . . . .	3-12
f. FV-101B, SP-101PB, FL-2100B . . . . .	3-12
g. FR-101 . . . . .	3-12
h. YO-100 . . . . .	3-13

INDEX cont'd.

CONTENTS	PAGE
LOCALIZING TROUBLES IN THE UNIT	
FAULT IDENTIFICATION AND LOCALIZATION . . . . .	4-1
SIGNAL TRACING THROUGH THE FT-101 . . . . .	4-2
NOISE BLANKER CIRCUITS . . . . .	4-4
ALC OPERATION . . . . .	4-7
ALC TROUBLESHOOTING . . . . .	4-7
ADVICE ON TROUBLESHOOTING THE FINAL/DRIVER . . . . .	4-11
FINAL AMPLIFIER NEUTRALIZATION . . . . .	4-12
FAULT TREE Rx . . . . .	4-13
FAULT TREE Tx . . . . .	4-14
FT-101 CHASSIS VOLTAGE CHART . . . . .	4-15
FT-101 CHASSIS RESISTANCE CHART . . . . .	4-16
FT-101B/E/EE/EX CHASSIS VOLTAGE CHART . . . . .	4-17
FT-101B/E/EE/EX CHASSIS RESISTANCE CHART . . . . .	4-18
BOARD AND TUBE VOLTAGES . . . . .	4-19
BOARD LOCATIONS - PARTS LOCATIONS	
BOARD/MODULE COMPLEMENT . . . . .	5-1
BREAK IN POINTS OF PCBA CHANGES . . . . .	5-2
BOARD LOCATIONS . . . . .	5-3
VFO UNIT PB1056	
(A) FUNCTIONAL BLOCK DIAGRAM . . . . .	5-5
(B) SCHEMATIC . . . . .	5-6
(C) PARTS LOCATION . . . . .	5-7
MIXER UNIT PB1180/1182	
(A) FUNCTIONAL BLOCK DIAGRAM . . . . .	5-8
(B) SCHEMATIC . . . . .	5-9
(C) PARTS LOCATION . . . . .	5-10
RF UNIT PB1181	
(A) FUNCTIONAL BLOCK DIAGRAM . . . . .	5-11
(B) SCHEMATIC . . . . .	5-12
(C) PARTS LOCATION . . . . .	5-13
LOW FREQUENCY IF UNIT PB1183	
(A) FUNCTIONAL BLOCK DIAGRAM . . . . .	5-14
(B) SCHEMATIC . . . . .	5-15
(C) PARTS LOCATION . . . . .	5-16
MODULATOR UNIT PB1184	
(A) FUNCTIONAL BLOCK DIAGRAM . . . . .	5-17
(B) SCHEMATIC . . . . .	5-18
(C) PARTS LOCATION . . . . .	5-19
NOISE BLANKER PB1292	
(A) SCHEMATIC . . . . .	5-20
(B) PARTS LOCATION . . . . .	5-21
POWER REGULATOR UNIT PB1314	
(A) SCHEMATIC . . . . .	5-22
(B) PARTS LOCATION . . . . .	5-23
AUDIO UNIT PB1315	
(A) FUNCTIONAL BLOCK DIAGRAM . . . . .	5-24
(B) SCHEMATIC . . . . .	5-25
(C) PARTS LOCATION . . . . .	5-26

INDEX cont'd.

CONTENTS	PAGE
RF SPEECH PROCESSOR PB1494	
(A) SCHEMATIC . . . . .	5-27
(B) PARTS LOCATION . . . . .	5-28
RF SPEECH PROCESSOR PB1534	
(A) SCHEMATIC . . . . .	5-29
(B) PARTS LOCATION . . . . .	5-30
REGULATOR AND CALIBRATOR UNIT PB1547	
(A) FUNCTIONAL BLOCK DIAGRAM . . . . .	5-31
(B) SCHEMATIC . . . . .	5-32
(C) PARTS LOCATION . . . . .	5-33
NOISE BLANKER UNIT PB1582	
(A) FUNCTIONAL BLOCK DIAGRAM . . . . .	5-34
(B) SCHEMATIC . . . . .	5-35
(C) PARTS LOCATION . . . . .	5-36
MAIN CHASSIS UNITS	
(A) RF TRIMMER BOARD PB1186 . . . . .	5-37
(B) TRIMMER BOARD A, PB1187 . . . . .	5-37
(C) TRIMMER BOARD B, PB1092 . . . . .	5-37
(D) ANTENNA TRAP BOARD PB1116 . . . . .	5-37
(E) CRYSTAL BOARD PB1073 . . . . .	5-38
(F) RECTIFIER BOARD PB1076B . . . . .	5-38
(G) PB1076B PARTS LOCATION . . . . .	5-39
(H) TRAP BOARD PB1109 . . . . .	5-40
(I) COIL BOARD A, PB1083 . . . . .	5-40
(J) COIL BOARD E, PB1166 . . . . .	5-40
(K) DIODE SWITCH BOARD PB1186 . . . . .	5-40
MODIFICATIONS	
INSTALLATION OF RF PROCESSOR TYPE B INTO EE/EX . . . . .	6-1
INSTALLATION OF RF PROCESSOR INTO LATE 101 AND B . . . . .	6-12
CW FILTER INSTALLATION . . . . .	6-14
FT-101 SERIES (ALL) AM MODIFICATION . . . . .	6-16
FT-101EX DC-DC CONVERTER INSTALLATION . . . . .	6-17
HUM PROBLEMS IN EARLY FT-101 . . . . .	6-20
HUM PROBLEMS IN LATER FT-101B/E/EE/EX . . . . .	6-21
NOISE POP MODIFICATION . . . . .	6-23
MODIFIED FAN HOOKUP . . . . .	6-24
PB1582 NOISE BLANKER MODIFICATION . . . . .	6-25
FAN INSTALLATION FOR FT-101/FT-101B (220V FAN) . . . . .	6-26
FAN INSTALLATION FOR FT-101E/EE/EX (100V FAN) . . . . .	6-28
MODIFICATION FOR FSK OPERATION . . . . .	6-29
POWER TRANSFORMER CONNECTIONS . . . . .	6-30
MODIFICATION FOR NON-STANDARD FREQUENCIES . . . . .	6-31

INDEX cont'd

CONTENTS	PAGE
ALIGNMENT	
WARNING AND CAUTION NOTICE . . . . .	7-1
EQUIPMENT REQUIRED . . . . .	7-1
ALIGNMENT PROCEDURE, Tx AND Rx . . . . .	7-2
TRAP COIL ALIGNMENT . . . . .	7-7
HETERODYNE CRYSTAL OSCILLATOR ALIGNMENT . . . . .	7-8
"S" METER ADJUSTMENT . . . . .	7-9
NOISE BLANKER ADJUSTMENT . . . . .	7-9
SIDETONE LEVEL ADJUSTMENT . . . . .	7-9
VOX ADJUSTMENT . . . . .	7-9
CARRIER BALANCE NULLING . . . . .	7-10
ALC LEVEL ADJUSTMENT . . . . .	7-10
RF PROCESSOR . . . . .	7-10
BIAS ADJUSTMENT . . . . .	7-11
FINAL AMPLIFIER NEUTRALIZATION . . . . .	7-11
POWER OUTPUT (PO) ADJUSTMENT . . . . .	7-12
BAND PASS FILTER ADJUSTMENT . . . . .	7-17
PARTS LISTS & ORDERING DATA	
PARTS ORDERING DATA . . . . .	8-1
PARTS LIST FT-101 . . . . .	8-3
PARTS LIST FT-101B . . . . .	8-7
PARTS LIST FT-101E/EE/EX . . . . .	8-12

SCHEMATIC DIAGRAMS - SECTION 9

GENERAL

SECTION 1

CONTENTS	PAGE
INTRODUCTION . . . . .	1-0
A BRIEF HISTORY OF THE FT-101 . . . . .	1-1
INSTALLATION NOTES . . . . .	1-4
NORMAL TUNE UP (ABBREVIATED) . . . . .	1-6
TEST SETUP FOR SERVICING . . . . .	1-7
CRYSTAL INFORMATION . . . . .	1-8
SOLDERING/DESOLDERING TECHNIQUE ON PCBA'S . . . . .	1-11
CIRCUIT TRACE REPAIR . . . . .	1-12
PARTS IDENTIFICATION . . . . .	1-14
THEORY OF OPERATION . . . . .	1-15
PLUG IN MODULE CIRCUITS . . . . .	1-26
RECOMMENDED ACCESSORIES . . . . .	1-31
OPTIONAL ACCESSORIES . . . . .	1-39

For Service Manuals Contact  
MAURITRON TECHNICAL SERVICES  
8 Cherry Tree Rd, Chinnor  
Oxon OX9 4QY  
Tel:- 01844-351694 Fax:- 01844-352554  
Email:- enquiries@mauritron.co.uk

## INTRODUCTION

The purpose of this manual is to provide the reader with the essential information that is needed to keep his FT-101 (of whatever vintage) running at top efficiency. While I have made an effort to include many technical details where it was felt desirable, this manual is written toward the serviceman/owner, rather than the engineer/ designer.

Use of this manual is entirely at the user's risk. We believe that the information herein is accurate and factual, but should damage to your equipment occur, or erroneous data be present, we assume no liability for such damage or erroneous information.

No manual, no matter how well written, detailed, or carefully edited, can take the place of experience and judgement.

For this reason, we have departed from the traditional "military format" in writing technique and the style may seem too informal on first reading, however, remember that our goal was to make this manual easy to use.

You will find inside these covers, not just a list of clipped out circuit descriptions and re-drawn prints, but all the tricks and neat stuff that the factory developed - extras that never show up in operator's manuals, such as part location data, test points, a wealth of "How To Do It" instructions, and the special information our service files contained.

We are grateful to the many Yaesu factory people and dealers servicemen, all of whom contributed freely of their time and effort to make this manual a useful tool.

As the Author/Editor, I hope you find it is worth double what it cost you, and that you seldom have need for it, except to better understand - THE RADIO.

VY 73,



Bernard E. Tower, W6RNW  
General Manager  
Yaesu Electronics Corp., USA



A BRIEF HISTORY OF THE FABULOUS FT-101  
THE RADIO

The FT-101 series of transceivers appeared initially in the USA in small numbers in late 1971, and gained almost overnight approval of amateur radio operators for their quality of signal, flexibility of operation and the professional attention given to workmanship and design.

Early FT-101's (serial numbers 25,000 and below) were produced to meet the following specifications:

FREQUENCY RANGE:	3.5-30 MHz amateur bands (80-10 m) 26.9-27.5 MHz (CB) 10-10.5 MHz (WWV)
TYPE OF EMISSION:	USB or LSB (selectable) CW or AM
POWER INPUT:	SSB 260 watts PEP CW 180 watts, 50% duty cycle AM 80 watts (slightly lower on 10 m)
CARRIER SUPPRESSION:	50 dB
UNWANTED SIDEBAND SUPPRESSION:	50 dB at 1000 Hz
SPURIOUS RADIATION:	Down 40 dB or more
TRANSMITTER FREQUENCY RESPONSE:	300 Hz to 2700 Hz $\pm$ 3 dB
DISTORTION PRODUCTS:	Down 30 dB or more
ANTENNA OUTPUT IMPEDANCE:	50-75 Ohm unbalanced
FREQUENCY STABILITY:	Less than 100 Hz drift in any 30 minute period
SENSITIVITY:	0.3 microvolt, S/N 10 dB
AUDIO OUTPUT:	3 watts
POWER CONSUMPTION:	AC Rx 35 watts, Tx 300 watts DC 12V standby 0.5 amp transmit 20.0 amp
WEIGHT:	30 Lbs
DIMENSIONS:	13½ x 6 x 11½

Each transceiver shipped is normally accompanied by an instruction manual, a set of accessory plugs, a high impedance (50K) dynamic hand mike, and two cables; one for AC operation, the other for DC power hookup. The exception is the FT-101EX, which has no DC capability, although it can be added by installing the DC-1 unit. The installation of the DC-1 is also covered in this manual.

These specifications differ from the latest issue FT-101E series only in the frequency range (which now includes the 160 meter band) so the owner of a vintage Yaesu FT-101 should not feel he was obsoleted too badly along the way, but newer FT-101's did include major circuit improvements.

For example, Yaesu engineers developed a major modification that significantly improved the receiver side of the early FT-101, and after serial numbers 25,000 - all FT-101's came from the factory with some different boards and circuits than early models. This led to a situation where two different models existed side by side, with the same FT-101 designation, so in this manual, pre S/N 25,000 units are identified as "early", and post S/N 25,000 as "late". (We only use the last five digits of the Yaesu serial number - the other numbers and letters are used for internal factory control).

The entire modification which made an "early" into a "late" was developed and sold as an update kit, which included a 25 page instruction guide, complete with pictures and sketches.

Total confusion promptly occurred, with hams ordering the kit (known as the MIR-1 Modification Kit) who unhappily did not have the test equipment necessary to do the re-alignment, or just plain lacked the "know how" to do such major surgery on a sophisticated electronic assembly.

After fighting the flood for a few months, Yaesu withdrew the kit from the open market, and today will only install it at their factory.

There was no FT-101A produced, but when the second set of major mods appeared, the new issue was designated FT-101B, to emphasize its model change, including all of the updated circuitry, plus adding a new band; 160 meters. All FT-101B's and "E's" will work on the 160 meter band, but you may have to order a crystal, etc.

The FT-101B was superseded by the FT-101E, which included an RF Speech Processor; the FT-101EE which omitted the Speech Processor; and an "AC Base" version, FT-101EX which did not have the built-in DC supply, Speech Processor, DC cord, microphone, or 160m crystal.

Again, no FT-101C, or D versions reached production status.

**For Service Manuals Contact**  
**MAURITRON TECHNICAL SERVICES**  
8 Cherry Tree Rd, Chinnor  
Oxon OX9 4QY  
Tel: 01844-351694 Fax: 01844-352554  
Email: enquiries@mauritron.co.uk

Early FT-101E's used a Speech Processor that had to be set manually on each band for clipping level, which meant considerable cover lifting for the amateur who switched bands frequently. To eliminate this handicap, the processor level control was combined with the clarifier pot using a paddle knob. At the same time, the processor itself underwent a redesign, and emerged as an extremely low distortion producing RF processor, noticeably superior to both previous Yaesu processors, and competitive units.

So in a few short paragraphs, we have broadly outlined the history of the FT-101 series of Yaesu equipment. We could go on with stories of sea rescues, contest winners, emergency and disaster activities in which the FT-101 proved again and again, that for serious communications work, Yaesu is:

"THE RADIO"

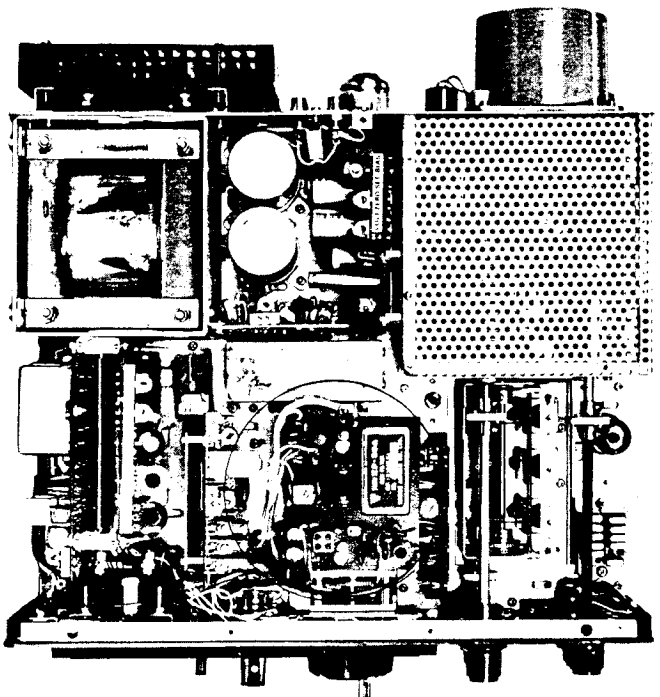

Built in R.F. Speech Processor

Fig. 1-1

**Features**

- \* Built-in AC & DC power supplies
- \* Built in RF-speech Processor for increased talk power (E model only)
- \* 260 Watts PEP SSB, 180 Watts CW, & 80 Watts AM.
- \* Factory sealed, solid state VFO for optimum stability and accurate 1 KHz readout
- \* Effective Noise Blanker, threshold adjustable, for elimination of noise spikes
- \* Built-in, fully adjustable VOX
- \* Automatic break-in CW operation with sidetone
- \* Selectable 25 KHz and 100 KHz calibrator
- \* ±5 KHz receiver clarifier w/separate ON/OFF switch
- \* Built-in WWV/JJY reception
- \* Heater switch to shut off final tubes for conservation of current drain
- \* Reliable easy to operate lever switch
- \* Adjustable carrier level for tune-up and novice operation
- \* Built-in speaker
- \* High-Q, permeability tuned, RF stages to provide the performance required even in base station operation.
- \* Includes dynamic, hand-held type microphone
- \* Indicator lights for internal VFO and clarifier operation
- \* Eight pole SSB filter for unparalleled selectivity on today's crowded bands
- \* All mode operation – SSB, CW, & AM
- \* Built-in internal crystal control provision and Dual VFO adaptor
- \* Complete line of compatible accessories for flexible station design

## INSTALLATION NOTES

The FT-101 was designed to operate primarily as a desk top unit, however, addition of a mobile mounting and a cable/plug change, will allow it's successful use as a highly effective mobile unit. Two pre-wired plugs are furnished with each unit, one for AC, the other for DC use. The DC cable wire is: red = positive, black = negative.

The connector itself should be substituted only with great caution, since the pin numbering of Cinch-Jones and other USA version connectors is different from the original Yaesu supplied assembly. The USA connector versions will fit, but great care should be used in the wiring.

Should you encounter a transceiver with a problem of blowing it's fuse (or the house fuse) whenever it is plugged in, don't overlook the connector. If it is Amphenol, or Cinch-Jones, verify that it has been wired correctly - or better, substitute a known-to-be-good cable/connector assembly.

POWER PLUG COMPARISON		
YAESU		CINCH-JONES
PIN NO. 1	3	3
2	2	2
3	1	1
4	6	6
5	5	5
6	4	4
7	9	9
8	8	8
9	7	7
10	12	12
11	11	11
12	10	10

3	2	1
6	5	4
9	8	7
12	11	10

1	2	3
4	5	6
7	8	9
10	11	12

Fig. 1-2

Try to install the unit in a cool area, and don't impede the air flow/circulation through the unit by putting books, papers, or other equipment on top of the case. The FT-101 is rugged as the dickens, but like all solid state devices it does not like to be overheated.

So, avoid hot air vents, steam radiators or Southern California direct sunlight, and your unit will go for years without trouble. If your ambient temperature is normally 95 degrees F. or higher, a fan (FA-9) is often an excellent investment.

**For Service Manuals Contact**  
**MAURITRON TECHNICAL SERVICES**  
 8 Cherry Tree Rd, Chinnor  
 Oxon OX9 4QY  
 Tel:- 01844-351694 Fax:- 01844-352554  
 Email:- enquiries@mauritron.co.uk

A good all Yaesu station set-up is shown below - (The United Nations Station K2UN, in New York).



Fig. 1-3

Mobile installations should also be done with some consideration given to heat dissipation and build-up. Don't run the vehicle heater output onto the rig, or onto the converter transistors.

Maritime mobile installations rarely have heat build-up problems, but antenna matching and loading almost always requires a match box set-up and serious antenna work in order to achieve good efficiency, and low SWR.

Mount the unit so it is mechanically secure and shielded from water splashes, slush or dust build-up.

Vacuum the unit occasionally and clean up any dirt accumulations. (Dust and dirt act as insulators, and will cause heat build-up).

## NORMAL TUNE UP (ABBREVIATED)

The following technique is recommended to avoid damage to your final amplifier section, and to prolong the life of your transmitting tubes.

1. All tuning should be performed at low power. The following procedure is recommended for all models and versions.
  - A. Peak the preselector on the unit for maximum noise on receive.
  - B. Place the meter in the IC position, and the mode switch in the tune position.
  - C. Rotate the carrier control to the fully counter clockwise (minimum) position.
  - D. Key the mike and increase the setting of the carrier using the carrier control knob, until the current is increased 50 ma above idle. (The idle current should be 60 ma, so your meter should now indicate 110 ma).
  - E. Switch the meter to the P0 position.
  - F. Adjust plate tuning, loading and preselector for maximum meter reading.
  - G. Release the mike button and rotate the carrier control to the 3/4 clockwise position.
  - H. IMPORTANT: In the following steps, tune time should not exceed a 10 second interval. We recommend at least 20 seconds between such tune periods. With familiarity of the procedure complete tuning can be accomplished within a single 10 second period.
  - I. Key mike and repeak plate tuning and loading for maximum P0 indication. 10 SECONDS MAXIMUM.
  - J. This completes the tune up. Set the mode switch to the desired mode and adjust the mic gain for proper ALC meter indication.
2. Do not exceed the recommended plate current (IC).
3. Do not exceed the recommended continuous plate current for AM or RTTY.
4. Do not use antennas which are non-resonant or exhibit an SWR of more than 2:1, at the frequency used for operation.

5. Do not replace driver or final tubes with other than factory brands. (6KD6, 6JS6, and 12BY7A should be TOSHIBA or MATSUSHITA, 6GK6 should be G.E.)
6. Always re-neutralize the finals whenever tubes are replaced.
7. Do not set books or other units on top of the transceiver. This prevents proper cooling.
8. Remember that specified power is "input power" and that the output will be considerably less than this figure. Under continuous carrier applications such as AM or FSK, the output is around 25 watts for the FT-101. (IC 150 ma)

TYPICAL TEST SET-UP FOR SERVICING

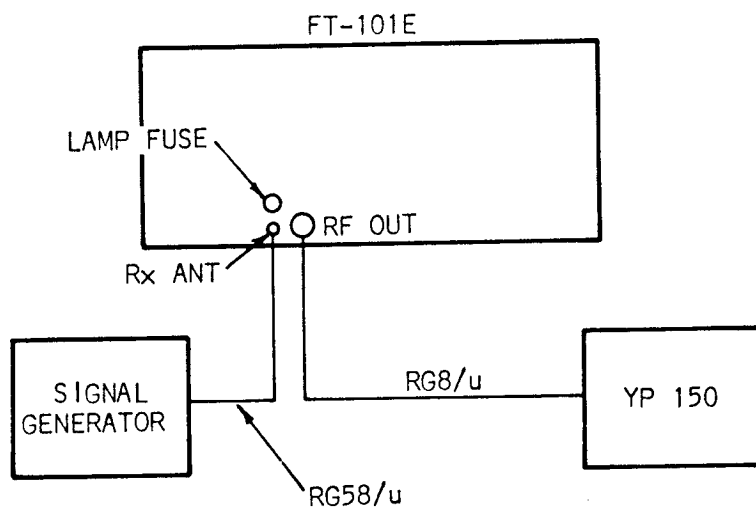

Fig. 1-4

For Service Manuals Contact  
**MAURITRON TECHNICAL SERVICES**  
 8 Cherry Tree Rd, Chinnor  
 Oxon OX9 4QY  
 Tel:- 01844-351694 Fax:- 01844-352554  
 Email:- enquiries@mauritron.co.uk

## CRYSTAL INFORMATION

Crystals for the FT-101 series are all made to the same specifications, so the correlation data below applies to all versions:

FUNCTION	HOLDER	FREQUENCY RANGE (kHz)	MODE	LOAD C (pf)	SERIES R (OHMS)
Band	HC-25/U	7520	F	25	20
Band	HC-25/U	9520	F	21	20
Band	HC-25/U	13020	F	19	20
Band	HC-25/U	16020	F	20	20
Band	HC-25/U	20020-35520	3rd overtone	20	45
Carrier	HC-6/U	3178.5 (USB)	F	36	50
Carrier	HC-6/U	3181.5 (LSB)	F	39	50
Carrier	HC-6/U	3179.3 (CW)	F	34	50
Marker	HC-13/U	100	F	65	1.5K
Marker	HC-6/U	3200	F		
Fixed	HC-25/U	8.7-9.2 Range	F	50	20
Fixed	HC-6/U	8.7-9.2 (Early Model)	F	20	20

To correctly determine the crystal frequency for a fixed frequency within a band, use the formula:  $F_x = (F_1 + F_c) - F_o$  where:

$F_1$  = Band crystal in kHz

$F_x$  = Crystal frequency

$F_o$  = Desired operating frequency

$F_c$  = One of the three frequencies below

3181.5 for LSB

3178.5 for USB

3179.3 for AM or CW



To simplify matters, the values of  $(F_1 + F_c)$  are given below for the bands that are normally installed when the FT-101 leaves the factory, but should you want to set up your FT-101 for out-of-band (Mars-Cap etc.) use the formula.

BAND	LSB	USB	AM/CW
160m	10701.5	10698.5	10699.3
80	12701.5	12698.5	12699.3
40	16201.5	16198.5	16199.3
20	23201.5	23198.5	23199.3
15	30201.5	30198.5	30199.3
11	36201.5	36198.5	36199.3
10A	37201.5	37198.5	37199.3
10B	37701.5	37698.5	37699.3
10C	38201.5	38198.5	38199.3
10D	38701.5	38698.5	38699.3

Since the FT-101 tunes 500kc segments, the band crystals must be chosen so that the desired frequency is contained within a segment beginning with either zero, (0) or (.5).

For example, a band crystal for an operating frequency of 8228.3 mHz would require coverage from 8.0 mHz to 8.5 mHz.

Add 6.02 to the lower frequency (8.0) and the resultant will be the band crystal frequency. In this case, 14.02 mHz.  $(8.0 + 6.02)$

Second example, to operate on 22.733 mHz, add 6.02 to 22.0 = 28.02. (Clue: Your band crystals will always end in either .52 or .02).

Two exceptions exist - the FT-101 series will not function from 2.0 to 3.5 mHz (balance modulator frequencies) or 5.5 to 7.0 mHz (too close to the IF frequency).

With those exceptions, the FT-101 series can be made operational anywhere within the 1.8 to 30 mHz HF band at full efficiency, but re-tuning of the coils for the new setup will be necessary.

The chart below shows the crystals that the factory supplied, and the various optional crystals that are available, but were not part of the original manufacture.

	FT-101(Late FT-101B)	FT-101E	FT-101EE	FT-101EX
160m Band Crystal	X	0	0	X
80m " "	0	0	0	0
40m " "	0	0	0	0
20m " "	0	0	0	0
15m " "	0	0	0	0
11m** " "	0	0	0	0
10m A " "	0	0	0	X
10m B " "	0	0	0	0
10m C " "	0	0	0	X
10m D " "	0	0	0	X
WWV/JJY** "	0	0	0	X
Marker "	0	0	0	0
Fixed Freq. " (Ch1/Ch2)	X	X	X	X
CW Filter	X	X	X	X
RF Speech Processor Fixed Frequency Module	not available	0	X	X
DC-DC Converter	0	0	0	X
Cooling Fan	X	X	X	X
Microphone	0	0	0	X

0 = Installed

X = Optional - Not Installed

\*\* = Receive Only

For Service Manuals Contact  
**MAURITRON TECHNICAL SERVICES**  
 8 Cherry Tree Rd, Chinnor  
 Oxon OX9 4QY  
 Tel: 01844-351694 Fax: 01844-352554  
 Email: enquiries@mauritron.co.uk

## SOLDERING AND DESOLDERING TECHNIQUE ON PCBA'S

The FT-101 circuit boards are tough, but not indestructable. The most common damage we find when examining customer repairs is overheating the circuit trace, which "lifts" the trace and makes a fragile, highly unreliable connection.

Avoiding this situation is best, so get the right equipment on hand first, and read over these Do's and Don'ts.

Don't use a flame or high wattage iron - it burns things irreparably.

Do .. use a 12 watt to 30 watt chisel tip iron.

Don't use an iron that plugs directly into the wall with only two wires.

Do .. use an isolated (through a transformer) or 3 wire grounded tip iron. (Accidently passing 110 VAC through our transistor circuitry by using a 10 year old soldering iron with the hot leg on the tip has caused many \$100.00 repair bills).

Don't use acid core solder (Yes, we still see it happening).

Do .. use 60/40 rosin core solder (and for heavens sake, be neat).

Don't try to heat the pad and shake or blow the solder out.

Do .. use a solder sucker and solder tape to clean up the holes.

Don't panic if you lift a trace (we will tell you later how to rework PCBA's).

Do .. a super good job and take pride in your work!

# CIRCUIT TRACE REPAIR

Most of the printed (plated) circuit board assemblies (PCBA's) appear in FT-101's in only single sided versions, however, certain boards such as PB-1292 and PB-1181, use a double sided board for the shielding it provides. The terminology we will use is explained by the sketches:

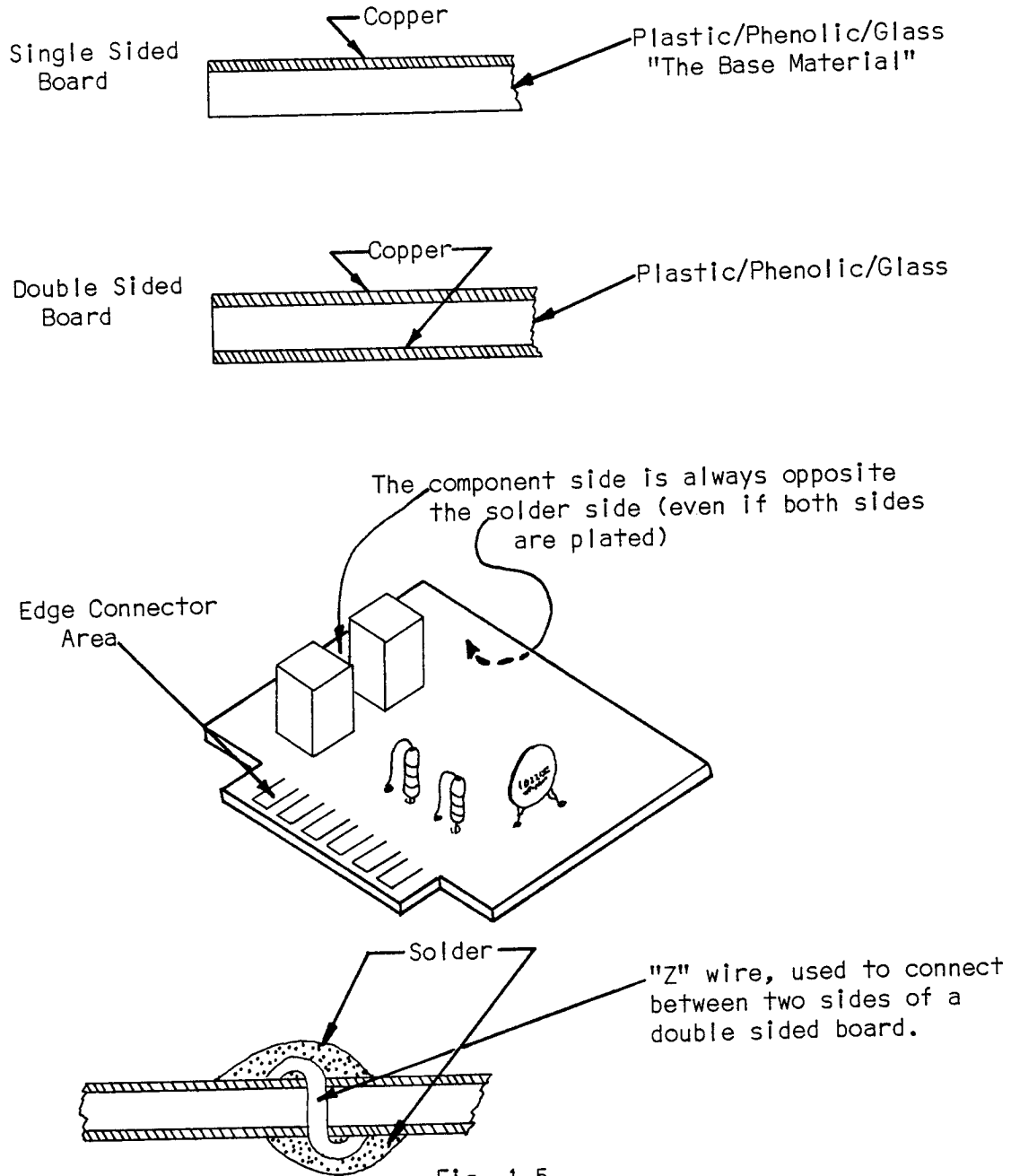

Fig. 1-5

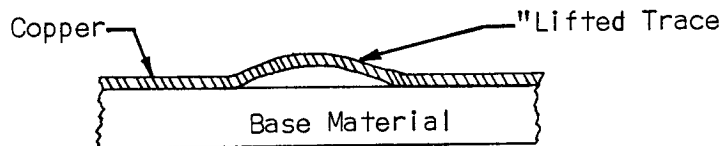
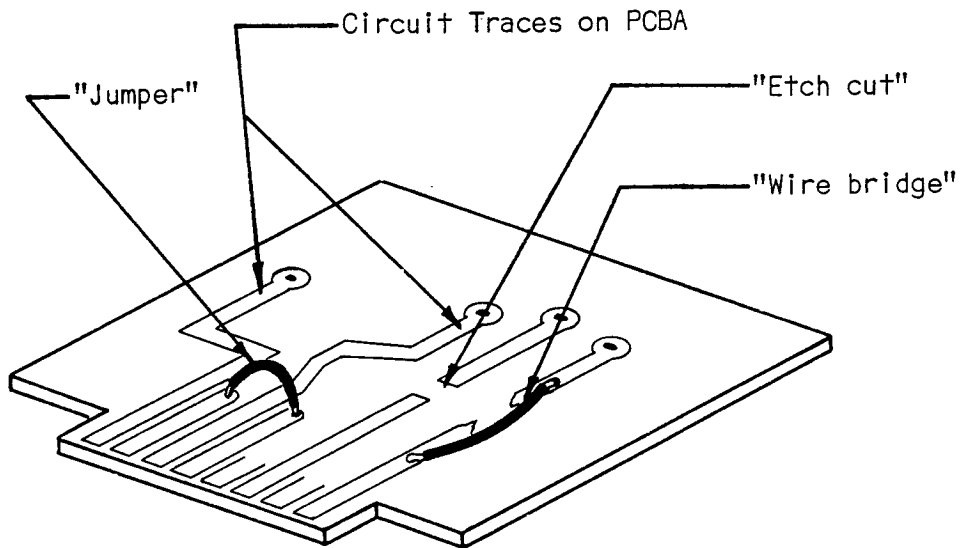

Fig. 1-6

Sometimes, after the designers and draftsmen have finished the artwork and tape up, a board is made with an error in it. (This is being charitable - managers have been known to faint dead away when first informed of this kind of development). Thus etch cuts and jumpers at the factory level usually represent the "fine tuning" of a design, and they are best left in place, unless you enjoy improving the design engineers effort. In that case, you should know how to cut a trace professionally.

Like this:

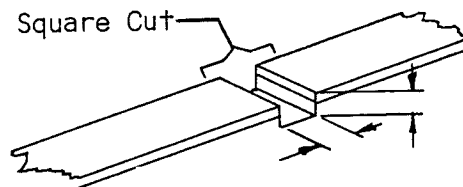

Fig. 1-7

Coat Cut Area With Eastman 910

For Service Manuals Contact  
**MAURITRON TECHNICAL SERVICES**  
 8 Cherry Tree Rd, Chinnor  
 Oxon OX9 4QY  
 Tel: 01844-351694 Fax: 01844-352554  
 Email: enquiries@mauritron.co.uk

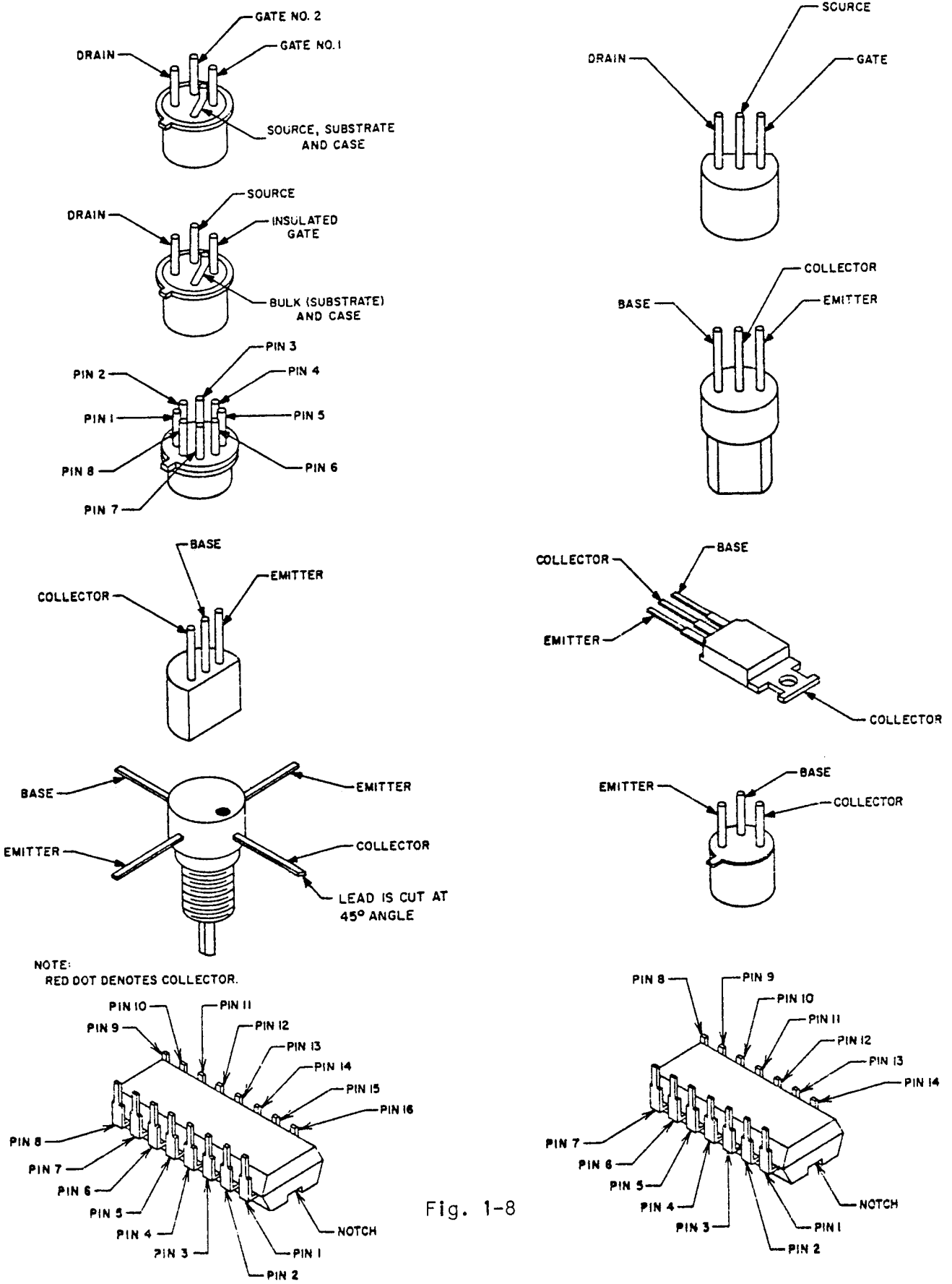

Fig. 1-8

## THEORY OF OPERATION

### PLUG-IN MODULES

The transceiver is designed with computer type plug-in modules. These modules are: high frequency unit, high frequency IF unit, low frequency IF unit, audio unit, modulator unit, noise blanker unit and power regulator unit. (See Fig. 1-9) The VFO unit, the crystal oscillator unit and rectifier unit are built into the main chassis, but are on PCBA boards.

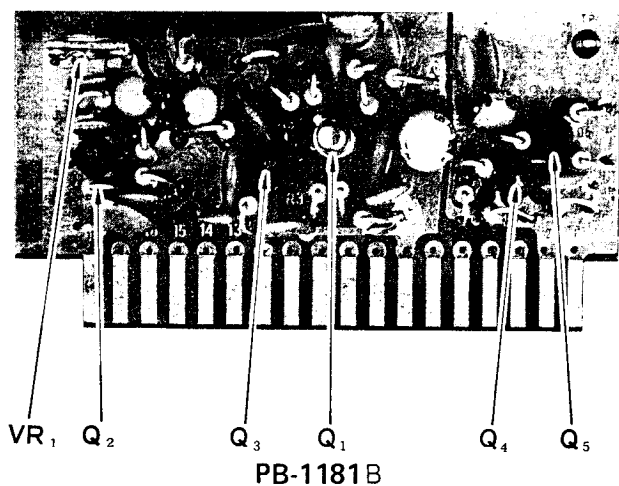

Fig. 1-9

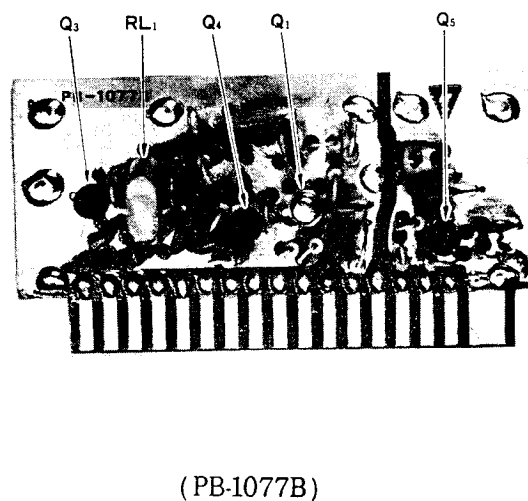

Fig. 1-10

### HIGH FREQUENCY UNIT (PB1181)

This module contains the receiver RF amplifier, receiver 1st mixer, transmitter 2nd mixer and heterodyne oscillator circuit. The signal from the antenna coil is fed to the gate of Q1 (field effect transistor 3SK40M) through terminal 8 of the module.

The AGC (automatic gain control) voltage, which is obtained from the low frequency IF unit, is applied to the gate circuit of Q1 from pin 9 to control the gain of this stage. A manual RF gain control on the front panel is connected to the source of Q1 through pin 10.

Signal output from the Q1 is then coupled to the receiver 1st mixer Q2 (2SK19GR) where the incoming signal is mixed with a signal from the heterodyne oscillator Q4 (2SC372Y) through the buffer stage Q5 (2SC373). The product of the 1st mixer is applied through pin 17 to the high frequency IF unit.

Transmitter signal is fed to the base of transmitter 2nd mixer Q3 (2SC784R) from pin 13. The signal from the heterodyne oscillator is applied to the emitter of the mixer Q3, through the buffer stage Q4 (2SC372Y). This converts the high frequency IF signal to the desired transmitting frequency. This transmitting signal is fed to T102 through pin 11. The gate circuit of the receiver mixer Q2 is disconnected in transmit by a diode switch to avoid the lowering the Q of the circuit. Crystal sockets and all coils are mounted on the main chassis.

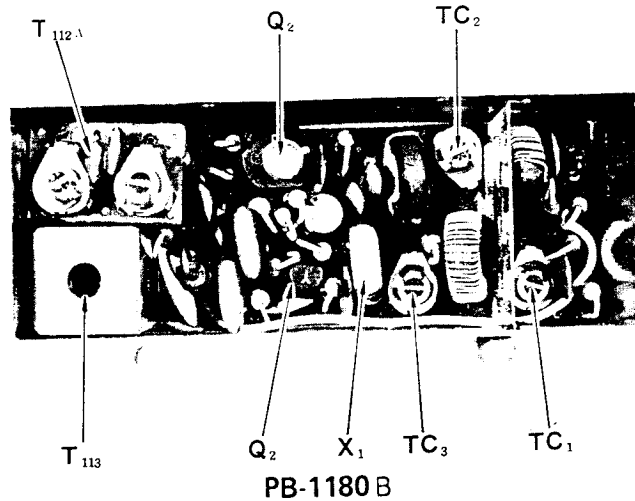

For Service Manuals Contact  
**MAURITRON TECHNICAL SERVICES**  
 8 Cherry Tree Rd, Chinnor  
 Oxon OX9 4QY  
 Tel:- 01844-351694 Fax:- 01844-352554  
 Email:- enquiries@mauritron.co.uk

Fig. 1-11

HIGH FREQUENCY IF UNIT (PB1180)

The module contains the transmitter 1st mixer Q1 (2SC372Y), the receiver 2nd mixer Q2 (3SK40M) and the 5520 to 6020 kHz bandpass network. The signal from the receiver 1st mixer is fed to the gate of the mixer through the bandpass network L1, L2, and L3 from pin 15. VFO voltage is also applied to the 2nd gate of Q2 from pin 11. The signal is converted to 3180 kHz low frequency IF and fed to the following stage through pin 3 to output transformer T112A. On transmit, the 3180 kHz signal is fed to the base of the mixer from pin 5. A 14 mHz trap coil T113 is connected to the base circuit of Q1. The VFO signal is fed to the emitter of the Q1 which produces the 5520 to 6020 kHz high frequency IF signal. This signal is fed to the following stage from pin 16 through the bandpass network.



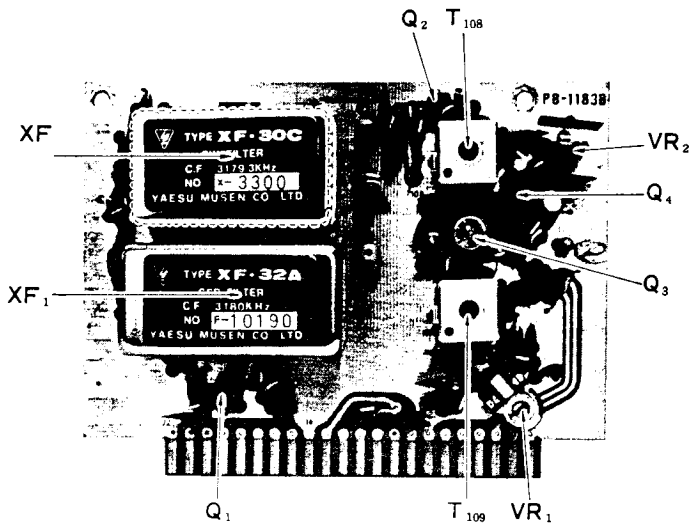

PB-1183B

Fig. 1-12

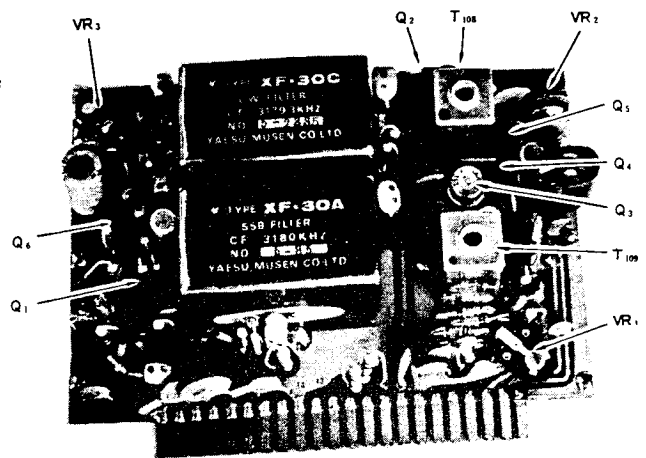

(PB-1080A)

Fig. 1-13

### LOW FREQUENCY IF UNIT (PB1183)

This module contains the low frequency IF amplifier, crystal filter, detector and AGC/S meter circuits.

On receive, a 3180 kHz signal from the noise blanker circuit is fed to the gate of Q1 (2SK19GR), FET from pin 15 of the module. This signal is also fed out through C3 to pin 17, where it appears at J7 as "IF OUT" drive for a pan adapter or other high gain display.

D1-D4 are diode switches which select the crystal filter for SSB or CW reception. The 600 Hz CW filter XF-30C is an optional feature available at additional cost from your dealer. The diode switch selects the CW filter automatically when the MODE switch is set to CW position. This control voltage is derived from pin 9 and 12. A modification is possible, (see modification section) using an XF-30B filter which will provide a 6 kHz wide bandpass for AM reception. The hitch of course is that only two filter positions are provided on PB1183B, so you can have either AM and no CW filter, or vice-versa.

The signal from the selected crystal filter is fed to the base of Q2, (2SC784R) and is amplified by Q2 and Q3, (CA3053) integrated circuit. The gain of these two stages is controlled by the AGC voltage derived from AGC amplifier Q4 (2SC828Q). The gain can also be controlled manually by the RF gain control on the front panel.

The output from Q3 is fed through T109 to the ring demodulator D8-D11 for CW and SSB reception. The carrier signal is fed to the detector from pin 5. The carrier signal is balanced by VR1 to obtain minimum distortion and also to avoid an S-meter reading which could be influenced by the carrier oscillator signal. AM signals are detected by D7 (1S1007) and fed to an audio amplifier stage from pin 4 through the MODE switch. The detected audio signals are connected to the audio amplifier unit (PB1315) from pin 4 (AM) and pin 6 (SSB and CW) via the MODE switch on the front panel.

D5 (1S1007) and D6 (1S1555) are the AGC rectifiers which provide drive to the AGC amplifier Q4 (2SC828Q). The emitter of Q4 controls S-meter amplifier Q5, another (2SC828Q).

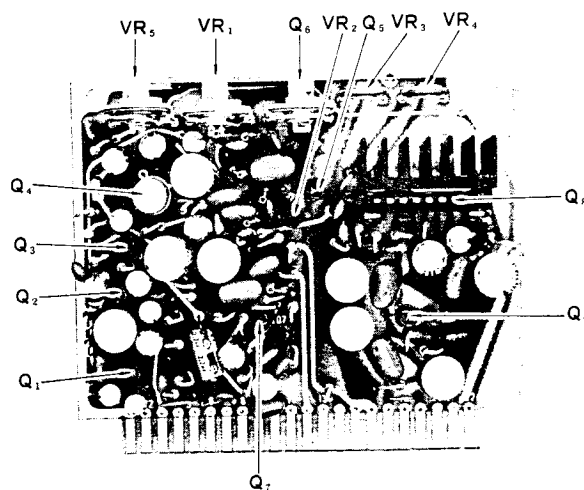

PB-1315

Fig. 1-14

#### AUDIO UNIT (PB1315)

This module contains the microphone amplifier, receiver audio amplifier, VOX amplifier and CW sidetone oscillator on transmit. A speech signal from the microphone is fed to the first MIC amplifier Q1 (2SK19GR) FET from pin 5. Input impedance of the MIC amplifier is nominally 50K ohms. The input microphone signal is controlled in amplitude by the MIC GAIN control, which is between pins 3 and 4. The second microphone amplifier Q2, (2SC372Y) amplifies and is applied to the emitter follower Q3, (2SC372Y) to be delivered to the modulator unit from pin 8.

The received audio signal from the AUDIO GAIN control is applied through pin 19 to a pre amplifier Q9, (2SC1000) and amplified by integrated circuit Q8, (AN214). This stage, in turn, increases the signal to speaker level.

The audio power amplifier circuit utilizes an output transformer less (OTL) circuit and can deliver 3 watts of audio output to the speaker through pin 22.

In the VOX MODE, the signal from the first microphone amplifier is coupled through the VOX GAIN control potentiometer VR1 to VOX amplifier Q4, (TA7042M). The audio signal amplified by Q4 is then fed to the VOX rectifiers, 103 and 104 (1S1555). The positive DC output voltage of the rectifier is then applied to the gate of the VOX relay control transistors Q5, (2SK19Y) and Q6 (2SC373) causing them to conduct and actuate the VOX relay (RL1) on the main chassis. The collector circuit of Q6 is connected in series with RL1 through pin 13, and S7.

The ANTITRIP circuit provides a bucking voltage to prevent the speaker output from tripping the transceiver into the transmit function. A small portion of the receiver audio is taken from pin 1 of Q8 (AN214) through VR5 to the input of the anti-trip amplifier Q4 (TA7042M), and fed to rectifiers D1 and D2 (1S1555), providing a negative DC output voltage which is connected to the gate of Q5 (2SK19Y). This reduces the gain of the VOX control transistor providing the necessary antitrip threshold. ANTITRIP control VR5, adjusts the value of the antitrip voltage threshold so that the loud speaker output will not produce excessive positive DC output from the VOX rectifier so as to exceed the negative DC output from the antitrip rectifier and thereby cause the control transistor to actuate the relay. When speaking into the microphone normally, the positive voltage will exceed the negative antitrip voltage and actuate the relay. VR3 provides a coarse adjustment for relay sensitivity.

Relay hold time will be determined by DELAY control VR2, R22, C23.

The tone oscillator Q7 (2SC373) operates when the MODE switch is in CW position, and the key is closed. (Pin 10 grounded). It is a phase shift oscillator operating at approximately 800 Hz. The tone output is activated by the keying circuit and then coupled through SIDETONE LEVEL control VR4 to the receiver audio amplifier for sidetone monitoring in CW operation. The output from Q7 is also coupled to the VOX amplifier Q4 for semi break-in CW operation.

For Service Manuals Contact  
MAURITRON TECHNICAL SERVICES  
8 Cherry Tree Rd, Chinnor  
Oxon OX9 4QY  
Tel:- 01844-351694 Fax:- 01844-352554  
Email:- enquiries@mauritron.co.uk

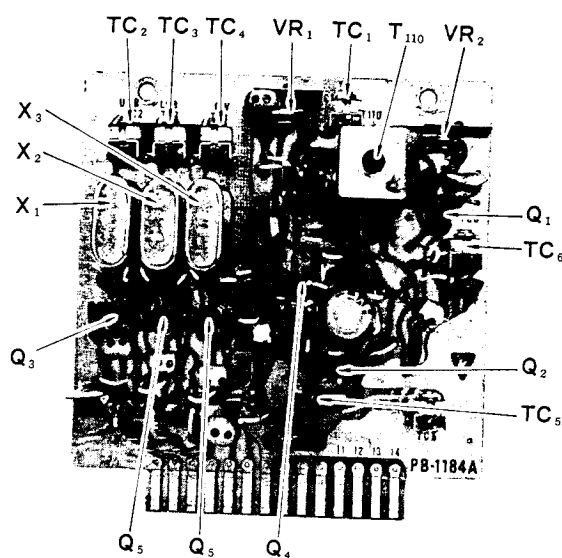

PB1184 A Fig. 1-15

MODULATOR UNIT (PB1184A)

The Modulator Unit contains the carrier oscillators, the ring modulator circuit for SSB, and AM modulator. The carrier oscillator oscillates either 3178.5 kHz for USB or 3181.5 kHz for LSB, depending upon whether Q3 (2SC372Y) or Q5 (2SC372Y) is selected by the MODE switch. The MODE switch opens the emitter circuit of the transistor that is not in use. The output from the selected oscillator is fed to the buffer amplifier Q4 (2SC828P) and then to the balanced ring modulator D1-D4. The RF carrier signal is also fed to the ring demodulator from pin 6 for receive. These crystal frequencies are matched to the bandpass of the crystal filter to place the carrier frequency approximately 25 db down on the skirt of the filter response.

For AM and CW operation, the 3179.3 kHz crystal controlled oscillator Q6 (2SC372Y) operates to produce the carrier signal and both Q3 and Q5 are disconnected. Q2 (2SC372Y) operates as a modulator for AM operation and as a buffer stage for CW operation. The speech signal is fed to the balanced ring modulator and AM modulator Q2 from pin 9.

Carrier balance is obtained by a potentiometer VR1 and a trimmer capacitor, TC1. The resulting double sideband suppressed carrier output from the balanced modulator is amplified through T110 by the IF amplifier Q1, (2SK19Y) and fed to the low frequency IF unit from pin 12. For AM and CW, the output signal from Q2 is fed directly to the high frequency IF unit, through CARRIER potentiometer VR2 on the front panel from pin 8.

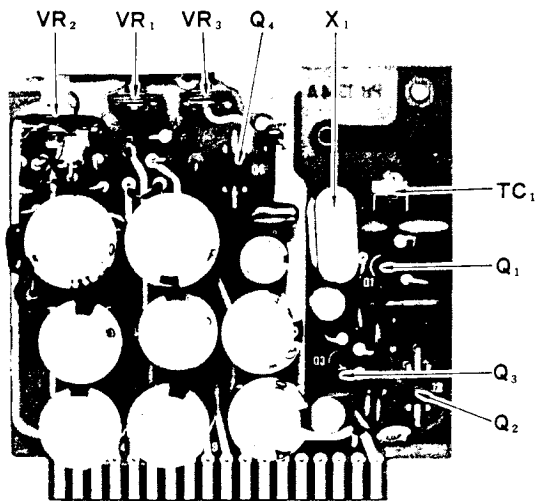

PB-1314A

Fig. 1-16

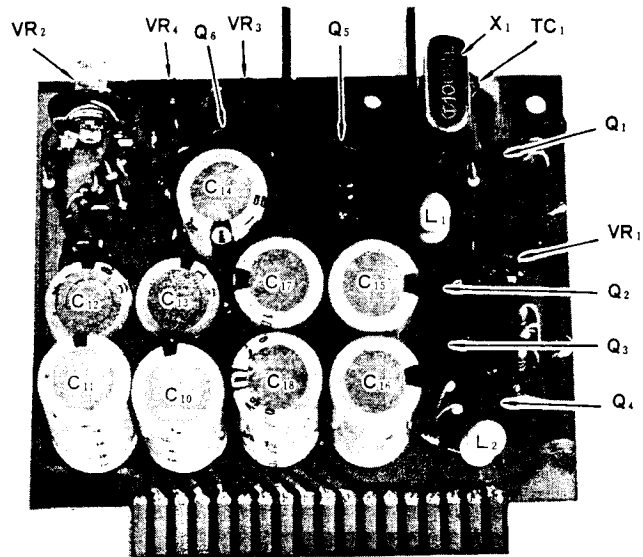

(PB-1079A)

Fig. 1-17

### POWER REGULATOR UNIT (PB1314A)

The DC 13.6 volts from the rectifier unit is supplied through pin 14 to the voltage regulator IC Q4, (MFC6034A) in this unit to obtain a stable 6 volt DC supply which is then fed to the various circuits from pin 13. The regulated voltage is also supplied to the CLARIFIER control, which is used to offset the receive frequency  $\pm 3$  kHz either side of the transmitted signal, when activated. VR4 permits adjustment of the voltage to vary the receive and transmit frequency so it will coincide at the CLARIFIER zero or OFF position. A -100 volt negative voltage is delivered to pin 5 of the unit from the rectifier board, PB1076B.

VR2 sets the operating bias at approximately -50 volts for the final amplifier tubes. This bias voltage is -60 volts on receive and supplies the grid circuit of the final tubes on the main chassis from pin 2. The bias for the driver tube 12BY7A is also supplied from pin 4. This voltage is -20 volts on receive and -3.5 volts for transmit. Notice that these are voltages, and not related to the IC reading. The meter, when set to IC reads cathode current, which in the idle position should read 60ma. With the FT-101 keyed in the SSB mode, adjust the bias current until 60ma is achieved.

This module also contains the 100 kHz/25 kHz marker generator. Crystal controlled oscillator Q1, (2SC735Y) oscillates at the 100 kHz crystal frequency and is used for dial calibration. Trimmer capacitor, TC1 is used to calibrate the internal 100 kHz against WWV or JJY. Output from the oscillator is fed into the 25 kHz multivibrator Q2, (MFC6020) which generates a marker signal every 25 kHz. The multivibrator operates whenever the supply voltage is applied to pin 17 from the switch on the front panel. The calibrator output is fed through the buffer amplifier Q3, (2SC735Y) to the receiver antenna circuit from pin 16. As noted elsewhere, this signal is also used for troubleshooting and analysis of receive problems.

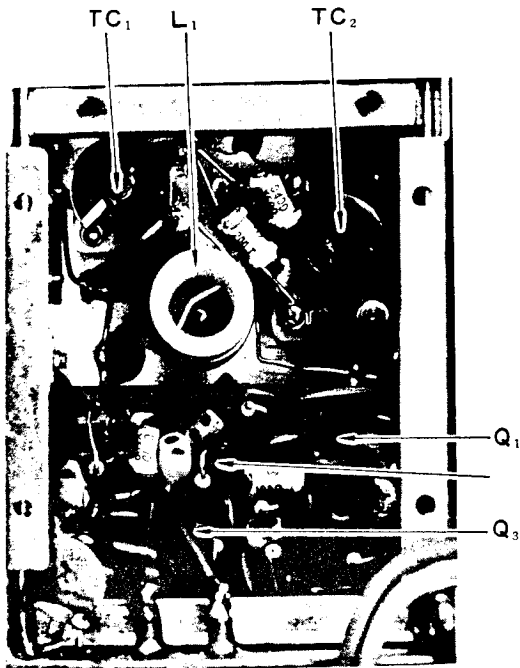

VFO UNIT

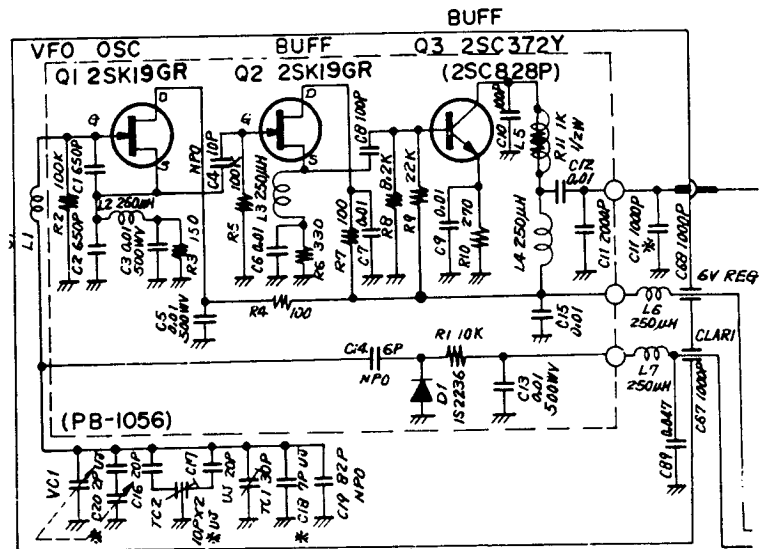
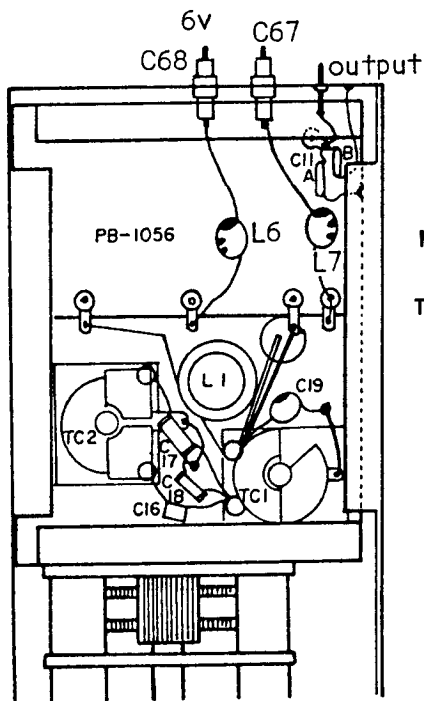

Fig. 1-18

VFO UNIT (PB1056)

The VFO module board is installed in the VFO chassis. The VFO uses FET transistors Q1 (2SK19GR) and Q2 (2SK19GR) first buffer Q3 (2SC372Y) buffer provides isolation and amplification of the VFO signal.

The VFO oscillation frequency is 8700 kHz to 9200 kHz providing a spread of 500 kHz. Varactor diode D1 (1S145) in series with capacitor C14 is switched into the circuit by the clarifier switch and the relay contacts, to shift the VFO frequency for receiver offset tuning. The offset does not affect the transmitter setting.



For Service Manuals Contact  
**MAURITRON TECHNICAL SERVICES**  
 8 Cherry Tree Rd, Chinnor  
 Oxon OX9 4QY  
 Tel:- 01844-351694 Fax: 01844-352554  
 Email: enquiries@mauritron.co.uk

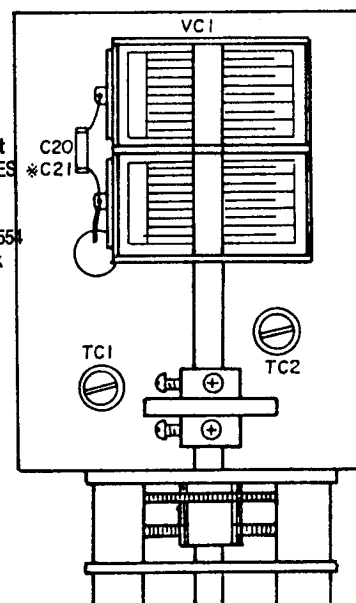

Fig. 1-19

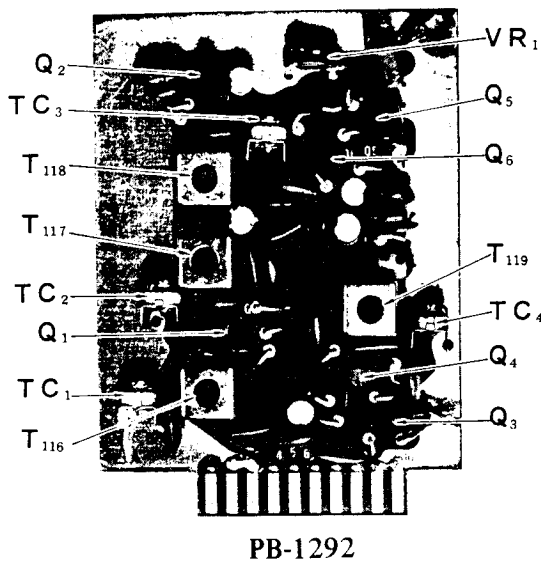

Fig. 1-21

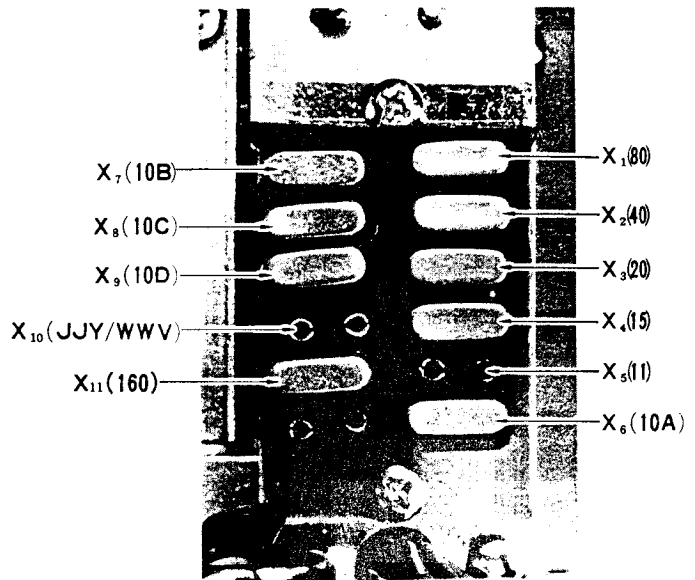

Fig. 1-22

### NOISE BLANKER UNIT (PB1292)

The 3180 kHz output signal from the receiver 2nd mixer is fed to the base of IF amplifier Q1 (2SC372Y) through pin 4 and T116. The signal is then fed to the gate of the IF amplifier Q2 (2SK19GR) through the noise blanker diode D1 (1S1555). It is then fed to the IF amplifier chain in the low frequency IF unit PB1183 through pin 1.

The above 3180 kHz signal is also fed to the gate of noise amplifier Q3 (2SK19GR) and amplified through Q3 and Q4 (2SC784R).

Pulse rectifier diode D3 (1S1555) conducts with the noise pulses in the output from Q4 and negative output voltage from the diode is applied to the gate of Q5 (2SK19GR) in order to turn off Q5. The noise blanker driver Q6 (2SC372Y) conducts to switch the noise blanker diode D1, which opens the input circuit of the IF amplifier Q2 whenever a narrow noise pulse exists.

The switching level of the diode D1 is set by the noise blanker threshold control VR1. At the most effective blanking position, there may be slight distortion on the received signal due to mixing at the switching diode. This effect can be reduced by adjusting the threshold control slightly.

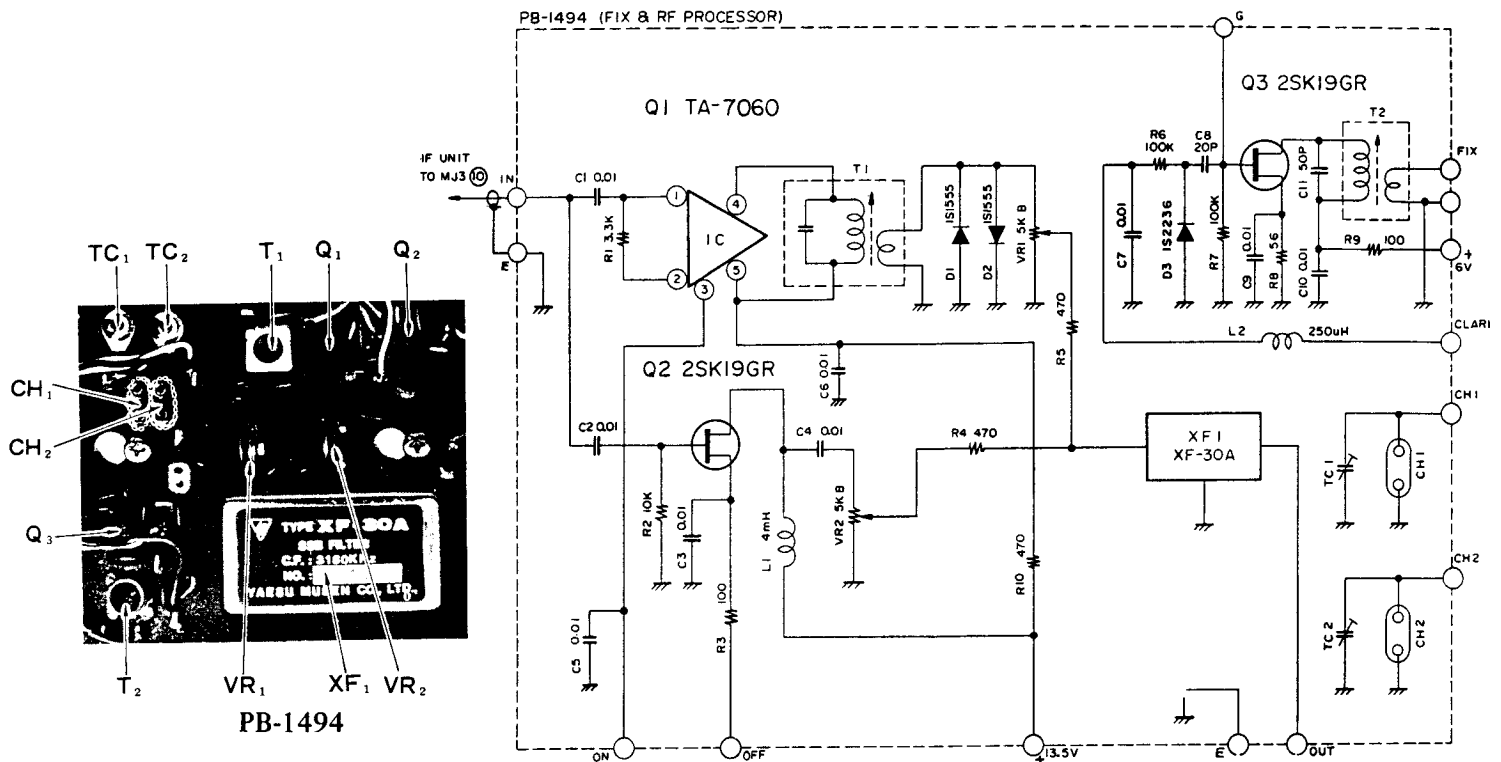

Fig. 1-23

RF PROCESSOR (PB1494)

The single sideband signal arriving from the crystal filter (XF32A) is fed to Q2, (2SK19GR) and Q1, IC (TA7060). When the processor switch is in the OFF position, the above signal is only amplified by Q2 to compensate for the loss which is caused by having an additional crystal filter, XF1 (XF30A) in the RF circuit.

With the processor switch ON, the signal is amplified and compressed through the compressor amplifier Q1, (TA7060). The compressed signal is delivered through T1 to diodes D1 and D2, (1S1555) where the peaks of the compressed RF signal are clipped.

The harmonics generated by the clipper diodes are completely removed by the following processor filter XF1, (XF30A) and the processed signal is then delivered through the diode switch to the mixer unit.

In addition to normal VFO operation, two crystals may be selected for crystal controlled operation by a selector switch located on the front panel of the transceiver.

The crystal holders accept standard HC-25/U type crystals. All crystal frequencies must fall between 8.700 kHz and 9.200 kHz. A trimmer capacitor has been connected in parallel with each crystal to permit proper frequency adjustment. Adjustment of this trimmer will change the crystal frequency approximately 1 kHz.

Some exceptions can be made to the 8.700 kHz to 9.200 kHz crystal limits that will allow MARS or CAP "out of band" operation. (See modification section)



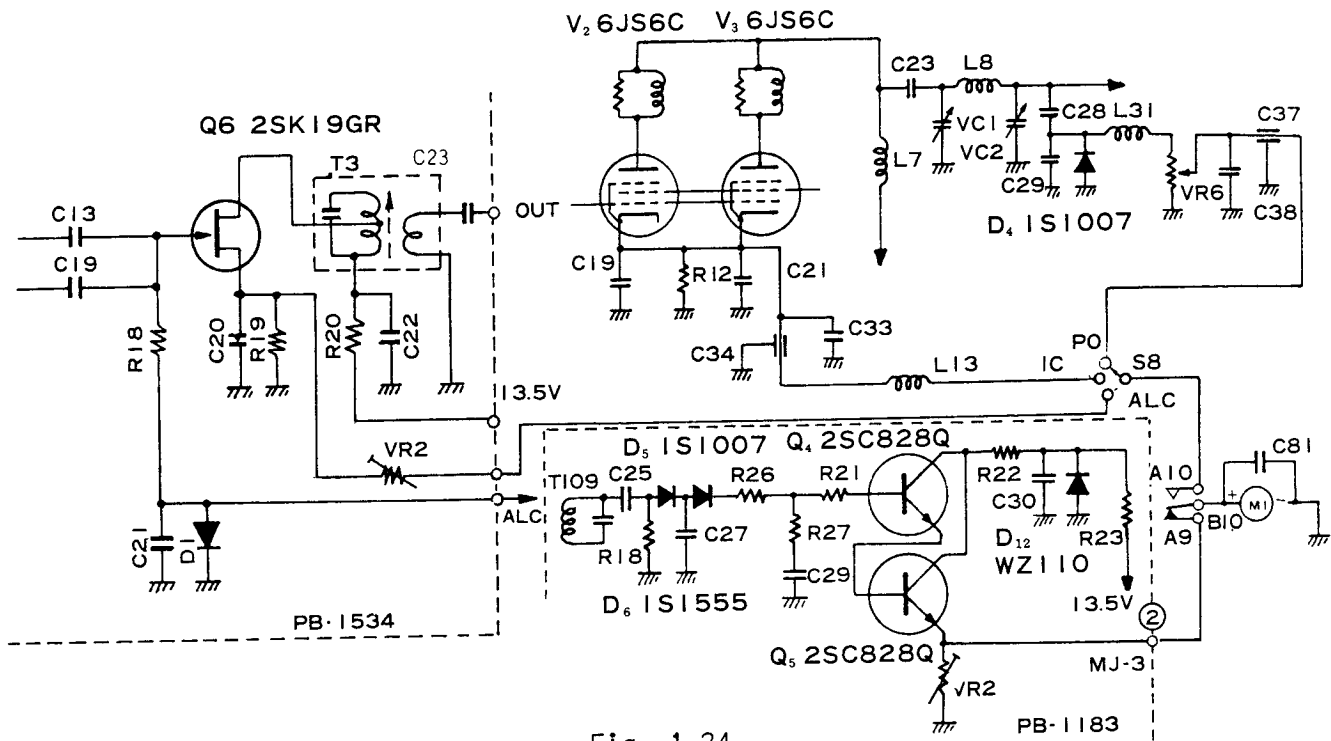

Fig. 1-24

### METERING

The meter circuit is wired to indicate signal strength, when receiving and, on transmit the meter may be switch selected to indicate cathode current, relative power output, or automatic level control (ALC). The meter functions are automatically switched by means of relay contacts between transmit and receive modes.

ALC meter readings are controlled by variations in grid current flowing in the final amplifier tubes. If the final amplifier is overdriven due to modulation, a portion of the grid current flow is then rectified and applied to the sink of Q1 (2SK19) on PB1184A. The meter then indicates the current flowing in the 2SK19 which is in turn representative of the ALC control voltage, arriving at pin 14 of PB1184A, from the low end of L12.

In the IC position, the meter is connected to the cathodes of the final tubes in parallel with shunt resistor R12, and is measuring the total cathode current of the tubes.

In the P0 position, the relative power output is indicated by the rectified DC current at the pi output circuit. The meter sensitivity is adjusted by potentiometer VR6 located on the rear panel.

When the transceiver is in the receive mode, the AGC voltage developed by the received signal is fed to the meter amplifiers Q4 and Q5 located on PB1183B, pin 2 to provide a meter deflection proportional to input signal strength. The meter is calibrated in the customary "S" units. A meter indication of S-9 represents approximately 50 microvolts at the antenna terminals, and can be adjusted to that value using a precision signal generator while adjusting VR2 located on PB1183B.

## PLUG-IN MODULE CIRCUITS

### BASIC CIRCUITS

The basic circuits used in the FT-101 are described in the following paragraphs to help understand the functional descriptions provided later in the manual.

### INHIBIT GATE

The signal normally passes through an INHIBIT gate; adding a second signal closes the gate and prevents the signal from going through. One of the most common forms of the INHIBIT gate is the series gate shown in Fig. 1-26. When the diode is biased off, the gate is closed, and signals cannot pass through. When the diode is biased on, the signals go through the diode and reach their destination. Visualize it as a remote controlled switch that we use to route signals into circuits, or to isolate signals from getting into circuits.

### LIMITER/CLIPPER

The limiter/clipper is a circuit that removes positive or negative peaks from waveforms. It can be used either as a waveform clamping circuit or as a protective device to prevent excessive voltages from reaching a sensitive circuit. Fig. 1-26 shows a limiter that prevents the negative peak of a pulse from going more negative than about -0.6 volt. Note that for a conducting silicon diode the cathode voltage is about 0.6 to 0.8 volt more negative than the anode.

### CLAMPER/DC RESTORER

The clamper or DC restorer is a circuit that establishes either the positive or negative peak of a waveform at a particular DC reference voltage; in other words, it provides a definite baseline voltage for the waveform. Fig. 1-26 shows a clamper that provides a baseline of about 20 volts for a negative pulse.

### REGULATORS

A diode regulator uses either the constant reverse bias breakdown voltage characteristic of a breakdown diode (Zener) or the constant forward bias voltage drop characteristic of a silicon diode. Power supply reference voltages are generally provided by breakdown diodes which maintain a constant voltage when supplied with a reverse bias voltage greater than their specified breakdown voltage. Regulated voltages can also be provided by a forward biased silicon diode which maintains a constant 0.6 to 0.8 volt drop. Fig. 1-26 shows connections for both types of diodes.

## NPN AND PNP TRANSISTORS

Transistors are used throughout the FT-101 in circuit configurations such as amplifiers, trigger circuits, and buffers. In the discussion, basic transistor operation and a few basic transistor circuits are briefly outlined. These paragraphs discuss the easily observed changes in currents and voltages in transistor circuits which help technicians locate circuit faults but do not attempt to describe how transistors work internally.

In a transistor a small base-to-emitter current controls a large collector-to-emitter current. A comparison of NPN transistor and PNP transistor operation is shown in Fig.1-27. Indicated current represents conventional flow of positive charges external to the transistor and is not intended to indicate flow of carriers inside the transistor structure. Notice that the effect of emitter-base-collector voltages is totally reversed between NPN and PNP transistors; circuits which are arranged for an NPN transistor usually function normally for a PNP transistor if supply voltages are reversed.

Three basic amplifier types are available (Fig.1-27). These amplifiers are used alone and in combinations to form complex circuits.

## FIELD EFFECT TRANSISTOR (FET)

Field effect transistors have three terminals; source, drain, and gate which correspond in function to emitter, collector, and base of junction transistors. Source and drain leads are attached to the same block (channel) of N or P semiconductor material. A band of oppositely doped material around the channel (between the source and drain leads) is connected to the gate lead.

In normal FET operation (see Fig.1-25) the gate source voltage, reverse biases the PN junction, causing an electric field that creates a depletion region in the source drain channel. In the depletion region the number of available current carriers is reduced as the reverse biasing voltage increases, making source drain current a function of gate source voltage. With the input (gate source) circuit reverse biased, the FET presents a high impedance to its signal sources (as compared with the low impedance of the forward biased junction transistor base emitter circuit). Because there is no input current, FET's have less noise than junction transistors. Fig.1-25 shows the schematic symbol and biasing for N channel and P channel field effect transistors.

For Service Manuals Contact  
**MAURITRON TECHNICAL SERVICES**  
8 Cherry Tree Rd, Chinnor  
Oxon OX9 4QY  
Tel: 01844-351694 Fax: 01844-352554  
Email: enquiries@mauritron.co.uk

COMMON SOURCE

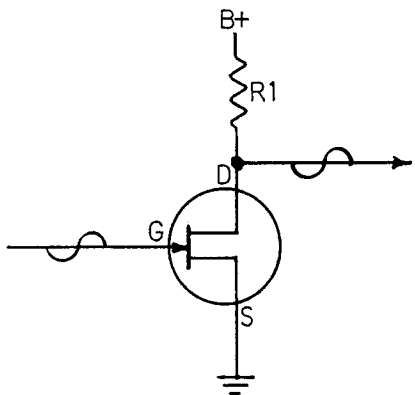

INPUT IMPEDANCE=1M to 15M $\Omega$   
 OUTPUT IMPEDANCE=50K to 100K $\Omega$   
 VOLTAGE GAIN=10 to 200  
 POWER GAIN=60 to 100dB

COMMON DRAIN/SOURCE FOLLOWER

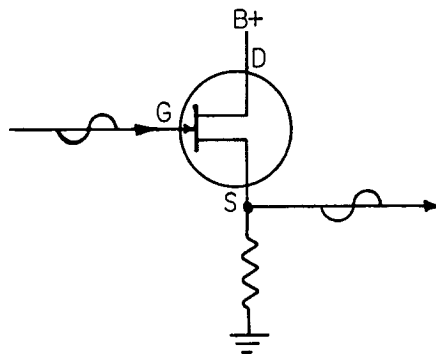

INPUT IMPEDANCE=1M to 15M $\Omega$   
 OUTPUT IMPEDANCE=1K to 10K $\Omega$   
 VOLTAGE GAIN= 1  
 POWER GAIN=40 to 80 dB

FET AMPLIFIER CHARACTERISTICS

FET OPERATION

Fig. 1-25

FET BIASING

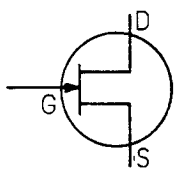

N CHANNEL

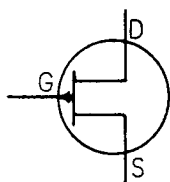

P CHANNEL

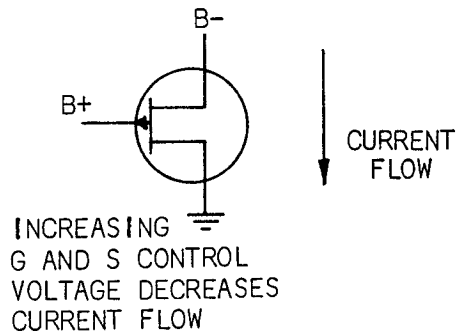
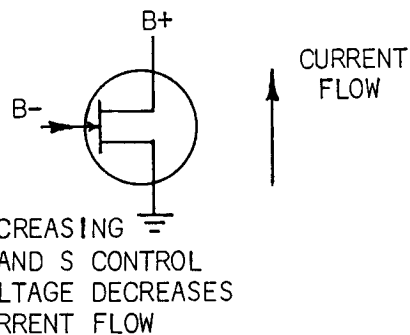
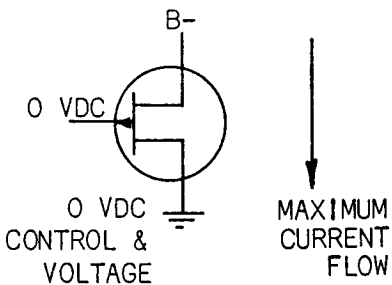
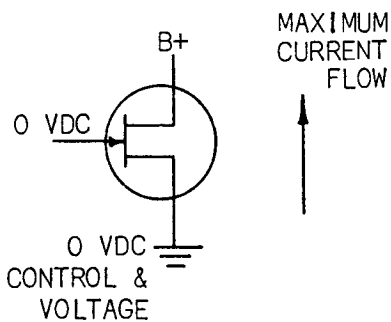

# BASIC DIODE CIRCUITS

## INHIBIT GATE

Fig. 1-26

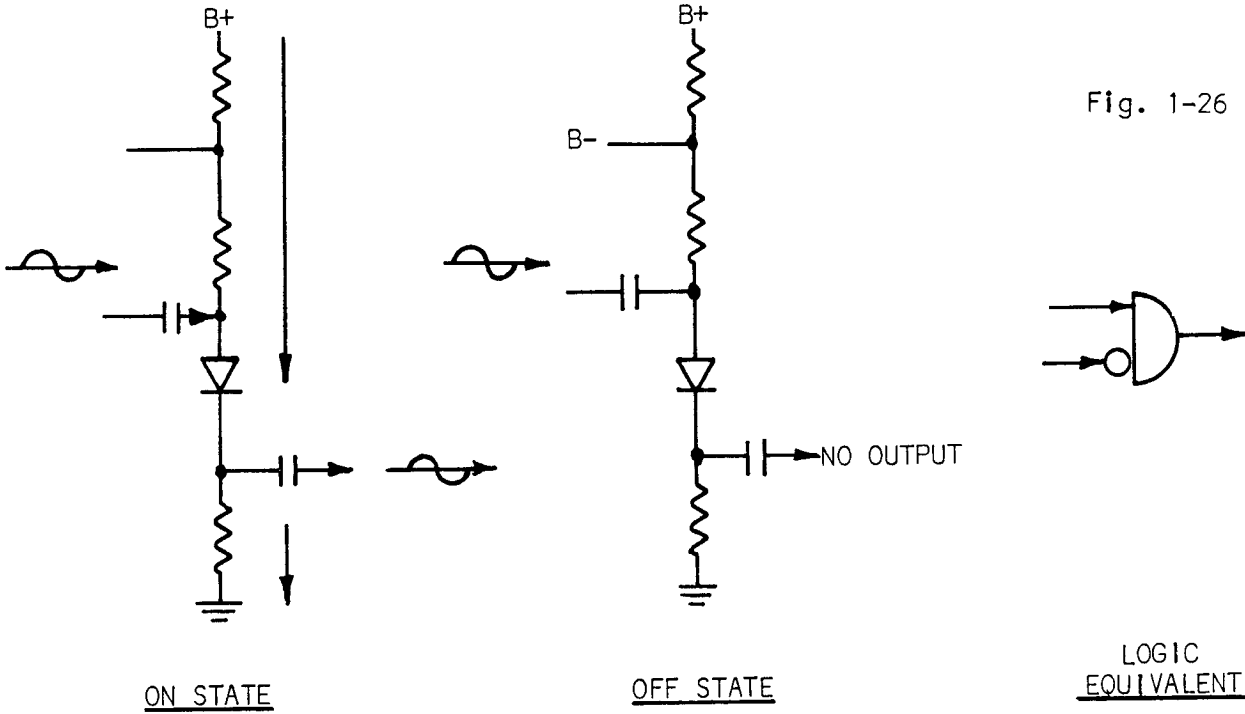

ON STATE

OFF STATE

LOGIC EQUIVALENT

## LIMITER

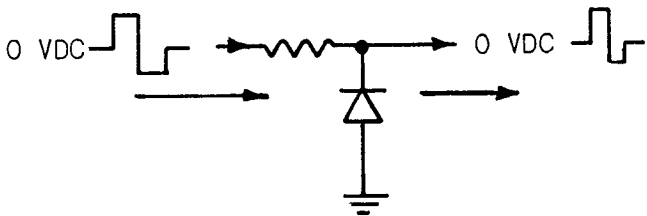

## CLAMPER

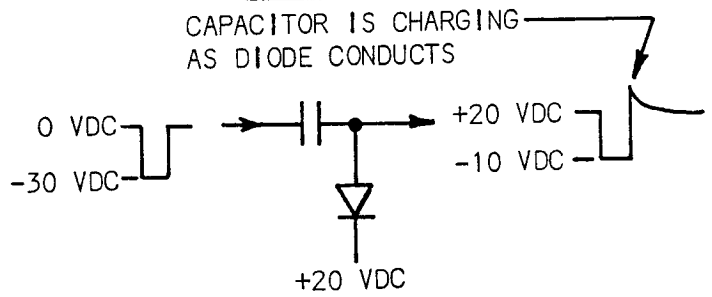

## REGULATORS

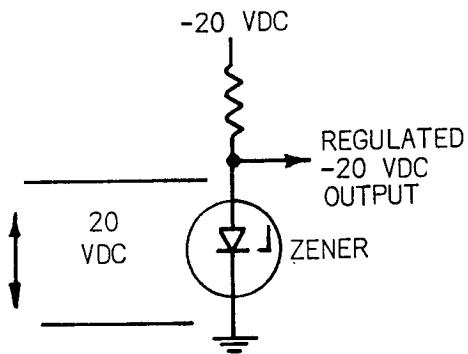
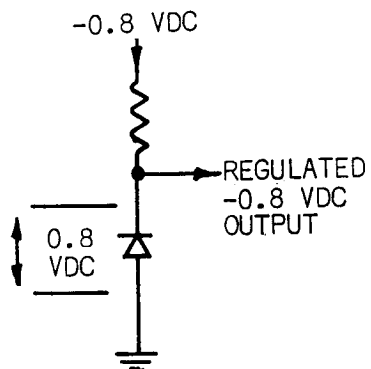

COMMON BASE

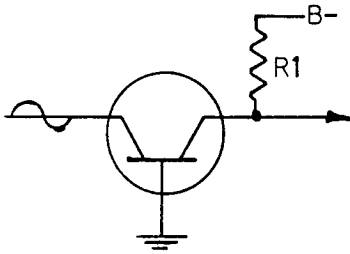

INPUT IMPEDANCE=30 to 50  
OUTPUT IMPEDANCE=300K to 500K  
VOLTAGE GAIN=500 to 1500  
CURRENT GAIN= 1  
POWER GAIN=20 to 30dB

COMMON COLLECTOR

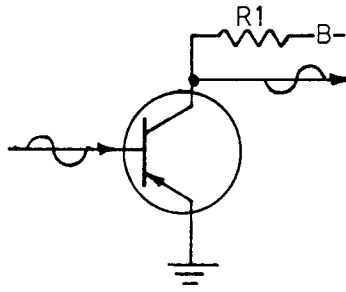

INPUT IMPEDANCE=500 to 1500  
OUTPUT IMPEDANCE=30K to 50K  
VOLTAGE GAIN=300 to 1000  
CURRENT GAIN=25 to 50  
POWER GAIN=25 to 40dB

COMMON EMITTER

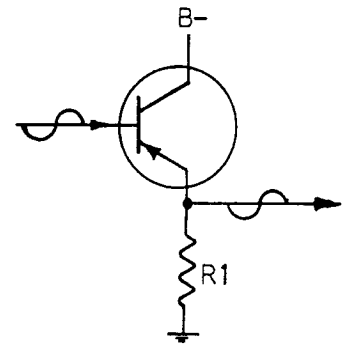

INPUT IMPEDANCE=20K to 500K  
OUTPUT IMPEDANCE=50 to 1K  
VOLTAGE GAIN= 1  
CURRENT GAIN=25 to 50  
POWER GAIN=10 to 20dB

TRANSISTOR AMPLIFIER CHARACTERISTICS

BASIC TRANSISTOR OPERATION

Fig. 1-27

TRANSISTOR BIASING

TYPE

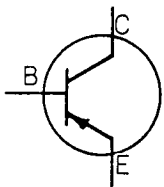

PNP

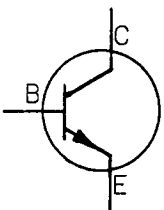

NPN

CUT OFF

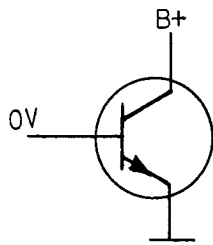
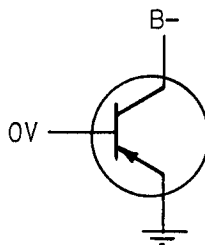

CONDUCTING

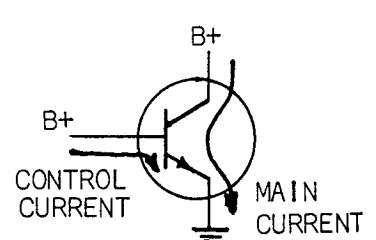
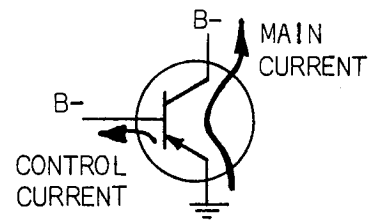

For Service Manuals Contact  
MAURITRON TECHNICAL SERVICES  
8 Cherry Tree Rd, Chinnor  
Oxon OX9 4QY  
Tel:- 01844-351694 Fax:- 01844-352554  
Email:- enquiries@mauritron.co.uk

## RECOMMENDED ACCESSORIES

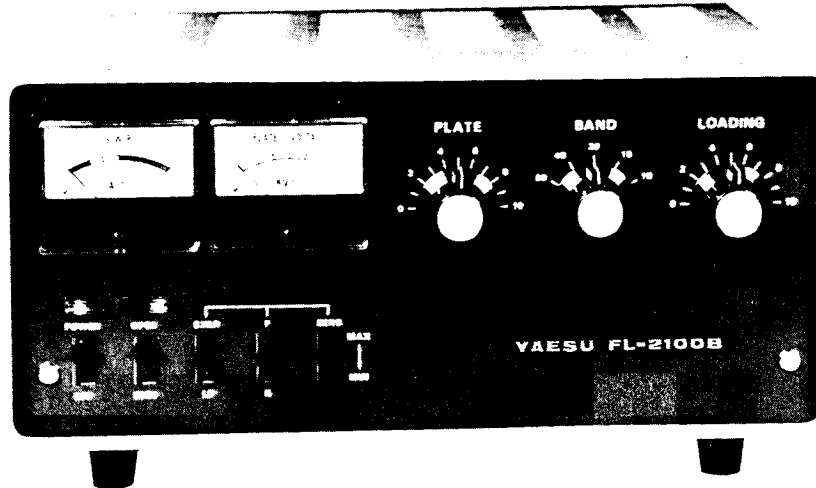

FL-2100B LINEAR AMPLIFIER

Fig. 1-28

The FL-2100B is a conservatively rated matching amplifier for the FT-101 series. This amplifier features two rugged 572B carbon plate tubes in a class B grounded grid circuit with individually tuned input coils for each band. The FL-2100B operates on 80 through 10 meters with dual cooling fan and a solid state power supply with an effective 28 uF filter system, providing reserve ratings and linear operation. Dual interlocks offer safety and shock protection. An automatic changeover circuit biases the tubes to cut-off on receive to maximize tube life and minimize heat. Bifilar wound, ferrite filament chokes guarantee minimum RF transfer to the power source. The FL-2100B offers maximum performance in one compact package.

### FEATURES

Conservative, 1200 watts PEP input on 80 - 10 meters. Easy primary voltage change from 117 - 234 VAC. Dual front panel meters provide continuous monitoring of plate current and voltage.

## FL-2100B SPECIFICATIONS

Frequency Range: 3.5 to 4.0 MHz; 7.0 to 7.5 MHz; 14.0 to 14.5 MHz;  
21.0 to 21.5 MHz, and 28.0 to 29.9 MHz.  
Plate Input Power: 1200 watts PEP on SSB, 800 watts on CW at 50% duty  
cycle and 600 watts on AM and RTTY.  
Drive Requirement: 30 to 100 watts.  
Input Impedance: 50 ohm unbalanced.  
Output Impedance: Nominally 50 ohm unbalanced with not more than 2.1 SWR.  
Distortion Products: -30 dB at 1200 watts input.  
Noise Level: 40 dB below single tone carrier.  
Circuitry: A pair of 572B in ground grid circuit.  
Power Requirement: 100/110/117 VAC at 18 amps.  
200/220/234 VAC, 50/60 Hz at 9 amps.  
Size: 340 (W) x 153 (H) x 285 (D) m/m  
Weight: 18.5 Kg.

For Service Manuals Contact  
MAURITRON TECHNICAL SERVICES  
8 Cherry Tree Rd, Chinnor  
Oxon OX9 4QY  
Tel:- 01844-351694 Fax:- 01844-352554  
Email:- enquiries@mauritron.co.uk



FV-101B EXTERNAL VFO

Fig. 1-29

Match up the FV-101B with your FT-101B/E/EE/EX and open up a new world of operating flexibility. DX'rs will particularly appreciate this combination. The FV-101B features the same factory sealed, solid state VFO with 1 kHz readout that is found in the FT-101E. A dual VFO adaptor is built in to the FT-101E/EE/EX, to accept a simple, plug-in cable. The FV-101B includes a fixed channel oscillator for up to four crystal controlled channels on any band - 160 through 10 meters.

## SPECIFICATIONS

Frequency Range: 8.7 to 9.2 MHz  
Frequency Stability: Within 100 Hz in any 30 minute period after warmup.  
Power Source: FT-101E  
Size: 210 (W) x 153 (H) x 285 (D) m/m  
Weight: 3.5 Kg.



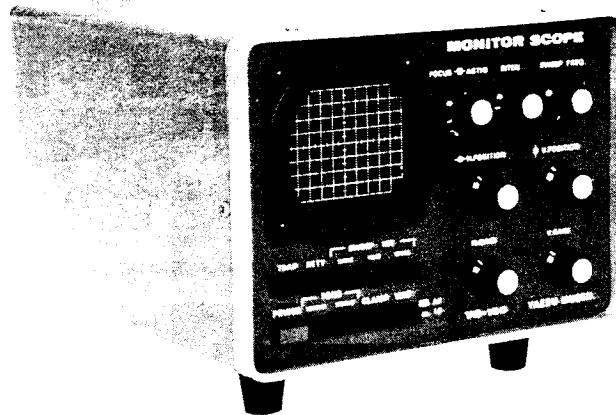

Fig. 1-30

### YO-100 MONITOR SCOPE

Now, you too, can maintain the cleanest sounding signal on the band with the YO-100 Monitor Scope. Compatible with virtually all transmitters and transceivers, the YO-100 features wide range inputs for all mode monitoring, even RTTY. A built-in 1500/1900 Hz tone generator adds to the versatility of this station accessory. A full compliment of front panel controls allows operator control of all key adjustments. Complete your station with the YO-100.

#### SPECIFICATIONS (Vertical)

Sensitivity: 200 mV P-P/cm

Frequency Response: 10 Hz to 40 kHz  $\pm 3$ dB 3180 kHz (455 kHz or 9 MHz inputs optional). Direct 10 Hz to 60 mHz.

Input Impedance: 500 K ohm

#### (Horizontal)

Sensitivity: 300 mV/cm

Frequency Response: 10 Hz to 16 kHz  $\pm 3$ dB.

Input Impedance: 500 K ohm

Sweep Frequency: 10 Hz to 10 kHz

#### (Two-Tone Generator)

Frequency: 1500 Hz and 1900 Hz

Output Level: 50 mV

Power Requirements: 100/110/117/200/220/234 VAC 50/60 Hz

Size: 210 (W) x 150 (H) x 290 (D) m/m

Weight: 6 Kg.

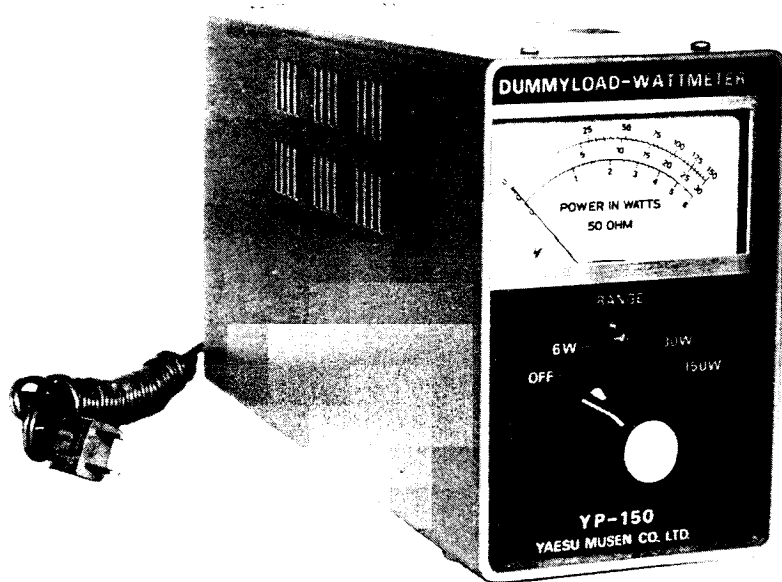

Fig. 1-31

YP-150 DUMMY LOAD/WATT METER

The model YP-150 can be used as dummy load and power meter within the frequency range of 1.8 MHz to 200 MHz. Three switch selected scales assure accurate power measurement in high and low power range. Built-in fan cools unit for stable measurement.

SPECIFICATIONS

Frequency Range: 1.8 MHz to 200 MHz  
Impedance: 50 ohm unbalanced  
Power Scale: 0 - 6 watts, 0 - 30 watts, 0 - 150 watts.  
VSWR: Less than 1.2 at 145 MHz  
Maximum Error: Within 10% of maximum scale  
Size: 104 (W) x 153 (H) x 280 (D) m/m.  
Weight: 2 Kg.

For Service Manuals Contact  
**MAURITRON TECHNICAL SERVICES**  
8 Cherry Tree Rd, Chinnor  
Oxon OX9 4QY  
Tel:- 01844-351694 Fax:- 01844-352554  
Email:- enquiries@mauritron.co.uk

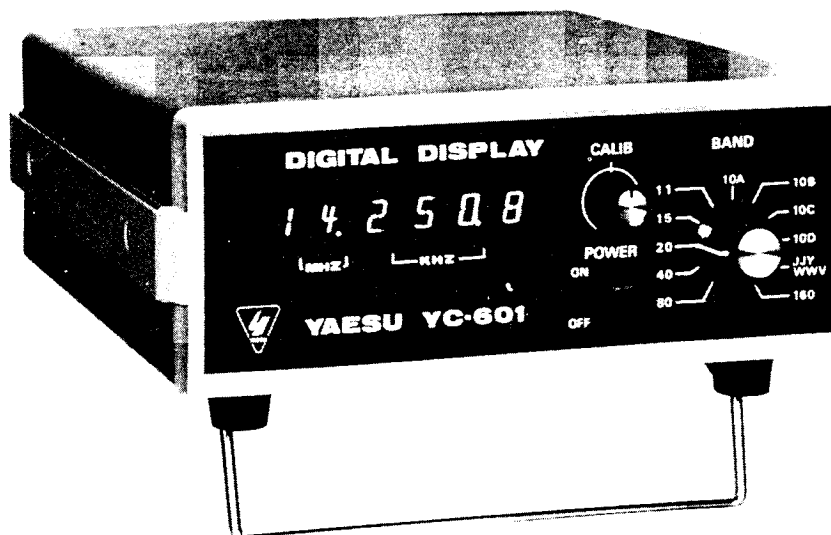

Fig. 1-32

### YC-601 DIGITAL DISPLAY

The model YC-601 displays actual transmit and receive frequencies on six bright, green colored digital display tubes.

All amateur bands are switch selected for complete frequency readout with 100 Hz accuracy.

The power supply is built in. Connection cable is supplied with the unit.

### SPECIFICATIONS

Display: 6 digits, 100 Hz readout

Clock Oscillator: 1.31072 MHz

Gate Time: 0.1 sec.

Ambient Temperature: 0° C - 40° C

Power Source: 100/110/117/200/220/234 VAC 50/60 Hz

Power Consumption: Approximately 10 VA

Size: 220 (W) x 80 (H) x 235 (D) m/m

Weight: 2.5 Kg.

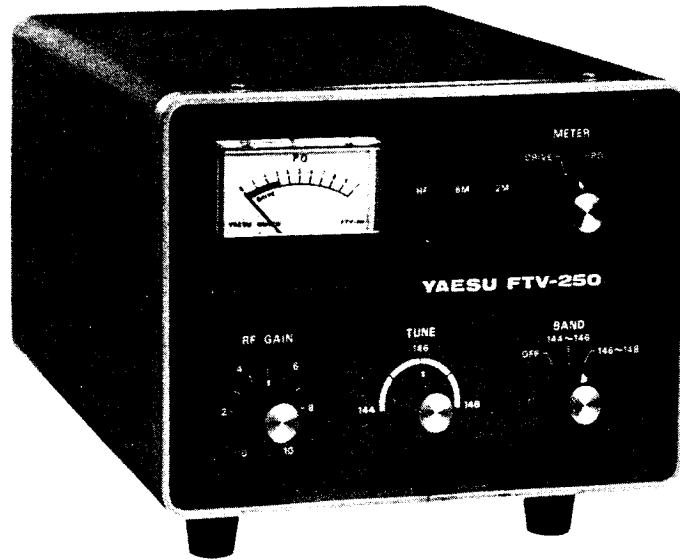

Fig. 1-33

FTV-250 2 METER TRANSVERTER

SPECIFICATIONS: (General)

Frequency Range: 144 to 148 mHz  
Mode: SSB, AM, CW and FM  
Size: 210 (W) x 153 (H) x 285 (D) m/m  
Weight: 6 Kg.

(Receiver)

Sensitivity: 0.5  $\mu$ V for 20 dB noise plus signal to noise ratio when used with our transceiver.  
Input Impedance: 50 to 75 ohms.  
Input Frequency: 28 to 30 mHz.  
Harmonic and Other Spurious Response: Image rejection better than 50 dB.  
Internal spurious signal below 1 $\mu$ V equivalent to antenna input.

(Transmitter)

Input Power: 10 watts PEP on SSB, 10 watts on CW at 50% duty cycle,  
4 watts on AM and FM.  
Drive Requirement: 3V RMS at 28 to 30 mHz (10 watts)



Fig. 1-34

FTV-650B 6 METER TRANSVERTER

SPECIFICATIONS: (General)

Frequency Range: 50 - 54 mHz  
 Mode: SSB, AM, CW and FM  
 Size: 210 (W) x 153 (H) x 285 (D) m/m  
 Weight: 4 Kg.

For Service Manuals Contact  
**MAURITRON TECHNICAL SERVICES**  
 8 Cherry Tree Rd, Chinnor  
 Oxon OX9 4QY  
 Tel:- 01844-351694 Fax:- 01844-352554  
 Email:- enquiries@mauritron.co.uk

(Receiver)

Sensitivity: 0.5  $\mu$ V for 10 dB noise plus signal to noise ratio when used with our transceiver.  
 Input Impedance: 50 to 75 ohms  
 Input Frequency: 28 to 30 mHz.  
 Harmonic and other Spurious Response: Image rejection better than 50 dB.  
 Internal Spurious signal below 1  $\mu$ V equivalent to antenna input.

(Transmitter)

Input Power: 50 watts PEP on SSB, 50 watts on CW at 50% duty cycle, 10 watts on AM and FM.  
 Drive Requirement: 3V RMS at 28 to 30 mHz (10 watts)

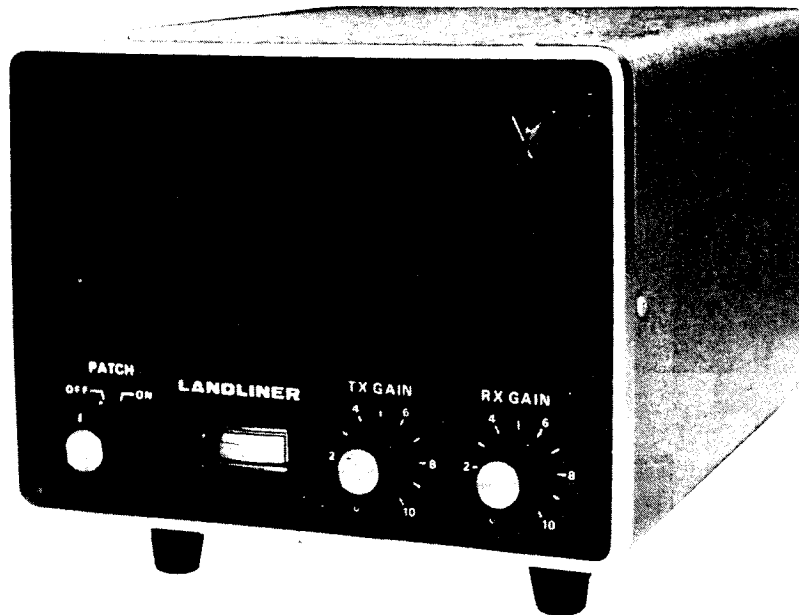

Fig. 1-35

SP-101PB SPEAKER/PHONE PATCH CONSOLE

To compliment your station, add the SP-101PB speaker/phone patch console. It features a shaped response speaker from 300 to 3000 Hz - ideal for quality communications reproduction. Built into this matched unit is a hybrid phone patch with individual gain controls for receiver-to-line and line-to-transmitter levels. A VU meter monitors the phone line audio level. Full VOX phone patch operation is possible with SP-101PB. Add this exciting accessory to your station today.

SPECIFICATIONS:

Receiver Input Impedance: 4 or 600 ohm.  
Output Impedance: 600 ohm or high impedance.  
Size: 210 (W) x 153 (H) x 285 (D) m/m.  
Weight: 3 Kg.

## OPTIONAL ACCESSORIES

### XF-30C 600 Hz CW FILTER

An optional CW filter providing 600 Hz at 6 dB/1.2 kHz at 60 dB skirt selectivity for enjoyable CW operation. The XF-30C is easily installed in minutes.

### MMB-1 MOBILE MOUNTING BRACKET

The MMB-1 is a floor type mount designed for an "over the hump" installation. It mounts directly to floor and enables the transceiver to be positioned at an optimum angle for easy viewing and operation.

### RFP-102 RF SPEECH PROCESSOR FOR FT-101EE/EX

Completely assembled, with full installation instructions.

### FA-9 COOLING FAN

The FA-9 is a low noise, muffin type fan which easily mounts on the rear panel of the FT-101 series. Operating voltage is supplied through a plug-in connector and the fan functions in both mobile and base installations.

### SP-101B SPEAKER CONSOLE

Same as the SP-101PB but without hybrid phone patch.

### YD-844 DYNAMIC BASE MICROPHONE

Available in high or low impedances.

# OPERATING INFORMATION

## SECTION 2

CONTENTS	PAGE
CONTROLS AND SWITCHES . . . . .	2-1
REAR APRON CONNECTIONS . . . . .	2-4
FREQUENCY SELECTION . . . . .	2-6
NORMAL TUNE UP . . . . .	2-7
ANTENNAS . . . . .	2-8

**For Service Manuals Contact**  
**MAURITRON TECHNICAL SERVICES**  
8 Cherry Tree Rd, Chinnor  
Oxon OX9 4QY  
**Tel:- 01844-351694 Fax:- 01844-352554**  
**Email:- enquiries@mauritron.co.uk**

### ANTENNAS

The FT-101 series of transceivers are designed to operate into a 50 to 75 ohm resistive load, and will perform well with any of the common antennas designed for use on the amateur HF bands.

NEVER TRANSMIT WITHOUT HAVING EITHER A DUMMY LOAD OR THE PROPER ANTENNA CONNECTED TO THE TRANSCEIVER.

If antennas and feedline theory are not well understood by the owner, it is suggested that the user get a copy of one of the ARRL publications (Electronics Data Book, Amateur Handbook, Antenna Book, etc.) and spend some time making his antenna system as efficient as possible.



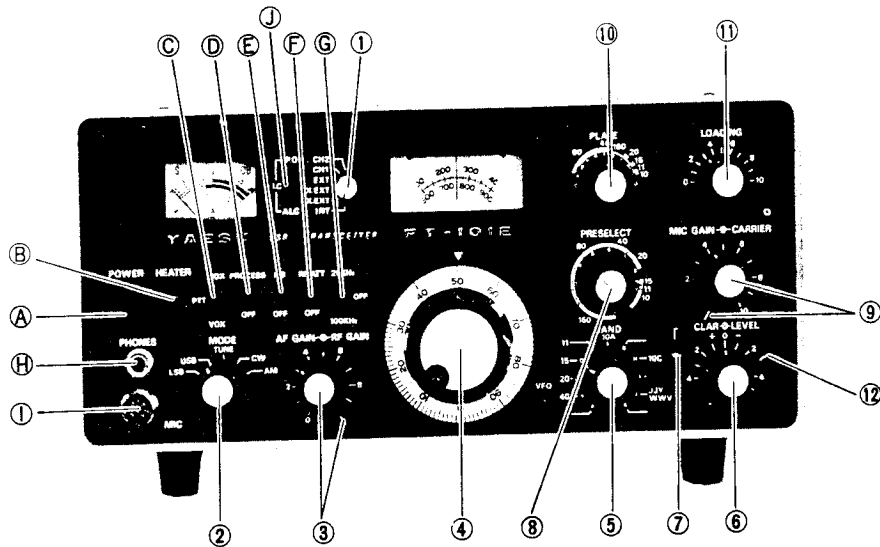

Fig. 2-1

### CONTROLS AND SWITCHES

The various front panel controls and their functions are described in the following section. Be certain that you understand thoroughly the function of each control before assuming that the transceiver is malfunctioning. Frequently a new (inexperienced) owner does not take time to read the manual, and more or less "makes" the unit fail.

1. VFO SELECT SWITCH: This switch provides optional selection of the companion FV-101B external VFO, two fixed crystal oscillator positions, or Normal operation of the transceiver using its internal VFO. The switch should be placed in the "INT" position for normal internal VFO use.

INT --- INTERNAL VFO controls both transmitter and receiver frequencies.

RX EXT--EXTERNAL VFO controls the receiver frequency and the FT-101 VFO controls transmitter output frequency.

TX EXT--EXTERNAL VFO controls the transmitter output frequency and the FT-101 VFO controls the receiver frequency.

EXT --- EXTERNAL VFO controls both transmitter and receiver frequencies.

CH1/CH2--Provides crystal control of the transceiver on either of two "spot" frequencies within a band. Proper crystals must be installed on PB1494 crystal oscillator board for crystal controlled operation.

CAUTION:The crystal will be active on all bands.

2. MODE SWITCH: (LSB, USB, TUNE, CW, AM) The MODE switch is a five-position switch. This switch is used to select the mode of operation; LSB, USB, AM, CW, or TUNE position. In the AM, CW and TUNE position, a separate crystal is used to shift the carrier frequency into the filter passband, but it's level (strength) is set with control (9).

3. RF GAIN/AF GAIN: The RF GAIN and AF GAIN controls are mounted on concentric shafts. RF GAIN control (lever control) manually varies the gain of the receiver RF and IF amplifiers. Maximum sensitivity is obtained with the control set at 10 (full clockwise).

The AF GAIN control (round knob) adjusts the audio output level at the speaker and phone jack. Clockwise rotation increases the audio output.

4. TUNING KNOB: The tuning knob located directly below the main dial window (in combination with the band switch) identifies the actual frequency of operation when the clarifier (7) is off.

The VFO drive mechanism consists of a precision spring loaded split gear system in combination with a planetary drive unit to provide zero backlash at low tuning rates. Each revolution of the tuning knob results in a frequency change of 16 KHz as indicated on the skirt surrounding the tuning knob.

5. BAND SWITCH: The band switch is an eleven-position switch used to select the desired band for receiving or transmitting. The band indication is color coded to help guide the operator in selecting the proper frequency scale for each band.

6, 6A, 7. CLARIFIER/LEVEL CONTROL: The clarifier control provides a means for tuning the receiver frequency 3 KHz to either side of the transmitting frequency. Thus, it is possible to set the pitch of the voice you are receiving to the most readable point without affecting your transmitting frequency. Its use is particularly valuable in "net" operation where several participants may be transmitting slightly off frequency. The clarifier control functions with the clarifier switch (7) set to the push-down position, and a red warning lamp lights up. With the clarifier switch in the out position, the red lamp turns off and the receiver is again locked to the transmitting frequency.

The lever control allows adjustment of the RF speech processor (D). Normally, you will want to keep the clarifier in the OFF position until the initial contact is made. The clarifier control may then be used to zero-in and correct any drift on the received signal.

8. PRESELECT: This control tunes the signal circuits for both transmit and receive. The preselect circuit provides continuous permeability tuning throughout the frequency range of the transceiver.

9. MIC GAIN/CARRIER: The MIC GAIN/CARRIER controls are mounted on concentric shafts. The carrier control (lever control) varies the amount of the carrier in the CW, AM and TUNE modes of operation.

The MIC GAIN control (round knob) varies the audio level from the microphone amplifier stage. The control has sufficient range to permit the use of any high impedance crystal or dynamic microphone. Both controls have maximum gain with the control set at 10 (full clockwise).

10. PLATE: Tunes the transmitter plate circuit of the final amplifier to resonance at the desired output frequency.

11. LOADING: Tunes the output leg of the pi network to match antenna and feed line impedance.

(A) POWER: Main switch turns transceiver "ON" for both AC and DC operation.

(B) HEATER: With this switch in the down position, the transmitter tube heaters are turned off. This reduces current drain to 0.5 amp when mobile and thus permits long periods of listening without excessive battery drain. Pushing the rocker switch to the upper position provides supply voltage to the tube heaters. After a 30 second warm-up, the transmitter is ready for operation. This switch operates in both DC and AC modes.

(C) MOX-PTT-VOX (FUNCTION SWITCH): This switch selects desired transmitter mode for both microphone and key operation.

MOX - (Manual transmit switch position) Locks transmitter "ON" and must be returned to PTT position for receiver recovery.

PTT - (Push-to-talk) Locks transmitter "ON" when microphone switch is depressed. Receiver recovers automatically when microphone switch is released.

VOX - (Voice operated transmit or semi break-in CW operation) This switch position allows the operator to actuate the transmitter by simply speaking into the microphone. Receiver recovers automatically when the operator stops speaking.

For semi break-in CW, the VOX system will actuate the transmitter each time the key is depressed, and receiver recovers each time the key is released.

(D) PROCESS: An RF speech processor is activated to increase the modulation power. With this switch in the "ON" position, lever control (6A) provides level setting for best efficiency on each band.

First used on FT-101E, but late FT-101's, B, EE and EX can be retrofitted to use a processor.

(E) NB (NOISE BLANKER): In upper position, the noise blanker is placed in the circuit and eliminates noise pulses typically caused by auto ignition.

(F) RF ATT (RF ATTENUATOR): This switch provides insertion of a 20 dB attenuator in the incoming signal path to minimize cross modulation which may be caused by extremely strong local signals.

(G) 25 kHz/100 kHz (CALIBRATOR): The 100 kHz crystal oscillator is used to calibrate the receiver. In the 25 kHz position, the 25 kHz multivibrator generates a marker signal at each 25 kHz point on the dial. Clarifier control must be in the "OFF" position when setting calibration.

(H) PHONES: Headphones may be inserted in this jack for private listening. The internal speaker is disconnected when the headphone plug is inserted. Any high quality low impedance head phone may be used.

(I) MIC: Microphone Jack - A four pin connector is used for microphone input, and push-to-talk relay actuation.

(J) METER: Selects the meter mode to read PA cathode current (I.C.), relative power output (PO), or ALC feedback voltage. Lower meter scale is calibrated 0 - 500 ma. (Example: .25 = .250 ma)

### REAR APRON CONNECTIONS AND CONTROL

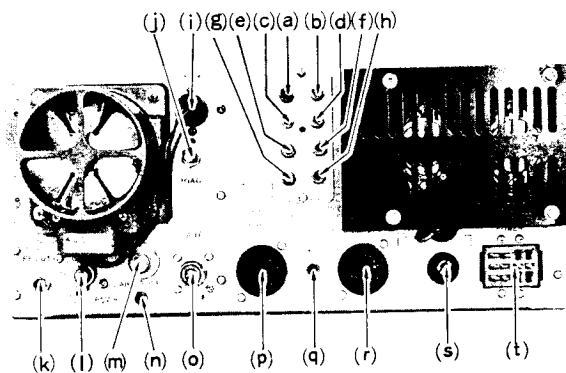

For Service Manuals Contact  
**MAURITRON TECHNICAL SERVICES**  
 8 Cherry Tree Rd, Chinnor  
 Oxon OX9 4QY  
 Tel:- 01844-351694 Fax:- 01844-352554  
 Email:- enquiries@mauritron.co.uk

Fig. 2-2

### REAR APRON CONNECTIONS

a. AF-IN: Audio input jack for auxiliary station equipment. An FM detector unit, or a high impedance microphone, may be applied at this point for audio output from the transceiver speaker, for mobile PA paging.

b. IF OUT: 3180 kHz IF signal is available from this jack for use with other station equipment such as panoramic adapter, YO-100, etc.

- c. SP: Audio output is provided at this jack for an external speaker. Output impedance is 4 ohms and the internal speaker will be disabled when plug is inserted.
- d. PTT: This jack may be used for external actuation of the transmitter. For example, a foot switch may be inserted into this jack to provide hands free control of the transmitter PTT relay.
- e. PATCH: Speech input terminal for phone patch connection. Impedance is 50K ohms. Can also accept AFSK tone inputs for RTTY facsimile or Slo-Scan.
- f. REC: This jack is connected to the receiver output (4 ohms) to be used for phone patch or other use. Also, it can be used to supply input to ATV or RTTY converters.
- g. TONE: Sidetone output for external monitor receiver if used.
- h. A-TRIP: Anti-trip input from external receiver if used.
- i. FAN: Power outlet for optional cooling fan.
- j. P.O. ADJUSTMENT: Meter sensitivity adjustment for relative power output indication.
- k. RF OUT: Signal frequency output from the driver stage may be obtained at this jack for use of optional equipment, such as the FTV-250, FTV-650B transverters, or the YC-355D counter, etc.
- l. GND: Ground connection. For safety and best efficiency, provide a good earth ground for your FT-101.
- m. LAMP FUSE: This lamp fuse protects the RF amplifier transistor from damage which may be caused by extremely strong local signals. Not installed in early FT-101's, but can be added (see modification section).
- n. RCV ANT: Another receiver can be connected through this jack.
- o. ANT: Coaxial connection for antenna.
- p. ACC: Accessory socket. Provides easy access to transceiver operating voltages and relay contacts at this outlet. NOTE: The accessory plug with pins 1 and 2 shorted together must be in place, or final heaters will not light.
- q. KEY: Key jack for code operation.
- r. EXT VFO: Connections for external VFO, FV-101B, or YC-601 digital display.
- s. FUSE: Fuse holder requires 5 amp fuse for 117 volt or 3 amp fuse for 220 volt operation. DC power cord fuse 20 amp.

## FREQUENCY SELECTION

Band selection is accomplished by switching the eleven (11) position band switch (item 5 of Fig. 2-1) so that the index mark on the knob is aligned with the desired band mark silk screened on the panel.

With the band selector on the desired band, the tuning dial should now be examined. (Fig. 2-1)

The FT-101 tunes 500 kHz segments of a given band, and as it comes from the factory, it is set up with crystals providing the following coverage: (See Fig. 2-3)

160m	1.5 to 2.0 MHz	(white)
80m	3.5 to 4.0 MHz	(red)
40m	7.0 to 7.5 MHz	(white)
20m	14.0 to 14.5 MHz	(white)
15m	21.0 to 21.5 MHz	(white)
11m	27.0 to 27.5 MHz	(white) (early model)
10A	28.0 to 28.5 MHz	(white)
10B	28.5 to 29.0 MHz	(red)
10C	29.0 to 29.5 MHz	(white)
10D	29.5 to 30.0 MHz	(red)

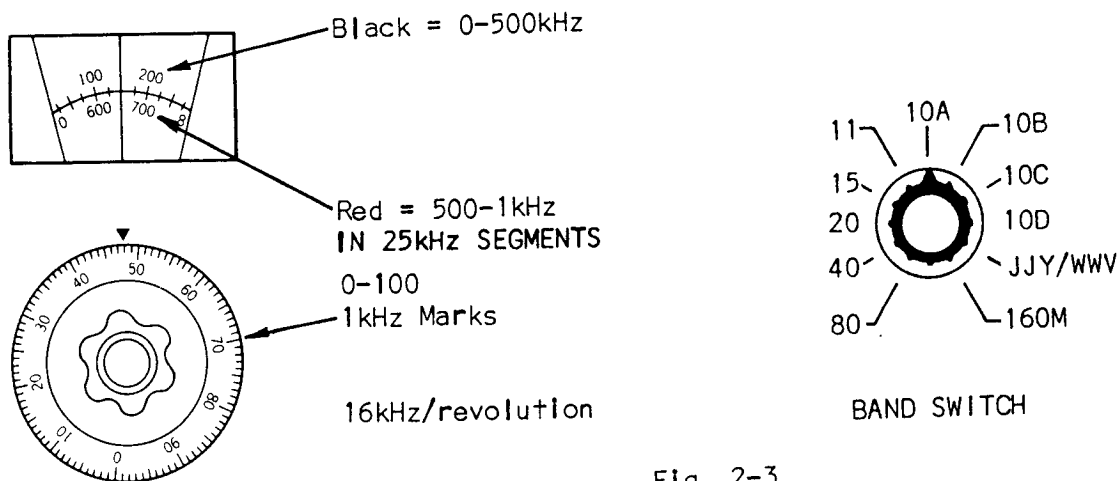

Fig. 2-3

## NORMAL TUNE UP

In addition to the usual rig tune up we gave you on pages 1-6 and 1-7, some additional data will help you to get maximum pleasure from your FT-101.

For example, to set up the FT-101E's RF Processor, begin with the PROCESS switch OFF, set the METER switch to ALC position. Speaking normally into the microphone, set the MIC GAIN control to the level where the meter indication stays in green portion of the meter scale. Set the PROCESS switch ON and adjust the LEVEL (processor output level) control to the position where the ALC indication stays in the green portion. Optimum setting of the MIC GAIN and LEVEL controls may need observation of the transmitted signal by the scope.

### 160 METERS

You will find the tuning is pretty critical on this band. The preselector is quite sharp, and the kind of antenna you are using may make your final and load controls equally touchy.

#### **CAUTION**

Don't exceed 140 ma plate current when you are between 1820 kHz and 1900 kHz or your spurious will exceed the -40 dB spec limit.

Don't exceed 330 ma on 80, 40, 20 or 15 meters, and don't exceed 280 ma when on 10, or you will risk those pesky pink tickets, or official observer cards.

If you get a report of a spur, check it out promptly, and keep your A-1 operator status shiny bright.

When inserting CARRIER for CW or AM mode, be sure you don't move the CARRIER control arm when you are turning up the MIC GAIN (or vice versa).

At least a minimal understanding of the importance of antenna feed and matching is necessary for the technician, even if he never sees the rig in actual use, to help identify "mysterious problems".

dBm is used when referring power to  $1\text{mW} = 0\text{dBm} = 1\text{mW}$  across a known resistive load, such as 50 ohms. However, most SWR meters indicate a voltage ratio, and thus readings are expressed as a "VSWR" for a given set of conditions.

Typically, an amateur uses a coaxial feedline to his antenna, and seldom takes into consideration any of the problems the cable can cause if it becomes open or shorted along it's length.

Similarly, failures in certain trap antennas, or "loaded" antennas can cause the rig to work perfectly on your test bench into a dummy load, but when taken home and set up on the defective antenna, the original complaint is back (ever heard this before? HI).

Some owners are clever enough to put two and two together, and not bother you again, correctly discerning that the problem is exterior to the FT-101, and no amount of "repair" on the rig will solve it.

But, at some point you will have to do some troubleshooting right on the spot, in the shack, and without your reference library.

Assuming you were clever enough to bring along this manual, here's how to proceed.

First, make sure the rig is grounded at the chassis ground point, with a heavy braid wire less than 10 feet long. (Do not ground to water pipes)

Now install a VSWR bridge in series with the coax, tune up the FT-101 on the band of interest, then cut back your power with the CARRIER control to the minimum that will let you get a full scale forward reading on the SWR bridge. Remember, you are "on the air", and potentially creating interference, so don't clog the CARRIER on and leave it on any longer than is necessary! (Check frequency first, to make sure it is not in use).

Now read your forward-reverse conditions. If the VSWR is 1.5 or below, shut down the rig and disconnect the feedline at the rig, and at the antenna. Check it for open/short conditions with an OHM meter. If it is OK, put the VSWR bridge into the line right at the antenna, and check again.

At resonance, the VSWR will be very, very low, but as you vary the frequency (above or below) it will shift, but not go more than 1.5 at the band limits. (If it does, prune or adjust the antenna until it stays below that point).

Most problems of this nature turn out to be so simple that you tend to overlook them: open outer braid (or oxidized copper) at the connectors, pinched or cut coax, shorted loading capacitors in the traps, or horribly mismatched antennas. Some examples:

Several "RF in the shack" or, "my mike bites me on the lip" complaints were found to be caused by trying to use CB (27 MHz) antennas on 10 meters (28 MHz) without retuning the antenna.

One "impossible SWR" situation was cured by replacing the feedline, which upon careful examination later proved to have a straight pin (installed by a neighbor, no doubt) buried in the coax, but only intermittently touching the center conductor.

To help you with the dB answers:

<u>dB</u>	<u>VOLTAGE or CURRENT RATIO</u>	<u>POWER RATIO</u>
3	1.41	2
6	2	4
10	3.16	10
20	10	100
30	31.6	1000
40	100	10,000
50	316	100,000
60	1000	1,000,000



# ASSEMBLY/INTERCONNECTION

## SECTION 3

CONTENTS	PAGE
OUTER COVER REMOVAL . . . . .	3-1
FRONT PANEL REMOVAL . . . . .	3-1
MAIN DIAL ASSEMBLY . . . . .	3-4
SWITCH PANEL ASSEMBLY . . . . .	3-5
PILOT LIGHT REPLACEMENT . . . . .	3-6
VFO REMOVAL . . . . .	3-8
INTERCONNECTIONS BETWEEN FT-101 AND:	
a. FV-101, SP-101P, FL-2000B (or FL-2100) . . . . .	3-9
b. MICROPHONE WIRING . . . . .	3-9
c. FTV-650 (WITH NECESSARY WIRING CHANGES) . . . . .	3-10
d. YC-601, FV-101 . . . . .	3-11
e. FTV-250, FT-650B . . . . .	3-12
f. FV-101B, SP-101PB, FL-2100B . . . . .	3-12
g. FR-101 . . . . .	3-12
h. YO-100 . . . . .	3-13

**For Service Manuals Contact**  
**MAURITRON TECHNICAL SERVICES**  
8 Cherry Tree Rd, Chinnor  
Oxon OX9 4QY  
Tel:- 01844-351694 Fax:- 01844-352554  
Email:- enquiries@mauritron.co.uk

## ASSEMBLY-DISASSEMBLY (COVERS)

1. Look at the exploded view shown in Fig. 3-1, remove the top plate by turning the two captive screws counter clockwise until they release, then lift the plate away.
2. Remove the bottom plate by first removing:
  - a. Two (2) 3mm hex nuts
  - b. Four (4) metal screws
  - c. Two (2) painted head Phillips screws
3. Remove the wrap-around cover by removing the four metal screws and the remaining four painted Phillips screws, and sliding the cover off the unit toward the rear.
4. Store and protect the covers to avoid damage to the finish. While it is off the unit, take the opportunity to wash the covers free of any accumulated dirt, grime and if possible, touch up any existing marks, or scratches. It helps the resale value, as well as keeping the shack looking sano.
5. Vacuum out any accumulated dust - a clean rig will help you locate part identifications, and improve the cooling capability of the FT-101 when you put it back into operation.

Now, if you really get into a major effort, and the front panel has to come off next, Fig. 3-2 will show you how it's done.

## ASSEMBLY-DISASSEMBLY (FRONT PANEL)

NOTE: Use a box or pan, so all the hardware will stay together, and be there when re-assembly time comes.

After you have taken off all of the covers, remove the 12 flat-headed Phillips screws holding the trim ring in place, set the rig on the bench with the front hanging slightly over, and gently work the trim ring loose. Remove and store. (Careful - it warps easily if you twist it too much).

Next, remove the knobs, beginning with the main dial assembly, which will give you no trouble if you study Fig. 3-3 and see how it goes together (and comes apart).

Remove the shaft nuts, as shown, and unsolder the leads to the microphone connector, and the pilot light.

Don't lose the bearing from the load control shaft, as so often occurs. Put it into the box with the nuts, washers and knobs. Remove the plastic film protector (if it's still in place).

You should now be able to gently detach the painted panel, revealing the screws for the switch deck (see Fig. 3-4). "Fantastik" or "409" detergent makes a nice clean panel, if it looks grimy from use.

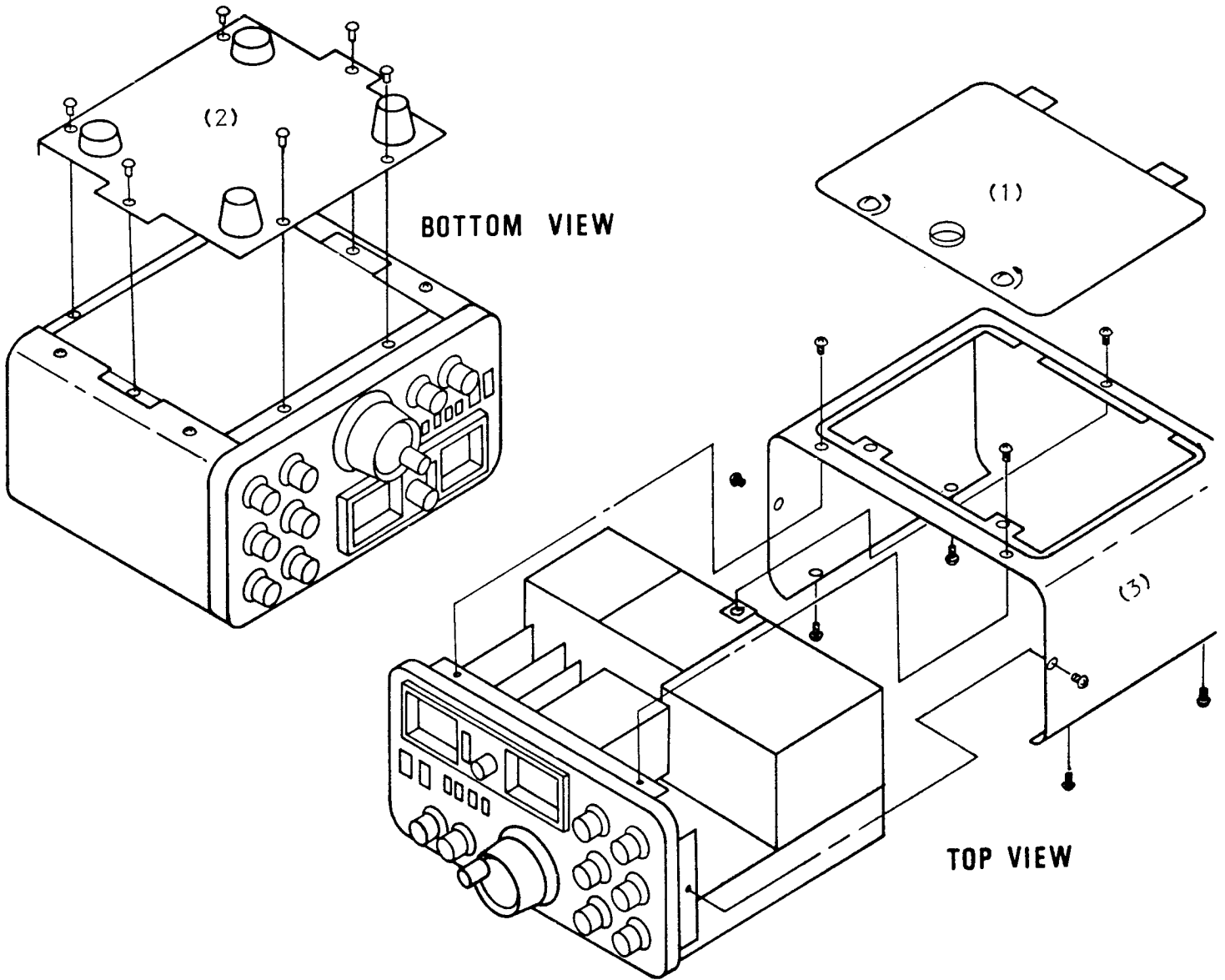
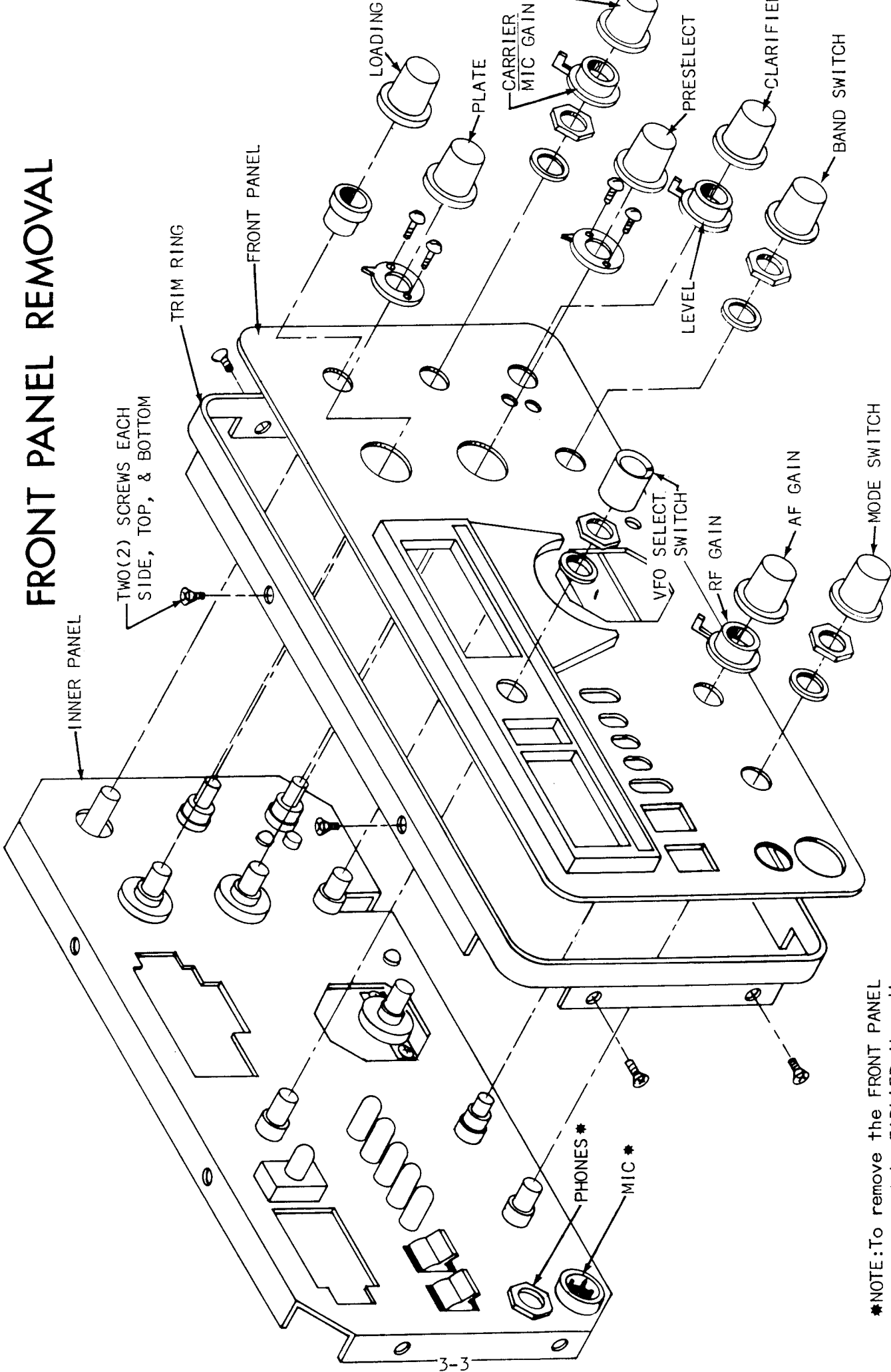

Fig. 3-1

For Service Manuals Contact  
**MAURITRON TECHNICAL SERVICES**  
 8 Cherry Tree Rd, Chinnor  
 Oxon OX9 4QY  
 Tel:- 01844-351694 Fax:- 01844-352554  
 Email:- enquiries@mauritron.co.uk

# FRONT PANEL REMOVAL



\*NOTE: To remove the FRONT PANEL on models EARLIER than the FT-101E the MIC & PHONES JACKS must be DISCONNECTED & REMOVED from the FRONT PANEL.

MAIN DIAL ASSY. CAN BE SEEN IN FIG. 3-3.

FIG. 3-2

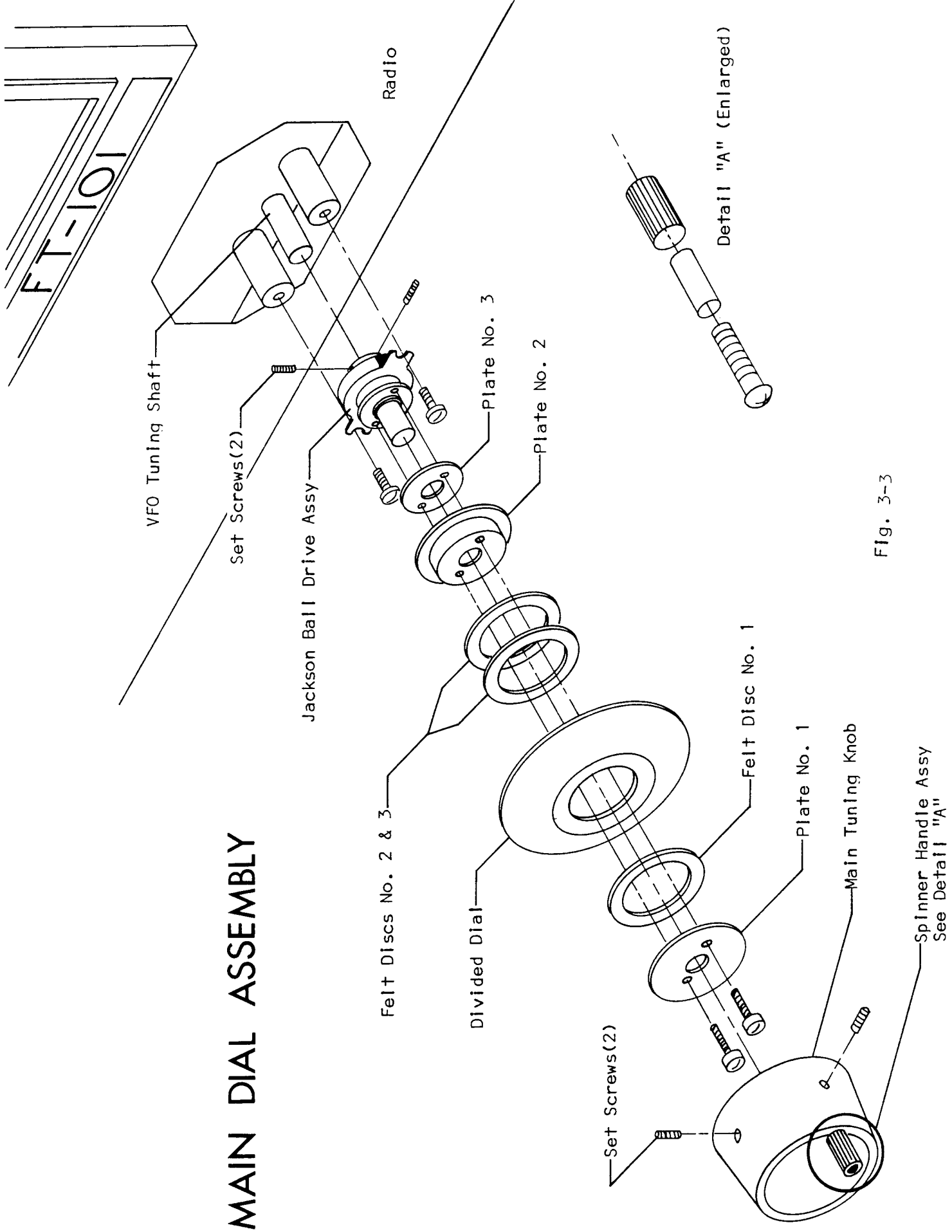
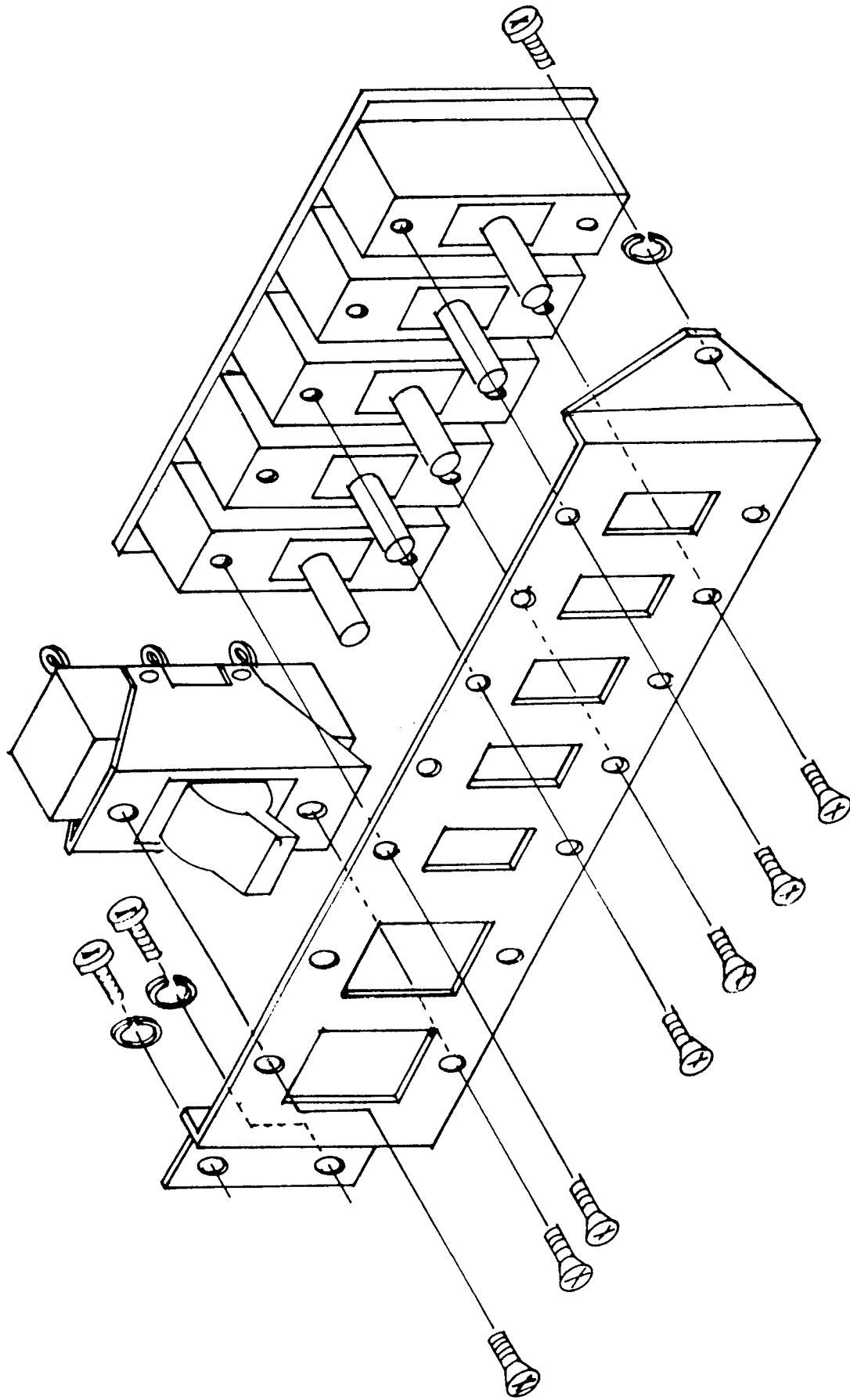

Fig. 3-3



Front Panel  
Switch Assembly

Fig. 3-4

## PILOT LIGHT REPLACEMENT

As often pointed out, the pilot light replacement in an FT-101 is not a simple two minute job, but then it is not the major effort that some would have you believe it to be either.

First, get the right bulb(s). The FT-101 uses:

- 1 - 14V 40ma wire lead type for the triangle light
- 3 - 16V 150ma bayonet type bulbs

Two of the lamps are a breeze; just plug them in and away you go. The third 16V bayonet bulb however, is really an RF fuse, and it's located on the rear panel. More than one inquiry has come in asking "where does the other light go"?

Installing the wire lead 14V lamp is a bit more complicated, but look at Fig. 3-5 and it should become clear as to what to do.

Remove the main tuning knob and the two screws holding the plastic es-cutchion in place, tug out the old bulb, press in the new, and route the wires as shown.

If your unit used tape to hold the bulb in place, you can use Scotch masking tape as a replacement, however, don't glue it into place, or it will bond so firmly to the plastic that replacement will become impossible. Use the tape, or block, whichever was supplied.

**CAUTION**

## PCBA REMOVAL/REPLACEMENT

**CAUTION:** The boards are not keyed, and it is possible to install the wrong board into the wrong socket, so if you have two or three boards out at once, check section 5 and make sure they are re-installed into the correct holes, or serious damage could result.

For Service Manuals Contact  
**MAURITRON TECHNICAL SERVICES**  
8 Cherry Tree Rd, Chinnor  
Oxon OX9 4QY  
Tel:- 01844-351694 Fax:- 01844-352554  
Email:- [enquiries@mauritron.co.uk](mailto:enquiries@mauritron.co.uk)

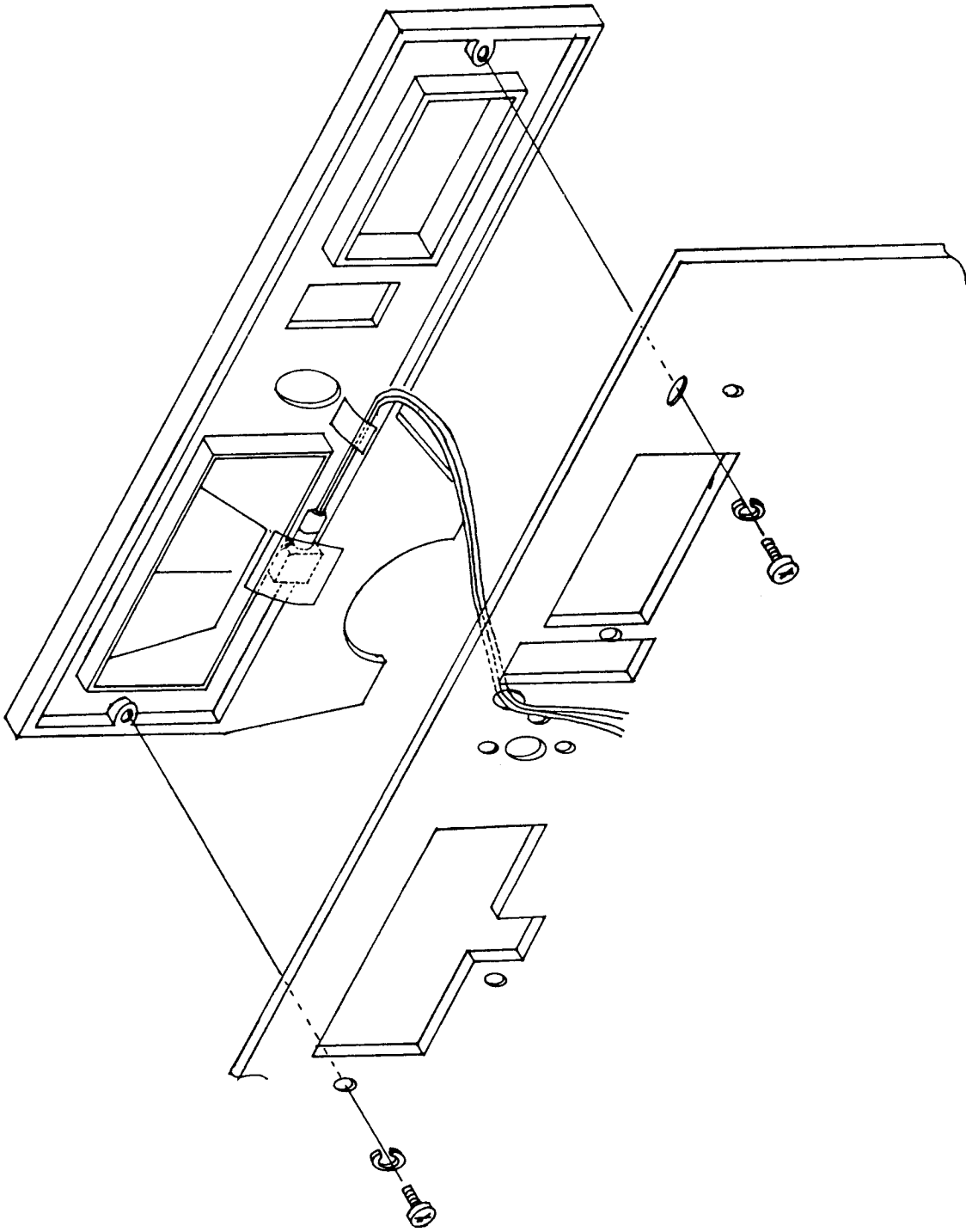

Escutcheon & Pilot Light  
Assembly

Fig. 3-5



## VFO REMOVAL

Remove the front panel assembly, and tilt the inner panel forward about 45 degrees. Remove the three hold down screws, unsolder the coax and 6 volt lines, and lift straight up, tilting the gear assembly down to clear the panel assembly. (Fig. 3-6)

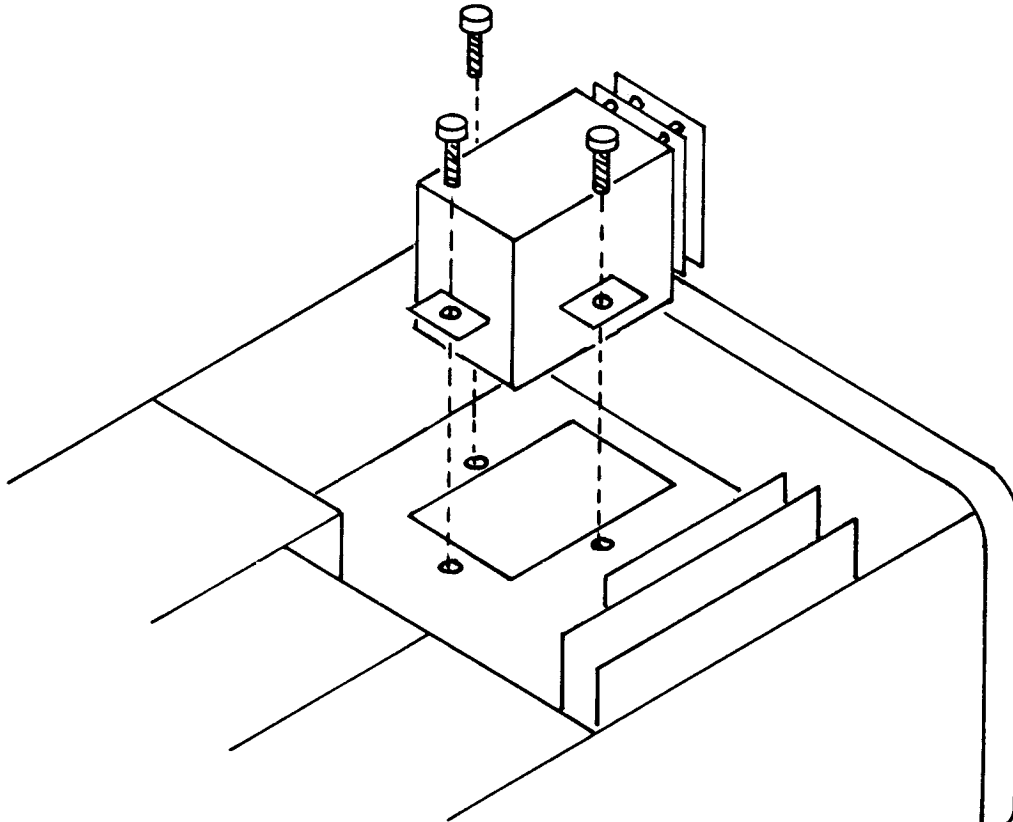

For Service Manuals Contact  
MAURITRON TECHNICAL SERVICES  
8 Cherry Tree Rd, Chinnor  
Oxon OX9 4QY  
Tel:- 01844-351694 Fax:- 01844-352554  
Email:- enquiries@mauritron.co.uk

Fig. 3-6

## INTERCONNECTIONS

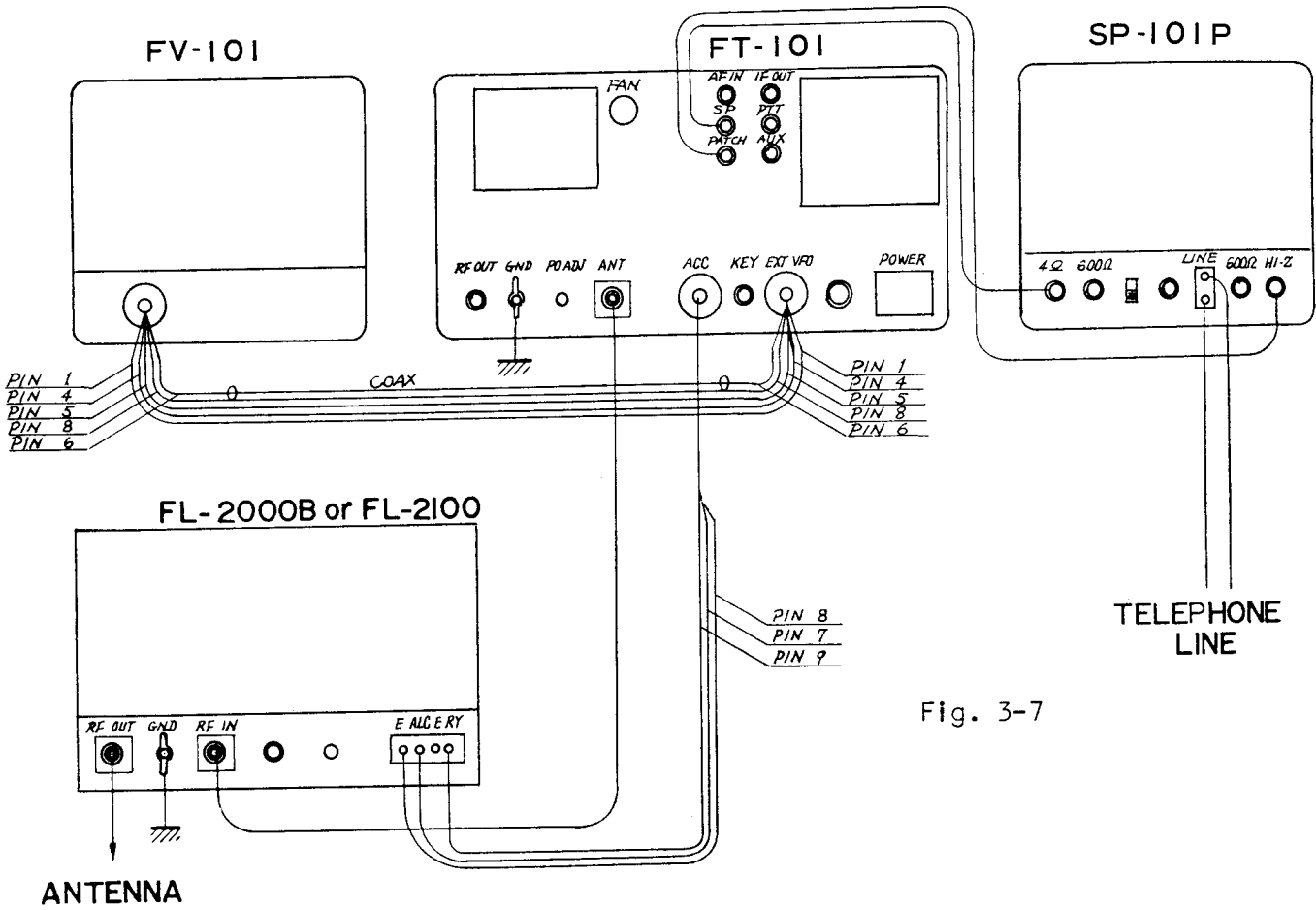

Fig. 3-7

## INTERCONNECTION DIAGRAM

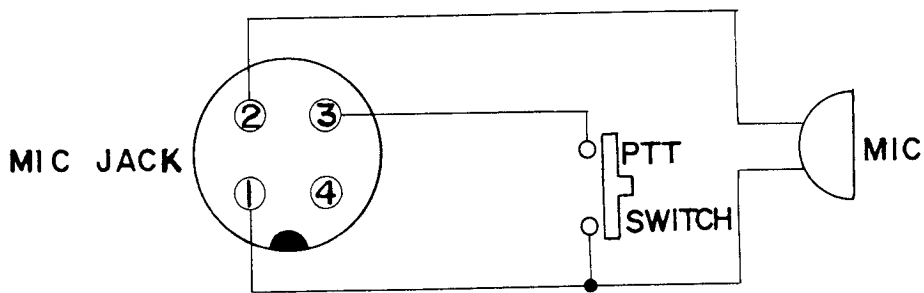

Fig. 3-8

## MICROPHONE CONNECTION

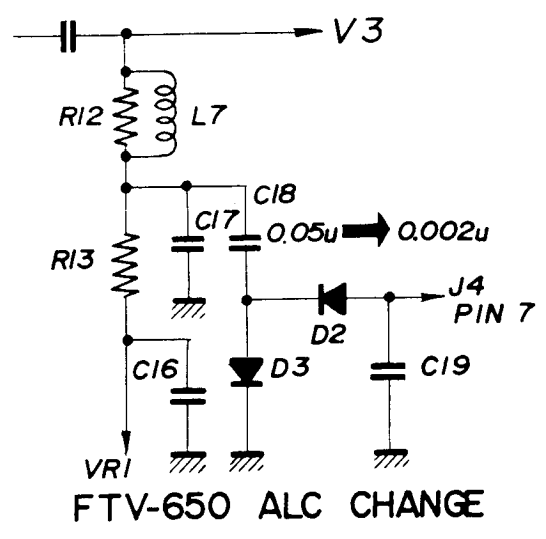
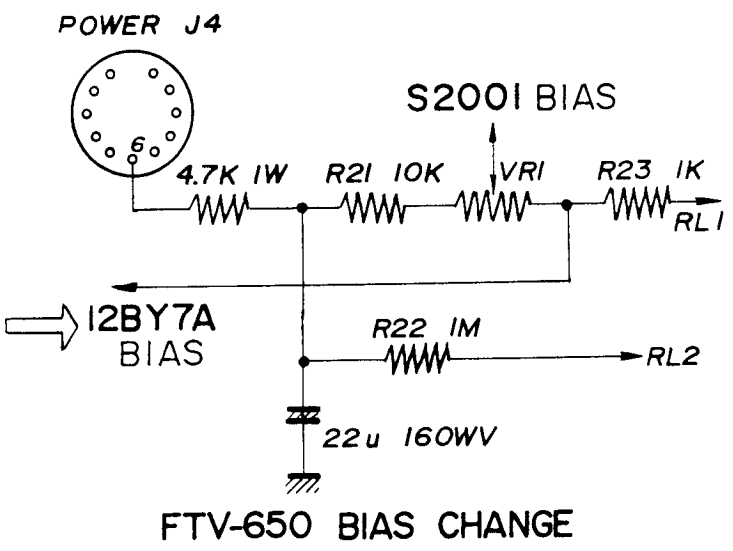
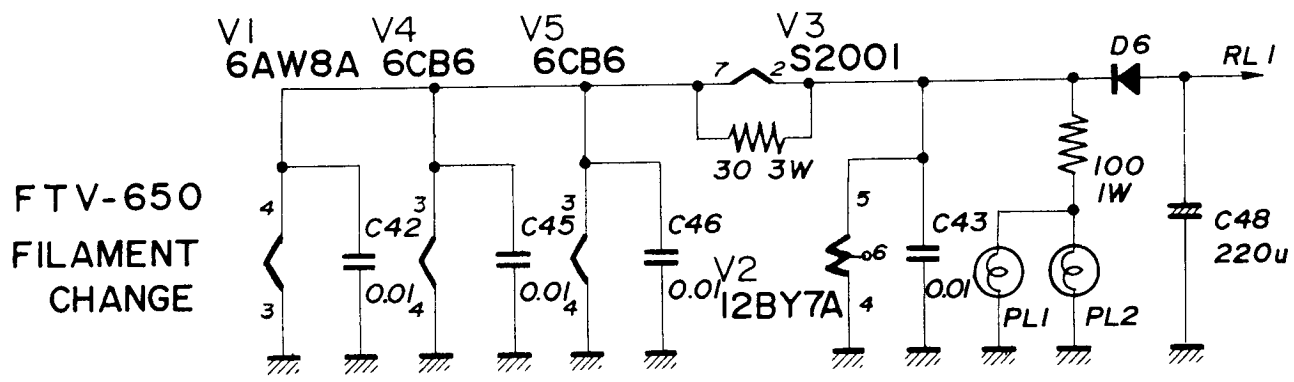
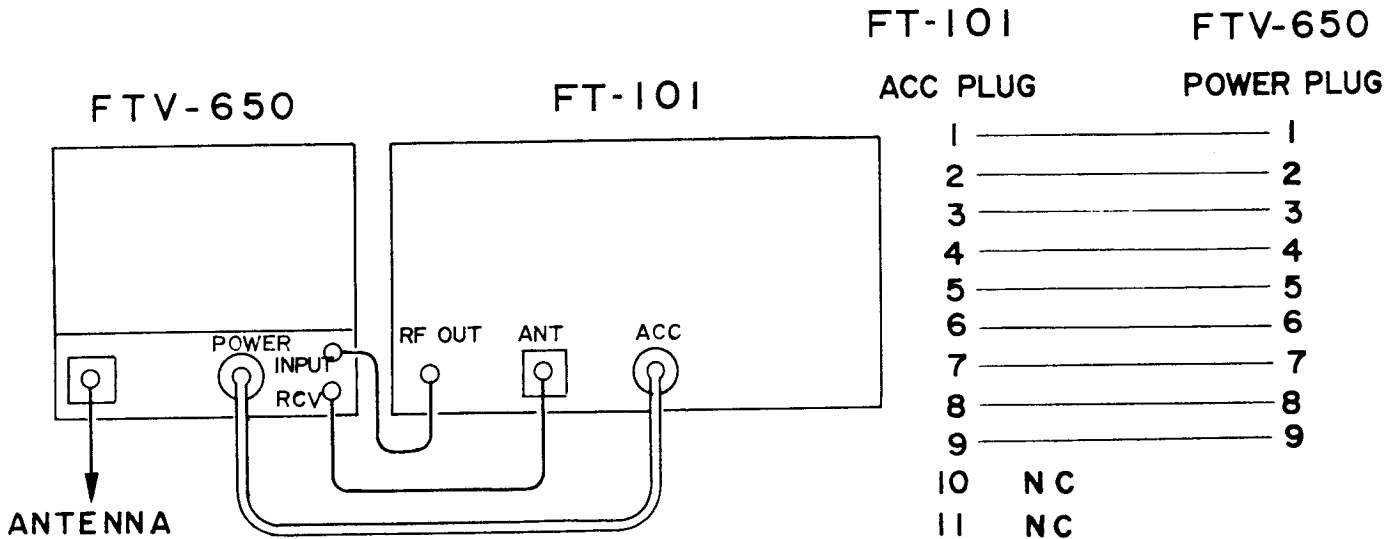

Fig. 3-9

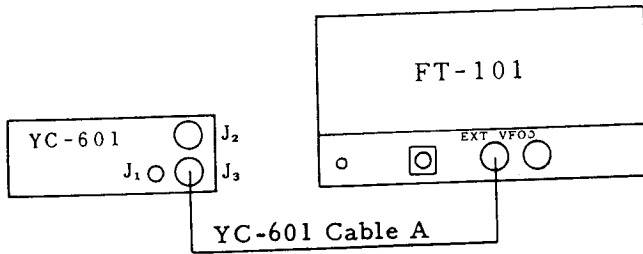

Fig. 2

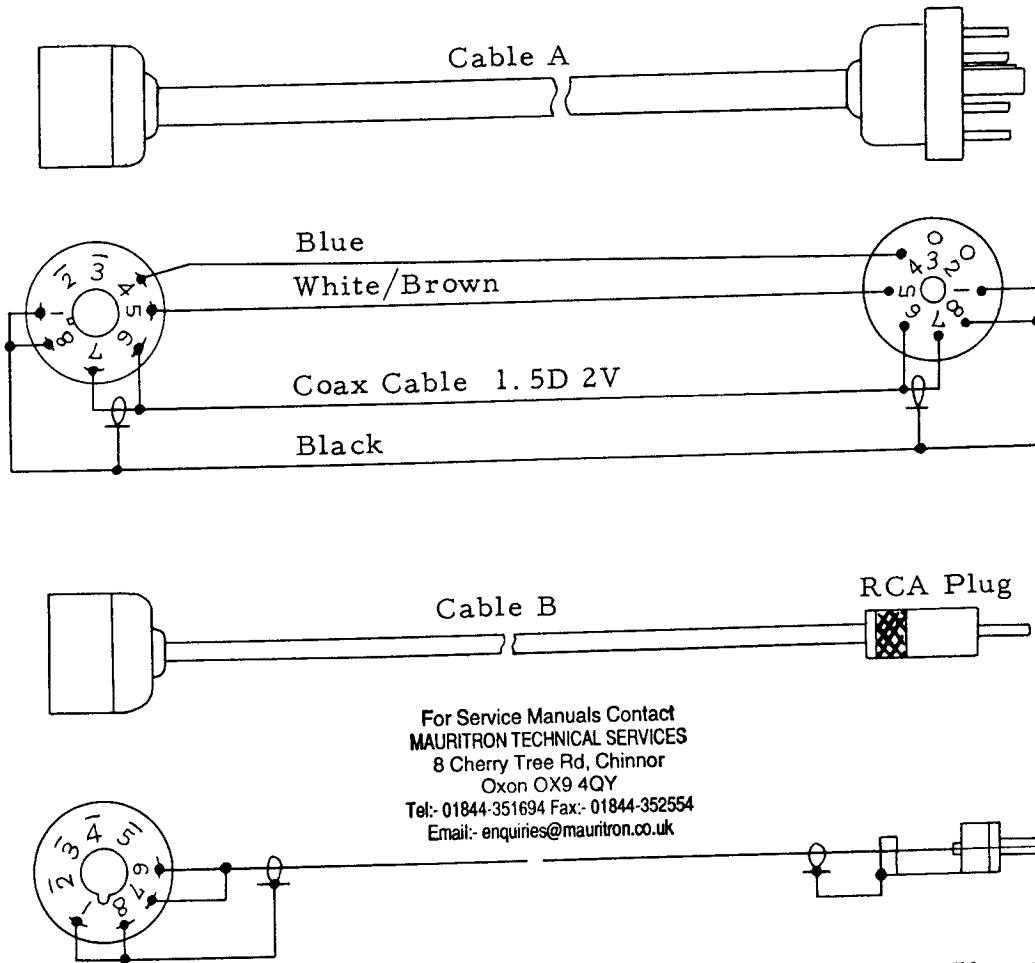
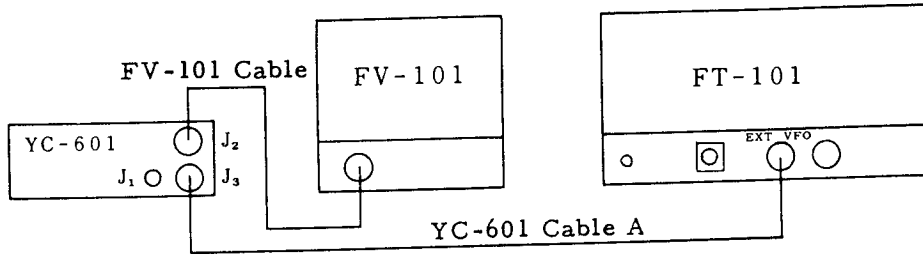

Fig. 3-10

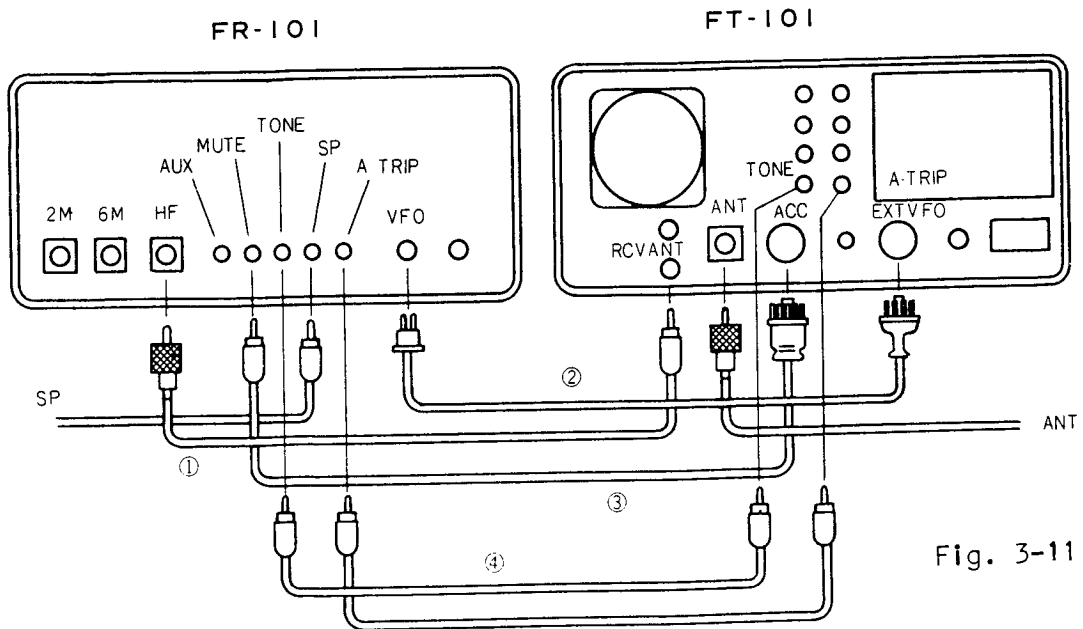
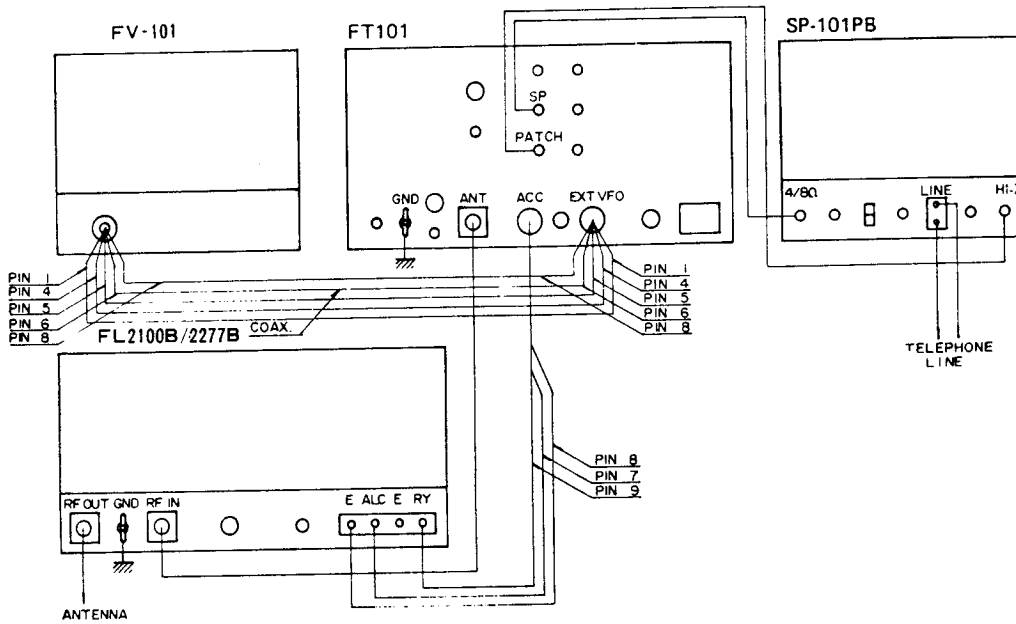
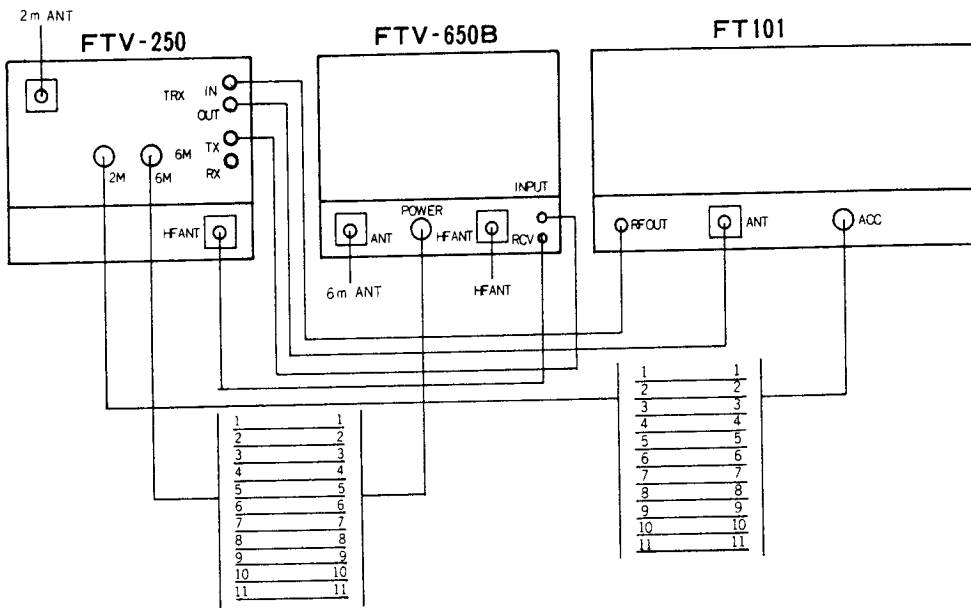

Fig. 3-11

## INTERCONNECTION OF THE YO-100 AND FT-101

The YO-100 hookup varies, depending on the particular application involved. The instruction manual is somewhat hazy in its descriptions of how to go about various setups, so a few words are required to clear up the questions.

The YO-100 set up to monitor the FT-101's transmitted signal when transmitting, and display the received signal, when in the receive mode is the most common setup and should be wired in as shown in Fig. 3-14.

NOTE: Modification of the board is necessary on all FT-101 versions. The "IF OUT" jack does not provide enough signal to the YO-100 to provide adequate deflection.

### FT-101 MODIFICATION

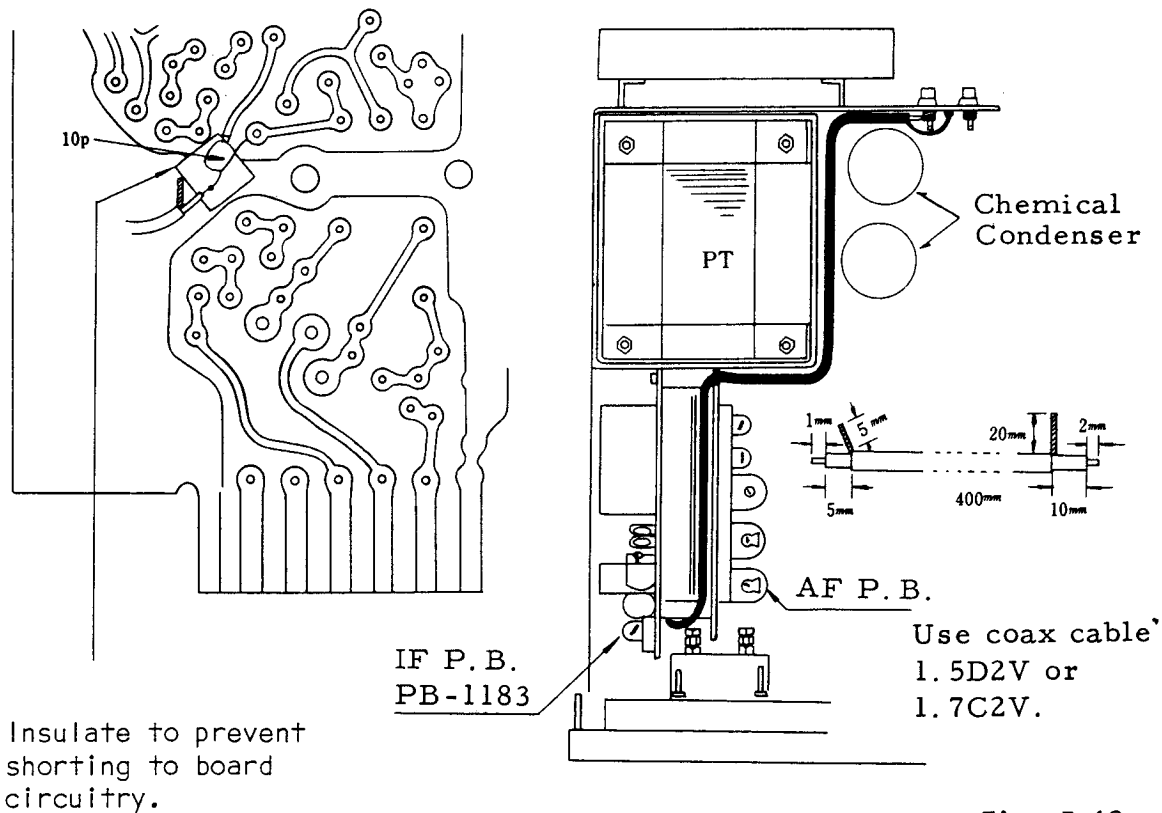

Fig. 3-12

The received pattern may not be identical to the transmitted pattern, since the received signal passes through a sharp filter in the receiver IF section and also is affected by the receiver AGC section.

The bandwidth of the receiver IF filter affects the display of the actual transmitted signal. The IF bandwidth would be required to be 10 times the actual modulated signal in order to prevent distortion. This means that a 3 kHz filter can only produce 300 Hz signal without distortion.

So use caution in signal evaluations, since a flat topping SSB signal may be received and displayed as if it were acceptable on the RF envelope pattern.

With the AGC ON, the leading portion of the waveform may be displayed with higher amplitude than normal. This problem can be minimized if the RF gain is reduced sufficiently to prevent over loading.

#### RECEIVER PATTERNS (SHOWING SEVERE FLAT TOPPING)

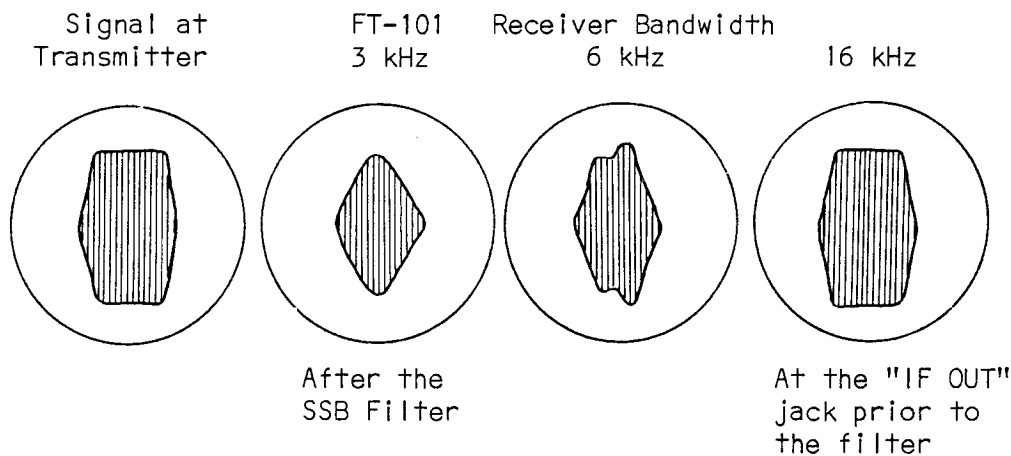

Fig. 3-13

For Service Manuals Contact  
**MAURITRON TECHNICAL SERVICES**  
8 Cherry Tree Rd, Chinnor  
Oxon OX9 4QY  
Tel: 01844-351694 Fax: 01844-352554  
Email: enquiries@mauritron.co.uk

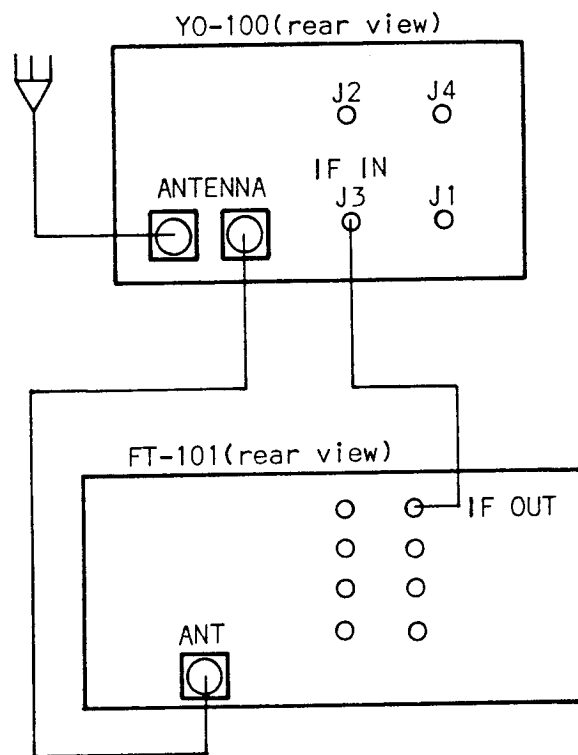

FIG. 3-14

For Service Manuals Contact  
**MAURITRON TECHNICAL SERVICES**  
 8 Cherry Tree Rd, Chinnor  
 Oxon OX9 4QY  
 Tel:- 01844-351694 Fax:- 01844-352554  
 Email:- enquiries@mauritron.co.uk



# LOCALIZING TROUBLES IN THE UNIT

## SECTION 4

CONTENTS	PAGE
FAULT IDENTIFICATION AND LOCALIZATION . . . . .	4-1
SIGNAL TRACING THROUGH THE FT-101 . . . . .	4-2
NOISE BLANKER CIRCUITS . . . . .	4-4
ALC OPERATION . . . . .	4-7
ALC TROUBLESHOOTING . . . . .	4-7
ADVICE ON TROUBLESHOOTING THE FINAL/DRIVER . . . . .	4-11
FINAL AMPLIFIER NEUTRALIZATION . . . . .	4-12
FAULT TREE Rx . . . . .	4-13
FAULT TREE Tx . . . . .	4-14
FT-101 CHASSIS VOLTAGE CHART . . . . .	4-15
FT-101 CHASSIS RESISTANCE CHART . . . . .	4-16
FT-101B/E/EE/EX CHASSIS VOLTAGE CHART . . . . .	4-17
FT-101B/E/EE/EX CHASSIS RESISTANCE CHART . . . . .	4-18
BOARD AND TUBE VOLTAGES . . . . .	4-19

## FAULT IDENTIFICATION AND LOCALIZATION

The process of troubleshooting any electronic equipment is highly individualistic, however, it is essentially a process of logical elimination.

Begin with a visual inspection for broken, discolored or charred components. Smell the unit. (Transformers smell differently than resistors, etc). Check for loose modules or tubes.

Set up the unit as shown in Fig.4-13 and be sure to use a dummy load. Do not troubleshoot using an antenna.

Initially, turn on the receiver only, and check out the entire Rx side of the transceiver. Repair anything you detect as a malfunction in the receiver, before attempting to repair or key up the transmitter side.

Since much (most) of the circuitry is used for both Tx and Rx, you may clear a Tx fault at the same time you are repairing the Rx malfunction.

The technique to follow when trying to identify a fault is to first localize it to a function (Rx inoperative on LSB) then to a board, (MOD and OSC unit) a circuit, (LSB oscillator) then a component (2SC372Y). If you get lost, back up and begin again, using the data given in this manual to help you.

Naturally, if the Rx is normal, move to the Tx side and troubleshoot it the same way (function - board - circuit - component). Doing the Rx first, eliminates fully 80% of the problem, so you can concentrate on the 20% unique to the Tx side.

Once you have localized the problem to a board, using the "Fault Tree", find the appropriate drawing of it in Section 6. Using an extender board (available from Yaesu) check for correct DC voltages at the edge connector. If they are correct, but the board still is inoperative, use an RF probe on your VTVM and check the gains, as shown in each drawing.

Somewhere along the line you will discover an abnormal condition, and be able to trace it to a component. Locate the part, using the part location drawing, and remove/replace it, using care not to create lifted pads or solder bridges.

Re-install and test for operation. If you need to realign the board or stage, we have included the frequency data you need, right on the board drawing.

## SIGNAL TRACING THROUGH THE FT-101

Probably the most useful signal in the FT-101 series that most servicemen either overlook or fail to use to the maximum advantage, is the internal calibrator.

A quick look at the block diagram of the FT-101 will disclose that it is fed into the transceiver right at the antenna terminal, and in a normally operating FT-101 will read about "10 over S-9" on the meter when you are on 14.200 MHz. Knowing this little fact can immediately separate antenna problems from receiver problems in one quick move.

Factory techs rarely have recourse to a signal generator since with a little practice it is possible to do almost a full alignment of the receiver section, using the calibrate signal and with a little more practice, you can learn to pinpoint a blown FET or other receiver problems in moments.

We have re-done the block diagram to show you where the signals can best be verified, but the easiest way to get a defunct FT-101 back into a customer's arms is to carry a set of substitute boards. Just plunk in a new board, and mail the dud into a Yaesu Service Center. This is also a fairly expensive way, but it is fast and efficient.

The second technique is to use a set of extender boards and using the "fault tree" boil it down to a board, find out what voltage is missing/wrong, and replace the defective component. (Most owners and techs do this).

The third technique is to use this chapter and by finding where you lose the signal, identify the errant board, remove it, and find the defect by resistance checks. (Not many folks do this, because besides being slow and tedious, the success ratio is low).

This manual will allow you to use all three methods or even a combination, if you wish, to avoid using the fourth method.

The fourth method is packing the unit carefully and sending it to a Yaesu Service Center. This is recommended only if your rig is in serious trouble, and you have really used this manual to the best of your ability.

If you must ship it back, pack the unit well, using the original double boxes and styrofoam packing (if you have it yet) and insure it for full value.

Do not include cords, microphones, or manuals, but if you have some pet modifications installed, we will leave them in place if you tape a note to the side of the rig (not the box) to that effect.

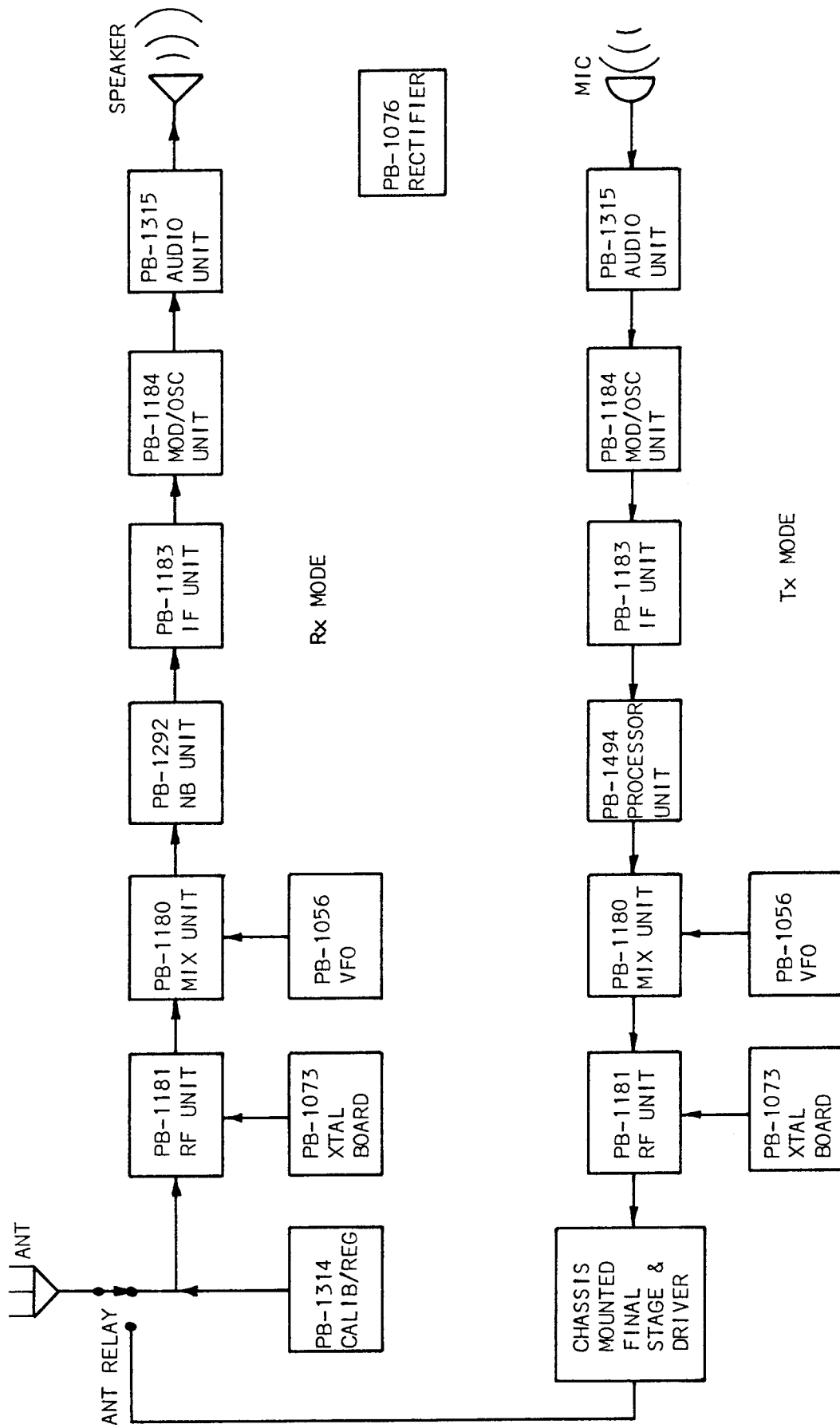

Fig. 4-1

## NOISE BLANKER CIRCUITS

### GENERAL

From the earliest FT-101 to the present, a noise blanker circuit has been a feature of Yaesu transceivers and receivers, but it's location has moved about a bit, and servicing will be simplified if the repairman has a good understanding of the various circuits and configurations found in these units.

### FT-101 (Early)

The noise blanker was part of the PB1080 low frequency IF board on this model, and consisted of only one transistor, (Q6) a 2SC372Y. Some versions used a 2SC828P which had a somewhat improved rise time characteristic, but it took a fine tuned ear to notice any change in effectiveness, which was not too much, at best.

### FT-101 (Late)

As a result of increasing mobile use, the noise blanker was given considerable attention, and the result was creation of an entire new board, PB1182. Since the new circuit was too large for the old board (PB1080) and too small to entirely occupy the new, the fixed crystal circuit was also added, and the board configured to lie on top of the VFO assembly. This, incidentally is a simple and quick means of identification of late versions of the FT-101. This was not a "plug-in" module as were later versions, but had to be hard wired in to position.

### FT-101B/E/EE/EX (Early - Mid)

With the major redesign that the "B" version represented, an additional socket was added for the noise blanker in the space between the VFO and the chassis mounted filter capacitors. This edge mounted board was designated PB1292 and was used in Yaesu FT-101B/E/EE and EX.

In August 1976 production runs of the FT-101E/EE/EX, (and thereafter) a new blanker was developed and produced, the PB1582.

All the previous blankers had functioned at the 3180 kHz IF frequency, however, the new unit (PB1582) used a 2725 Hz local oscillator, and stepped the frequency down to 455 kHz for noise blanking ability and makes a fairly low cost "update" of any FT-101 currently using the PB1292, since the units are directly interchangeable.

The early production of PB1582 boards revealed that it had an inter-mod problem, which fortunately was easily cured by modification of the on board AGC circuit. The "Before" and "After" circuit is shown in the modification section of this manual. S/N 200000 to 208120 were modified in the USA, with units after that arriving with the factory mod already in place.

## PB1582 BLANKER

The noise blanker PB1582 operates through the detection of steep sided noise pulses, then closing off the IF amplifier until the pulse has died down to the ambient (inherent or signal) level.

While well known as the "Lamb Silencer" in 1938, the advent of solid state technology has provided the designer with an improved "noise blanking" technique.

Fig. 4-2 is a block diagram of the new PB1582 circuit, to help illustrate the signal flow.

The 3180 kHz IF signal is brought into the board via pin 4, and coupled to both the IF amp, and the pulse detector circuit simultaneously.

The signal through the IF is coupled into the impedance matching transformer T120, through a 3 pf capacitor, C1. The secondary of T120 drives the base of Q1 (2SC372Y). The 3180 kHz signal is then fed through T121 where two diodes, D1 and D2 (1S188) act as gate diodes.

Assume that the blanker is off, and a ground has been placed on pin 6, through switch S-3.

This in effect, grounds the center-tap of transformer T122, and allows the 3180 kHz IF to flow through the 27 pf coupling capacitor to the second IF stage, Q2 (2SK19GR) and out of the board through C9 (100P) and pin 1.

The noise blanker is activated when the ground is removed from pin 6, and applied to pin 8. This grounds gate 2 of the 3SK40M, which is acting then as a common drain coupled mixer, using a Pierce oscillator upper section, controlled by a crystal 2.725 MHz.

The incoming 3.180 MHz is heterodyned with the 2.725 MHz producing a resultant 455 kHz difference frequency. The sum frequency (5.905 MHz) is differentiated out through T123.

The IF signal is now exactly replicated at 455 kHz. This signal is amplified through Q4, (3SK40M) noise amp. The noise signal is coupled out through C20, and is rectified by D3 into an averaging DC signal, which after integration through R24, C23 is applied to the base as an AGC, or level establishing signal. Q5 amplifies the DC signal, producing about 11 volts at the test point and controls the gain of Q4 the noise amplifier.

The noise output is also applied to diode D4, however, only pulses exceeding the diode conduction resistance will pass through it, to gate 1 of Q6, the pulse amp. Noise pulses that do exceed this level cause Q6 to conduct, biasing Q7 into conduction and effectively grounding the signal, by placing a back bias on diodes D1 and D2. This causes a "hole" in the IF signal, instead of a large noise pulse.

Early reports by active amateurs disclosed that while the new noise blanker was highly efficient in cancelling out pulse type noise, a strong adjacent channel signal would create an IF overload situation, and broaden the response unacceptably. To correct this shortcoming, a modification was developed to improve the AGC range of the board which then restored the FT-101E to its previous selectivity, and retained its excellent noise blanking ability.

For Service Manuals Contact  
**MAURITRON TECHNICAL SERVICES**  
 8 Cherry Tree Rd, Chinnor  
 Oxon OX9 4QY  
 Tel:- 01844-351094 Fax:- 01844-352554  
 Email:- enquiries@mauritron.co.uk

NOISE BLANKER PB-1582

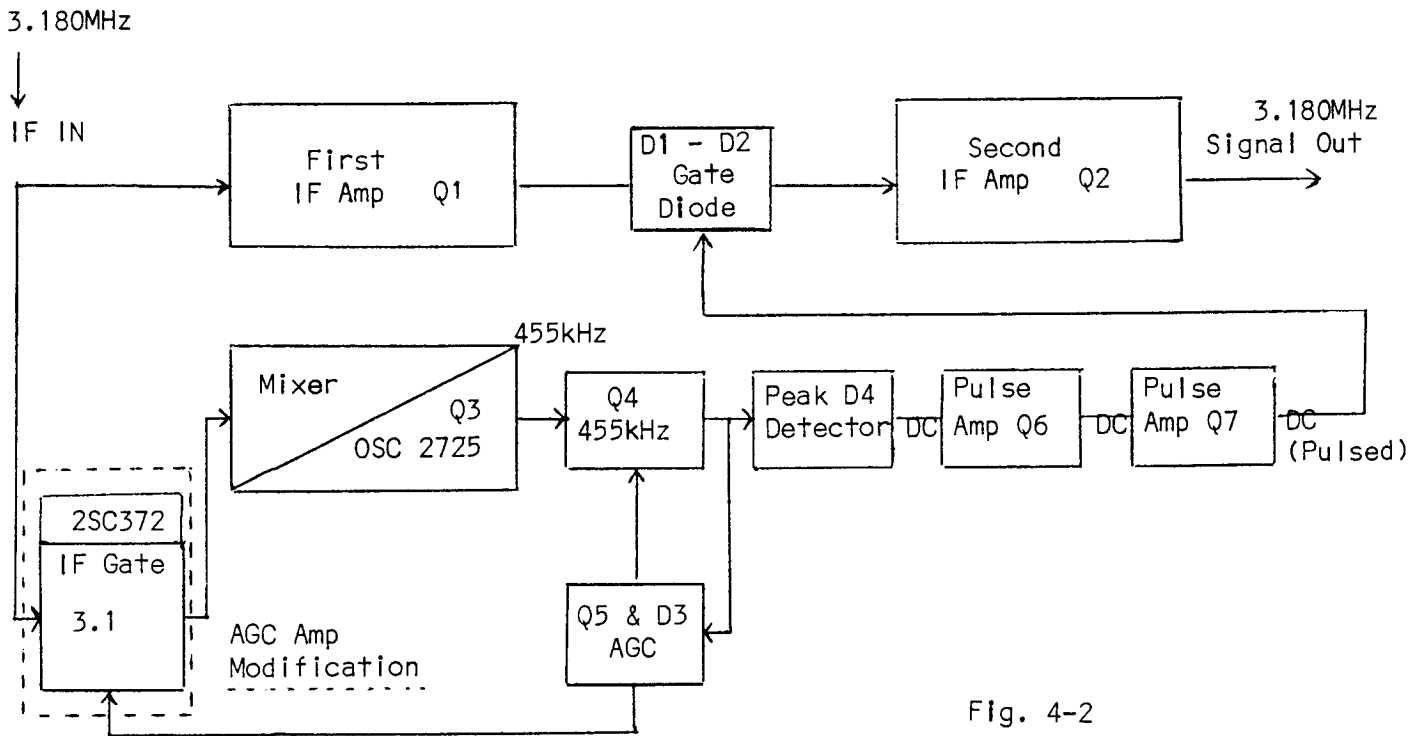

Fig. 4-2

## ALC OPERATION

The ALC action you see on your meter is a function of drive to the final grids.

V2 and V3, while biased and operating in a linear mode, will not draw grid current until they are over driven by excessive RF peaks. These excessive peaks are caused by normal peak voice passages or excessive mike gain. Both conditions will cause grid current to be drawn, which creates an AC voltage on the grid, coinciding with the voice peaks.

This voltage is coupled out through capacitor C-17 to the ALC voltage doubler diodes D2 and D3. C-17 acts as a blocking capacitor which keeps the negative bias voltage from entering the ALC circuit.

Under peak audio, a -1.5 VDC will be developed at the anode of D2. C-18 and R-13 form the ALC time constant, controlling the rise and decay time. The ALC voltage is then fed to pin 11 of MJ, the MOD and OSC board where it controls the bias on Q1 (2SK19) IF amplifier. This bias voltage on the gate of Q1 reduces the gain of the IF stage which results in a reduction of drive voltage to the final grids.

VR2 in the source circuit of Q1 is used to zero the ALC meter with Q1 in a quiescent condition. As ALC voltage is applied to the gate of Q1 varying it's output at an audio rate, the source of Q1 also follows these variations which are monitored by the ALC meter.

## ALC TROUBLESHOOTING

### ALC ADJUSTMENT

VR2 (ALC adjust) must be able to adjust ALC to the right hand index mark, indicating that the switching and metering circuitry is operating properly. On the FT-101E, using a PB1534, VR2 is located on the processor board, not on PB1184 where it is found on the EE/EX models.

### IDLING CURRENT

Idling current must be resting at 60ma USB or LSB mode, transmitter keyed on.

### TRANSMITTER POWER OUTPUT

Transmitter power output must be checked in the SSB mode. This mode is used because the ALC circuit is defeated in the TUNE/CW/AM mode. Whistling into the mike of a properly tuned system, should indicate from 130 to 150 watts output on a watt meter. If a watt meter is not available, 52 RF volts should be present at pins 5 and 9 of V2 and V3, indicating adequate drive to the finals.

The above conditions must be met to develop ALC voltages. ALC troubles fall into two groups: (1) normal power output and no ALC meter indications, or (2) low or no power output while operating in the SSB mode.



### NORMAL TRANSMITTER OUTPUT - NO ALC INDICATION

With the transmitter loaded and the mode switch in the SSB position, key the mike and advance the mike gain control to the number three position.

Whistling into the mike, measure the voltage at the anode of D2. This voltage should read -1.5 VDC on peaks indicating the ALC rectifier is working properly.

If zero volts is measured at this point, the following checks should be made:

Disconnect the white wire at the junction of R13, C18, and D2, and measure the voltage again while whistling into the mike. If the voltage is still zero, then one or more of the components in the ALC rectifier circuit is bad, (C17, D2, D3, C18 or R13).

If the voltage is normal with the white wire disconnected, this indicates a ground on the ALC output circuit. Unless the wire connecting the components is being shorted to the chassis, the only components that will cause this trouble are C32 and C6, which are located on the MOD and OSC board. Replacement of the bad components should restore normal ALC indication.

If the proper voltage is read at the anode of D2, then this voltage must be traced over to the gate of Q1 to locate the open component or circuit such as L12 or R4.

### LOW OR NO TRANSMITTER OUTPUT

If transmitter power output is zero in the SSB mode, and normal in the TUNE mode, it is possible that the unit has an ALC trouble.

With the transmitter loaded in the TUNE position, switch to the SSB mode and ground the anode of D2 ALC rectifier. Whistle into the mike and see if transmitter power output is back to normal. If so, C17 is leaky, causing final bias voltage to be fed into the ALC circuit. Replacing C17 should restore normal power output and ALC indication.

If grounding the anode of D2 will not restore normal operation, then a drive problem exists, and not ALC troubles.

### NORMAL TRANSMITTER OUTPUT - ALC METER WILL NOT RETURN TO ZERO

This trouble is usually caused by the value of C18 and R13 changing and increasing the ALC time constant.

If you experience erratic meter indications, but the transmitter output is normal, check the relay (RL-1). A "tired spring" will sometimes give this sort of indication.

# ALC CIRCUIT

## FT-101 & FT-101-B

Fig. 4-3

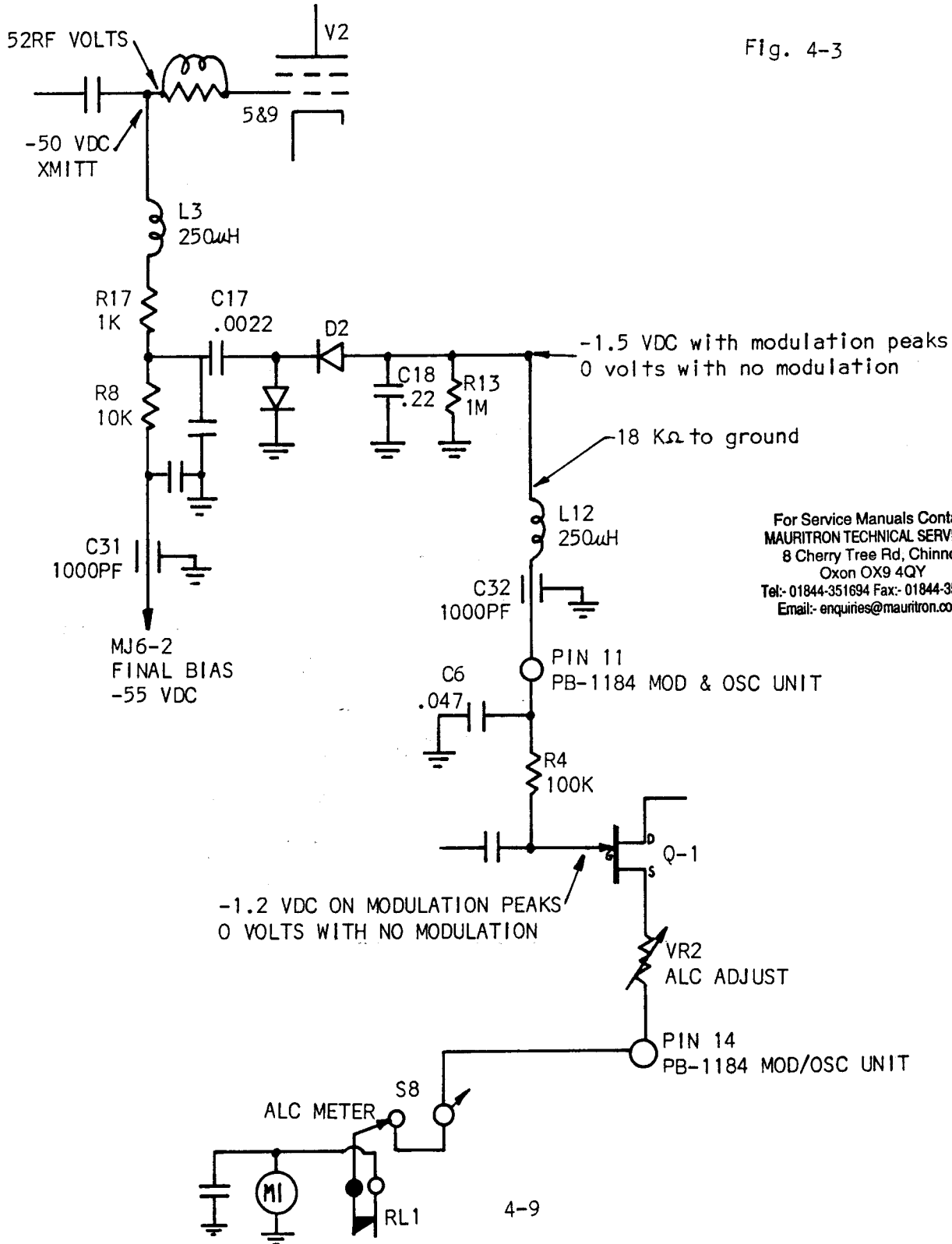

For Service Manuals Contact  
**MAURITRON TECHNICAL SERVICES**  
 8 Cherry Tree Rd, Chinnor  
 Oxon OX9 4QY  
 Tel:- 01844-351694 Fax:- 01844-352554  
 Email:- enquiries@mauritron.co.uk

# ALC CIRCUIT

FT-101E/EE/EX  
(Serial No.  
150001 & Up)

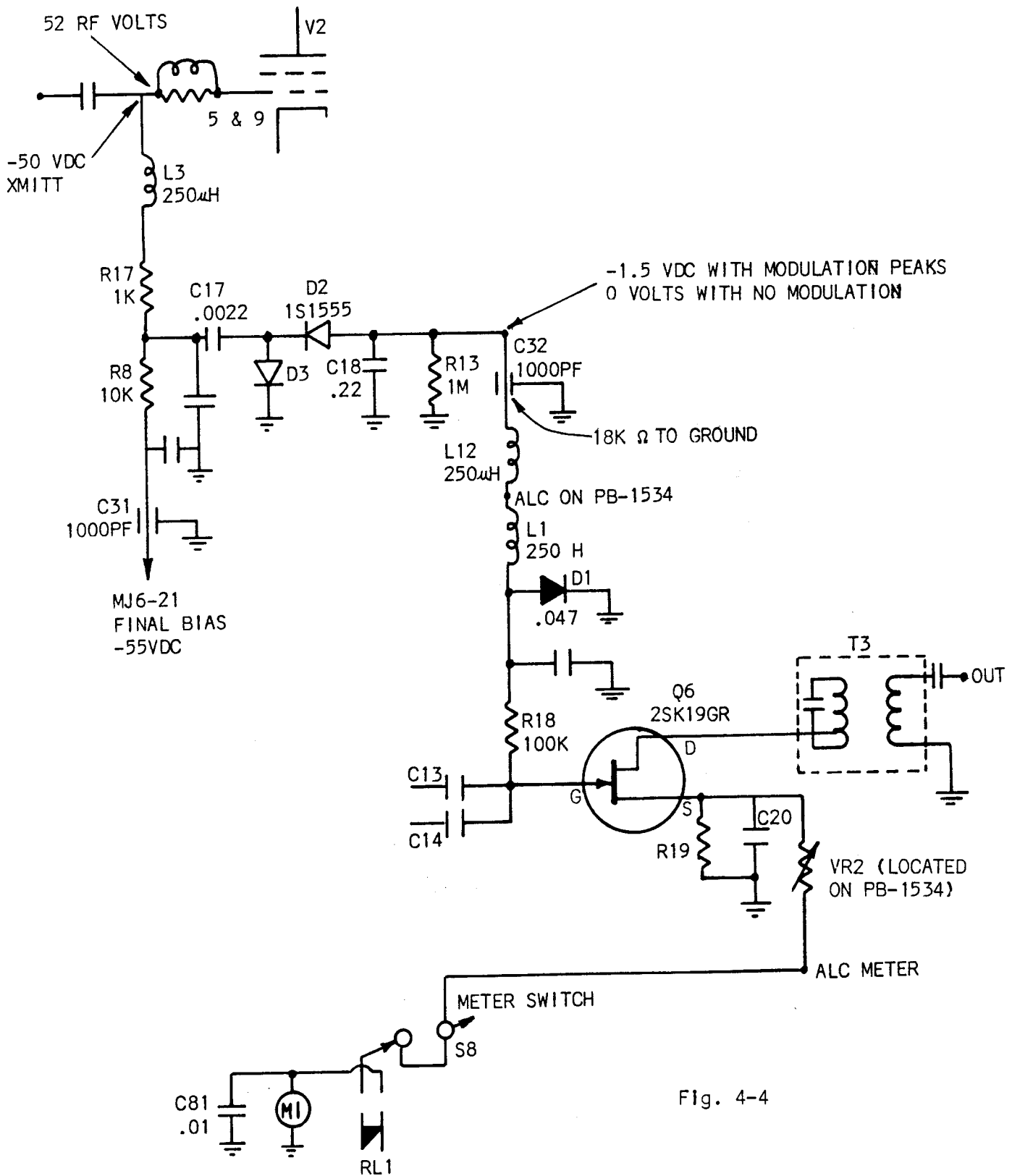

Fig. 4-4

## ADVICE ON TROUBLESHOOTING THE FINAL AND DRIVER

### FT-101 SERIES

There are only three tubes in the FT-101; a 12BY7 driver, and two 6JS6C finals run in parallel.

Since not all service personnel are as familiar with tubes as they are with semiconductors, we will begin by cautioning you that tubes are voltage devices, and to produce power in useful amounts they require voltages well in excess of that needed for solid state devices. Use care, or you will quickly develop "serviceman's elbow", a malady known well to old timers who often developed a colorful vocabulary to go with the sore elbow that develops when your arm jerks back from the +600 volts right into some nearby immovable object. While seldom fatal, it is not an experience one knowingly encourages.

The three tubes are all biased to operate Class "B", providing a linear reproduction of the RF applied to the grids, through utilization of the parallel tuned plate circuit to restore the missing half cycle of each voltage excursion.

Excessive bias will move the operating point into Class "C", and produce distortion, generally referred to as "flat topping" and caused by the RF peaks being clipped, thus producing undesired combinations of frequencies.

Insufficient bias will not cause distortion, but will produce excessive heat, since the tube approaches a Class "A" condition, and it's sensitivity increases to dangerous levels - in some cases, the tube will "take off", go into Class "C" and act as a high powered oscillator, producing quantities of unwanted RF on unplanned frequencies, so make every effort to avoid losing bias when servicing.

Make an initial check of the voltages according to the data provided on page 4-15. If everything is normal, but you still have trouble, then read on.

LOW POWER OUTPUT ON 10 METERS is frequently caused by a short between the two white leads running from the tank coil to switch S1m, which has the effect of shorting out the 10m and 11m sections. If you have normal output on all bands but 10 and 11m, check this out first. This short results from operating into a high SWR on either 10m or 11m.

LOW POWER OUTPUT ON ALL BANDS usually indicates either a driver problem, or weak output tubes. Not all tubes will work in FT-101's, due to the variations in internal geometry of the elements that occur between different manufacturers. This in turn results in grid-plate capacitances that deviate so widely from the design value that neutralization becomes impossible. And un-neutralized finals will generate spurious signals, overheat, and fail rapidly.

For this reason, use TOSHIBA finals. Other (USA) brands just don't work properly, and are very subject to premature mechanical failure.

Driver tubes (12BY7) are less tricky, but if you use G.E. tubes, reduce the neutralizing capacitor (C-123) to 3pf, or increase it to 5pf when using RCA tubes.

Very few subtle problems arise in the driver/final area other than those noted. Usually all other problems are easily and quickly located, since they normally are accompanied by flashes, crackling or smoke, infallible indications of something amiss. - HI.

#### FINAL AMPLIFIER NEUTRALIZATION

The final compartment cover must be in place to supply the RF shielding required during the neutralization procedure.

↑  
**CAUTION**

HIGH VOLTAGES ARE PRESENT ON UNDERSIDE OF CHASSIS AND INSIDE OF FINAL COMPARTMENT. USE GREAT CARE WHILE MAKING ADJUSTMENTS WITH WIRING EXPOSED.

1. Connect a dummy load to antenna, and set meter to IC.
2. Locate TC27 the neutralization variable capacitor shaft on the underside of the chassis near the driver stage band switch wafer, in the final amplifier section.
3. Check final amplifier idle current in USB or LSB position and adjust as described before.
4. Tune up the transceiver at 29 MHz, 10B or 10C band with MODE switch at TUNE position, and advance the CARRIER control until meter IC reads 200ma.
5. Rotate PLATE tuning control and observe dip as indicated on the meter. If the dip is not prominent, reduce the loading control slightly for better indication. As the PLATE control is rotated the meter should rise equally and smoothly on either side of maximum dip indication.
6. Determine which side of the dip rises abruptly. Set PLATE control slightly to this side of dip keeping the meter reading below 100ma.
7. Using nonmetallic tuning wand, rotate neutralization capacitor shaft very slightly in the direction which reduces the current shown on the meter. Repeat steps 6 and 7 until the meter indicates a smooth and equal rise on either side of the maximum dip point.

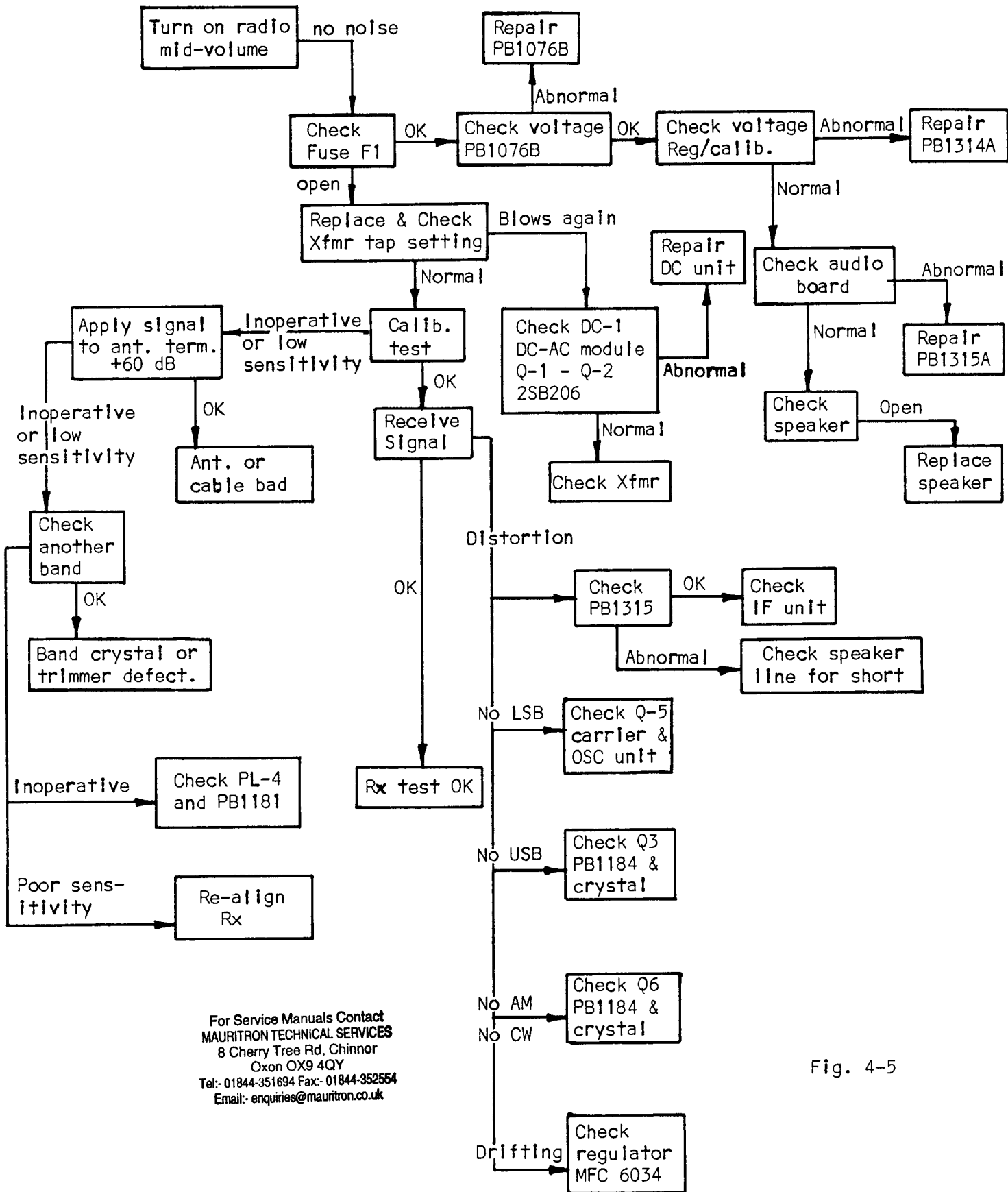

For Service Manuals Contact  
 MAURITRON TECHNICAL SERVICES  
 8 Cherry Tree Rd, Chinnor  
 Oxon OX9 4QY  
 Tel:- 01844-351694 Fax:- 01844-352554  
 Email:- enquiries@mauritron.co.uk

Fig. 4-5

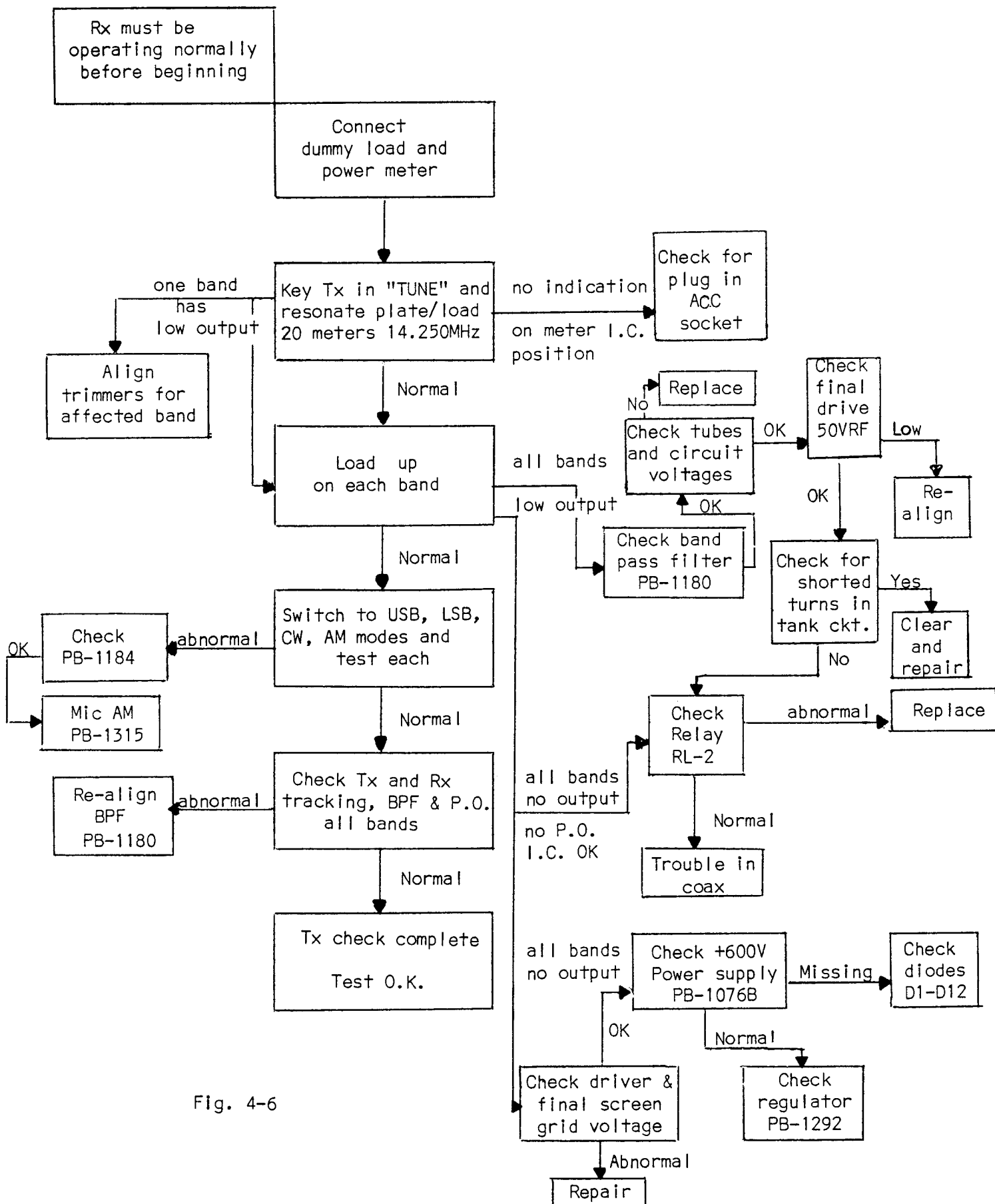

Fig. 4-6

# FT-101

## VOLTAGE CHART

MJ PIN	D.C. VOLTAGE												R.F. VOLTAGE											
	1		2		3		4		5		6		1		2		3		4		5		6	
	R	T	R	T	R	T	R	T	R	T	R	T	R	T	R	T	R	T	R	T	R	T	R	T
1	E	E	E	E	E	E	E	E	E	E	E	E	E	E	E	E	E	E	E	E	E	E	E	E
2	E	E	E	E	E	E	E	E	E	E	E	E	E	E	E	E	E	E	E	E	E	E	E	E
3	6.0	6.0	0	0	13.0	12.5	0	0	0.7	0.7	-18	0	3	3	3180	79DB								
4	0.5	0.5	E	E	0	0	0	0	8.5	8.5	-20	-3.5	2	2	E	E								
5	5.5	5.5	8.5	8.5	0	0	0	0	6.0	6.0	-150	-140					0.6	0						
6	6.0	6.0	E	E	0	0	E	E	0	0	170	170							E	E				
7	E	E	13.0	12.5	E	E	0	0	E	E	2.7	2.7	E	E										
8	0	0	E	E	0	0	0	0	0	0	0.6	2.7	14250	46DB										
9	8.0	13.0	12.0	0	9.0	9.0	9.0	9.0	0	0	12.5	0												
10	0	11.5	E	E	6.5	0.35	1.5	1.5	13.0	12.5	0	11.5					3180	70DB	0.01					
11	13.0	12.5	0	0	13.0	12.5	E	E	0	0	2.5	2.5	14250	46DB	2	0.08	0.08		E	E				
12	12.5	0	E	E	0.7	0.7	11.0	10.5	6.6	0.3	13.5	13.0												0.06
13	12.0	0	0	11.5	8.0	13.0	0	0	12.5	0	6.0	6.0			0.1									
14	13.0	12.5	E	E	E	E	6.0	6.0	12.5	0.3	13.0	12.5							E	E				
15	0	0	13.0	12.5	0	0	13.0	12.5			0	0	0.3	0.3	5720	66DB	0.4	0.06						
16	0	11.5	13.0	12.5	3.0	3.0	13.0	12.5			0	0					5720	66DB						
17	13.0	12.5	E	E	0	0	0	0			0	0	5720	66DB	0.4	E	E	0.03						
18	E	E	E	E	0	0	E	E			E	E	E	E	E	E			E	E				E
19					13.0	12.5	E	E																
20					12.5	0	E	E																
21					6.0	6.0	E	E																
22					E	E	0	0											E	E				

MODE: USB, BAND: 20M, R: RECEIVE, T: TRANSMIT  
 VALUES WITHOUT ANY UNIT ARE IN VOLTS R.M.S.  
 VALUES WITH DB ARE SIGNAL GENERATOR OUTPUT LEVELS TO PRODUCE S-9.  
 VALUES GIVEN UNDER THE COLUMN T ARE SIGNAL LEVELS TO PRODUCE 100W OUTPUT POWER MODULATED BY 1KHZ MIC INPUT.

Fig. 4-7

VALUES ARE IN VOLTS D.C.  
 R: RECEIVE, T: TRANSMIT



# FT-101

## RESISTANCE CHART

MJ NO. PINNO.	1	2	3	4	5	6
1	E	E	E	E	E	E
2	E	E	150	E	0	10K
3	300	0	10	0		4K
4	3K	E	$\infty$		10K	10K
5	300	10K	350	$\infty$	200	30K
6	200	E	1K	E	5	50K
7	E	10	E	0	E	3K
8	0	E	0	1K	5K	6K
9	3K	200	10K	10K	1K	200
10		E	3K	50K	10	0
11	20	$\infty$	10	E	50K	3K
12	200	E	1K	100	3K	10
13	200	0	3	$\infty$	200	200
14	10	E	E	200	500	10
15	0	100	0	10	—	50K
16	0	100	$\infty$	10	—	0
17	100	E	$\infty$		—	$\infty$
18	E	E	0	E	—	E
19	—	—	10	E	—	—
20	—	—	200	—	—	—
21	—	—	200	—	—	—
22	—	—	E	—	—	—

VALUES ARE IN OHMS.

Fig. 4-8

# FT-101-B & FT-101-E/EE/EX

## VOLTAGE CHART

MJ PIN	D.C. VOLTAGE														R.F. VOLTAGE													
	1		2		3		4		5		6		7		1		2		3		4		5		6		7	
	R	T	R	T	R	T	R	T	R	T	R	T	R	T	R	T	R	T	R	T	R	T	R	T	R	T	R	T
1	E	E	E	E	E	E	E	E	E	E	E	E	E	E	E	E	E	E	E	E	E	E	E	E	E	E	E	
2	E	E	E	E	E	E	E	E	E	E	E	E	E	E	E	E	E	E	E	E	E	E	E	E	E	E	E	
3	6.0	6.0	0	0	13.0	12.5	0	0	0.7	0.7	-18	0	E	E	* 3	* 3	3180KHz 77dB	0	—	—	—	—	—	—	—	—	—	
4	0.5	0.5	E	E	0	0	0	0	8.5	8.5	-20	-3.5	0	0	* 2	* 2	E	E	—	—	—	—	—	—	—	—	—	
5	5.5	5.5	13.0	12.5	0	0	0	0	6.0	6.0	-150	-140	0	13.0	—	—	—	0.03	0.08	0	—	—	—	—	—	—	—	
6	6.0	6.0	E	E	0	0	E	E	0	0	170	170	0	0	—	—	E	E	—	—	E	E	0.8	0.8	—	—	—	
7	E	E	13.0	12.5	E	E	0	0	E	E	0	0	13.5	12.5	E	E	—	—	E	E	—	—	—	—	—	—	—	
8	0	0	E	E	0	11.5	0	0	0	0	0.6	2.7	1.0	1.0	14MHz 46dB	—	E	E	—	—	—	—	—	—	—	—	—	
9	8.0	13.0	12.0	0	9.0	9.0	9.0	9.0	0	0	12.5	0	E	E	—	—	—	—	—	—	—	—	—	—	—	—	—	
10	0	11.5	E	E	6.5	0.35	-18	0	13.0	12.5	0	11.5	E	E	—	—	E	E	—	—	—	—	—	—	—	—	—	
11	13.0	12.5	0	0	13.0	12.5	E	E	0	0	3.5	3.5	—	—	14MHz 60dB	—	2	0.12	0.12	—	—	E	E	—	—	—	—	
12	12.5	0	E	E	0.7	0.7	9.0	9.0	6.6	0.3	13.5	13.0	—	—	—	—	—	—	—	—	—	—	—	—	—	—	—	
13	12.0	0	0	11.5	8.0	13.0	0	0	12.5	0	6.0	6.0	—	—	—	—	0.15	—	—	—	—	—	—	—	—	—	—	
14	13.0	12.5	E	E	E	E	6.0	6.0	12.5	0.3	13.0	12.5	—	—	—	—	—	—	—	—	—	—	—	—	—	—	—	
15	0	0	13.0	12.5	0	0	13.0	12.5	—	—	0	0	—	—	—	—	5720KHz 55dB	0.5	0.5	3180KHz 94dB	0.06	—	—	—	—	—	—	
16	0	11.5	13.0	0	0	0	13.0	12.5	—	—	0	0	—	—	—	—	5720KHz 73dB	0.15	—	—	—	—	—	—	—	—	—	
17	13.0	12.5	E	E	0	0	0	0	—	—	0	0	—	—	5720KHz 55dB	—	0.5	E	E	3180KHz 83dB	0.15	—	—	—	—	—	—	
18	E	E	E	E	0	0	E	E	—	—	E	E	—	—	—	—	E	E	E	—	—	E	E	—	—	—	—	
19	—	—	—	—	13.0	12.5	0	0	—	—	—	—	—	—	—	—	—	—	—	—	—	—	—	—	—	—	—	
20	—	—	—	—	0	0	E	E	—	—	—	—	—	—	—	—	—	—	—	—	—	—	—	—	—	—	—	
21	—	—	—	—	0	0	E	E	—	—	—	—	—	—	—	—	—	—	—	—	—	—	—	—	—	—	—	
22	—	—	—	—	E	E	0	0	—	—	—	—	—	—	—	—	—	—	—	—	—	—	—	—	—	—	—	

MODE: USB, BAND: 20M, R: RECEIVE, T: TRANSMIT  
 VALUES WITHOUT ANY UNIT ARE IN VOLTS R.M.S.  
 VALUES WITH DB ARE SIGNAL GENERATOR OUTPUT LEVELS TO  
 PRODUCE S-9.  
 VALUES GIVEN UNDER THE COLUMN T ARE SIGNAL LEVELS TO  
 PRODUCE 100W OUTPUT POWER MODULATED BY 1KHz MC INPUT.

Fig. 4-9

VALUES ARE IN VOLTS D.C.  
 R: RECEIVE, T: TRANSMIT

# FT-101-B & FT-101-E/EE/EX

## RESISTANCE CHART

MJ PINNO. \ NO.	1	2	3	4	5	6	7
1	E	E	E	E	E	E	∞
2	E	E	15 0	30K	0	10K	E
3	300	0	10	0	∞	4K	E
4	3K	E	∞	※	10 K	10K	0
5	300	∞	0	∞	200	30K	0
6	200	E	1K	E	5	50K	0
7	E	10	E	0	E	3K	10
8	0	E	0	1K	5K	6K	100K
9	2.5K	12 0	10K	10 K	1K	120	E
10	※	E	3K	50K	10	0	E
11	100	∞	10	E	1M	3K	—
12	120	E	1K	50K	3K	10	—
13	120	0	3K	∞	1.2K	200	—
14	10	E	E	200	700	10	—
15	0	10 0	∞	10	—	50K	—
16	0	10 0	∞	10	—	0	—
17	100	E	∞	※	—	∞	—
18	E	E	∞	∞	—	E	—
19	—	—	10	※	—	—	—
20	—	—	120	E	—	—	—
21	—	—	200	E	—	—	—
22	—	—	E	※	—	—	—

VALUES ARE IN OHMS.

Fig. 4-10

VACUUM TUBE

		1	2	3	4	5	6	7	8	9	10	11	12	P
V 1	R	E	-20	E	AC 12.6	E	AC 6.3	340	260	E	-	-	-	-
	T	E	-3.6	E	AC 12.6	E	AC 6.3	270	220	E	-	-	-	-
V 2	R	AC 12.6	0	160	E	-63	160	0	E	-63	E	160	AC 6.3	650
	T	AC 12.6	0.03	160	E	-50	160	0.03	E	-50	E	160	AC 6.3	570
V 3	R	AC 6.3	0	160	E	-63	E	E	E	-63	E	160	E	650
	T	AC 6.3	0.03	160	E	-50	E	E	E	-50	E	160	E	570

VFO Unit

	E (S)		C (D)		B (G)		
	R	T	R	T	R	T	
Q 1	1.1	1.1	5.7	5.7	0	0	
Q 2	1.1	1.1	5.7	5.7	0	0	
Q 3	1.3	1.3	6	6	1.4	1.4	

High Frequency (RF) Unit (PB-1181B)

	E (S)		C (D)		B (G)		
	R	T	R	T	R	T	
Q 1	2.2	10.5	11	11	1.9 3	1.9 4.5	G 1 G 2
Q 2	1.4	10.5	11.5	11	0	7.5	
Q 3	11.5	0.85	11.5	11	5.5	1.1	
Q 4	1.2	1.2	5	5	0.85	0.85	
Q 5	1	1	5.5	5.5	1.35	1.35	

NB Unit (PB-1582)

	E (S)		C (D)		B (G)		
	R	T	R	T	R	T	
Q 1	1.35		12		1.9		
Q 2	1.4		12.5				
Q 3	NB:ON 0.95	NB:OFF 0.78	12.6	NB:OFF 12.2			
Q 4	0.7		11.5		G <sub>1</sub> 0.4 G <sub>2</sub> 1.45		
Q 5	0		11		NB:ON 0.2		
Q 6	0.15		0.11				NB:OFF 0
Q 7	0		NB:ON 5.5	NB:OFF 0.2	0.11		

High Frequency IF (MIX) Unit (PB-1180B)

	E (S)		C (D)		B (G)		
	R	T	R	T	R	T	
Q 1	11.5	1	11.5	11	9.5	1.5	
Q 2	1.05	10.5	10	11.5	0.9 3.6	0.85 3.4	G 1 G 2

Fig. 4-11

### Low Frequency IF Unit (PB-1183C)

	E (S)		C (D)		B (G)		
	R	T	R	T	R	T	
Q 1	2	2	11.5	11.5	0	0	
Q 2	0.55	11.5	12	11.5	1.15	12	
Q 4	0.35	0	6.5	11	0.5	0	
Q 5	0	0	6.5	11	0.35	0	

IC PIN NO.	1	2	3	4	5	6	7	8	
Q 3	R	0.6	2.5	0.4	1.8	7.5	12	6.5	0.6
	T	12	12	12	12	7.5	12	12	12

### Modulator Unit (PB-1184A)

	E (S)		C (D)		B (G)		
	R	T	R	T	R	T	
Q 1	11.5	0.9	11	11	8.5	0	
Q 2	10	0.3	11.5	11	4.5	0.65	MODE: CW
Q 3	0.45	0.45	5.5	5.5	0.95	0.95	MODE: USB
Q 4	1.2	1.2	8	8	1.8	1.8	
Q 5	0.45	0.45	5.5	5.5	0.95	0.95	MODE: LSB
Q 6	10	0.45	5.5	5.5	5	0.95	MODE: CW

### Audio Unit (PB-1315A)

	E (S)		C (D)		B (G)		
	R	T	R	T	R	T	
Q 1	2.5	2.5	5.5	5.5	0	0	
Q 2	0.6	0.6	3.2	3.2	1.1	1.1	
Q 3	2.7	2.7	9	9	3.3	3.3	
Q 5	0.35	0.35	0.5	0.5	0	0	
Q 6	E	E	11	11	0.5	0.5	S7: VOX
Q 7	0	0	8	8	0.4	0.4	MODE: CW
Q 9	0.65	0.65	3.9	3.9	0.4	0.4	

IC PIN NO.	1	2	3	4	5	6	7	
Q 4	R·T	0.7	0.1	2.8	0.1	E	0.6	1.2
Q 8	R·T	5.7	E	7	9.5	5.5	E	5.5

IC PIN NO.	8	9	10	11	12		
Q 4	R·T	3.5	0.7	6	8.2	8.2	
Q 8	R·T	10.5	11.5	—	—	—	

### RF Speech Processor Unit (Fix)

	E (S)		C (D)		B (G)		
	R	T	R	T	R	T	
Q 1	0.45	0.45	12.5	11.5	0	0	PROCESS: OFF
	0.45	0.45	12.5	11.5	0	0	PROCESS: ON
Q 3	1.35	1.35	12.5	11.5	0	0	" OFF
	1.35	1.35	12.5	11.5	0	0	" ON
Q 4	2.3	1.8	12.5	11.5	0	0	" OFF
	2.3	2.3	12.5	11.5	0.6	0.6	" ON
Q 5	0	0	0	0	0.6	0.6	" OFF
	0	0	0	0	0.6	0.6	" ON
Q 6	12.0	12.0	12.5	12.5	8.3	8.3	" OFF
	1.75	1.75	11.5	11.5	0	0	" ON
Q 7	0.44	0.44	5.4	5.4	0	0	S4: CH1 CH2

IC PIN NO.	1	2	3	4	5		
Q 2	R	12.5	12.5	11.5	12.5	12.5	PROCESS: OFF
	T	11.5	11.5	10.5	11.5	11.5	
	R	12.5	12.5	11.5	12.5	12.5	PROCESS: ON
	T	2.05	2.2	0.7	11	11	

Fig. 4-12

# BOARD LOCATIONS - PARTS LOCATIONS

## SECTION 5

CONTENTS	PAGE
BOARD/MODULE COMPLEMENT . . . . .	5-1
BREAK IN POINTS OF PCBA CHANGES . . . . .	5-2
BOARD LOCATIONS . . . . .	5-3
VFO UNIT PB1056	
(A) FUNCTIONAL BLOCK DIAGRAM . . . . .	5-5
(B) SCHEMATIC . . . . .	5-6
(C) PARTS LOCATION . . . . .	5-7
MIXER UNIT PB1180/1182	
(A) FUNCTIONAL BLOCK DIAGRAM . . . . .	5-8
(B) SCHEMATIC . . . . .	5-9
(C) PARTS LOCATION . . . . .	5-10
RF UNIT PB1181	
(A) FUNCTIONAL BLOCK DIAGRAM . . . . .	5-11
(B) SCHEMATIC . . . . .	5-12
(C) PARTS LOCATION . . . . .	5-13
LOW FREQUENCY IF UNIT PB1183	
(A) FUNCTIONAL BLOCK DIAGRAM . . . . .	5-14
(B) SCHEMATIC . . . . .	5-15
(C) PARTS LOCATION . . . . .	5-16
MODULATOR UNIT PB1184	
(A) FUNCTIONAL BLOCK DIAGRAM . . . . .	5-17
(B) SCHEMATIC . . . . .	5-18
(C) PARTS LOCATION . . . . .	5-19
NOISE BLANKER PB1292	
(A) SCHEMATIC . . . . .	5-20
(B) PARTS LOCATION . . . . .	5-21
POWER REGULATOR UNIT PB1314	
(A) SCHEMATIC . . . . .	5-22
(B) PARTS LOCATION . . . . .	5-23

For Service Manuals Contact  
**MAURITRON TECHNICAL SERVICES**  
 8 Cherry Tree Rd, Chinnor  
 Oxon OX9 4QY  
 Tel:- 01844-351694 Fax:- 01844-352554  
 Email:- [enquiries@mauritron.co.uk](mailto:enquiries@mauritron.co.uk)

CONTENTS	PAGE
AUDIO UNIT PB1315	
(A) FUNCTIONAL BLOCK DIAGRAM . . . . .	5-24
(B) SCHEMATIC . . . . .	5-25
(C) PARTS LOCATION . . . . .	5-26
RF SPEECH PROCESSOR PB1494	
(A) SCHEMATIC . . . . .	5-27
(B) PARTS LOCATION . . . . .	5-28
RF SPEECH PROCESSOR PB1534	
(A) SCHEMATIC . . . . .	5-29
(B) PARTS LOCATION . . . . .	5-30
REGULATOR AND CALIBRATOR UNIT PB1547	
(A) FUNCTIONAL BLOCK DIAGRAM . . . . .	5-31
(B) SCHEMATIC . . . . .	5-32
(C) PARTS LOCATION . . . . .	5-33
NOISE BLANKER UNIT PB1582	
(A) FUNCTIONAL BLOCK DIAGRAM . . . . .	5-34
(B) SCHEMATIC . . . . .	5-35
(C) PARTS LOCATION . . . . .	5-36
MAIN CHASSIS UNITS	
(A) RF TRIMMER BOARD PB1188 . . . . .	5-37
(B) TRIMMER BOARD A, PB1187 . . . . .	5-37
(C) TRIMMER BOARD B, PB1092 . . . . .	5-37
(D) ANTENNA TRAP BOARD PB1116 . . . . .	5-37
(E) CRYSTAL BOARD PB1073 . . . . .	5-38
(F) RECTIFIER BOARD PB1076B . . . . .	5-38
(G) PB1076B PARTS LOCATION . . . . .	5-39
(H) TRAP BOARD PB1109 . . . . .	5-40
(I) COIL BOARD A PB1083 . . . . .	5-40
(J) COIL BOARD E PB1166 . . . . .	5-40
(K) DIODE SWITCH BOARD PB1186 . . . . .	5-40

BOARD/MODULE COMPLEMENT

FT-101 Version	VFO	REG	HF-IF	LO-IF	AUDIO	RF	MOD	RECT	BLANKER	PROCESS
FT-101 (Early) S/N 25,000 & down	PB1056	PB1079A	PB1084C	PB1080A	PB1081C	PB1077B	PB1078A	PB1076A	*	None
FT-101 (Late) S/N 25,001 & up	PB1056	PB1185	PB1180	PB1183	PB1189	PB1181A	PB1184	PB1076B	PB1182	None
FT-101B (Early) S/N 06000 & down	PB1056	PB1185	PB1180	PB1183B	PB1315	PB1181B	PB1184A	PB1076B	PB1292	None
FT-101B (Late) S/N 06001 & up	PB1056	PB1314A	PB1180B	PB1183B	PB1315A	PB1181B	PB1184A	PB1076B	PB1292	None
FT-101E/EE/EX (Early) S/N 15,000 & down	PB1056	PB1314A	PB1180B	PB1183B	PB1315A	PB1181B	PB1184A	PB1076B	PB1292	PB1494
FT-101E/EE/EX (Mid) S/N 15,001 - 20,500	PB1056	PB1314A	PB1180B	PB1183B	PB1315A	PB1181B	PB1184A	PB1076B	PB1292	PB1534
FT-101E/EE/EX (Late) S/N 20,5001 & up	PB1056	PB1547A	PB1180B	PB1183C	PB1315B	PB1181B	PB1184A	PB1076B	PB1582	PB1534A

For Service Manuals Contact  
**MAURITRON TECHNICAL SERVICES**  
 8 Cherry Tree Rd, Chinnor  
 Oxon OX9 4QY  
 Tel:- 01844-351694 Fax:- 01844-352554  
 Email:- enquiries@mauritron.co.uk

\* Part of PB-1080A Board



## APPROXIMATE BREAK IN POINTS OF PCBA CHANGES

A review of factory records did not disclose the precise serial number break in points, so the following data is the best that could be achieved from old records, and should be used for guidance only.

PB-1160 was used to S/N 023000 -1182 began at S/N 024000	(Fixed Oscillator)
PB-1076 and PB-1076A were used to S/N 021000 -1076B was used beginning with S/N 022000 The major change was adding more diodes and voltage equalization resistors.	(Rectifier Board)
PB-1077A from S/N 508000 to 005000 -1077B from S/N 006000 to 023000 -1077B (modified) S/N 024000 only -1181 starts with S/N 025001	(RF Amplifier)
PB-1078 used to S/N 024000 -1078A used to S/N 025000 -1184 begins with S/N 025001	(OSC/MOD Board)
PB-1080 and 1080A used in S/N 508000 to 005000 -1080A (modified) 006000 to 023000 -1080A (modified - modified) 024000 only -1183 begins with S/N 025001	(IF Amplifier)
PB-1081, 1081A, 1081B and 1081C to 024000 (STK 401 module first used with PB-1081C) -1189 begins with S/N 025001	(Audio Unit)
PB-1084 and 1084A used S/N 508000 to 005000 -1084B and 1084C 006000 to 023000 -1084C (modified) 024000 only -1180 begins with S/N 025001	(Mixer)
PB-1229 begins at S/N 028000	(AF Preamp)

The 508000 serial number was used on some very old sets, quantity unknown, but not more than three thousand (estimated).

**For Service Manuals Contact**  
**MAURITRON TECHNICAL SERVICES**  
8 Cherry Tree Rd, Chinnor  
Oxon OX9 4QY  
Tel:- 01844-351694 Fax:- 01844-352554  
Email:- enquiries@mauritron.co.uk

# BOARD LOCATIONS

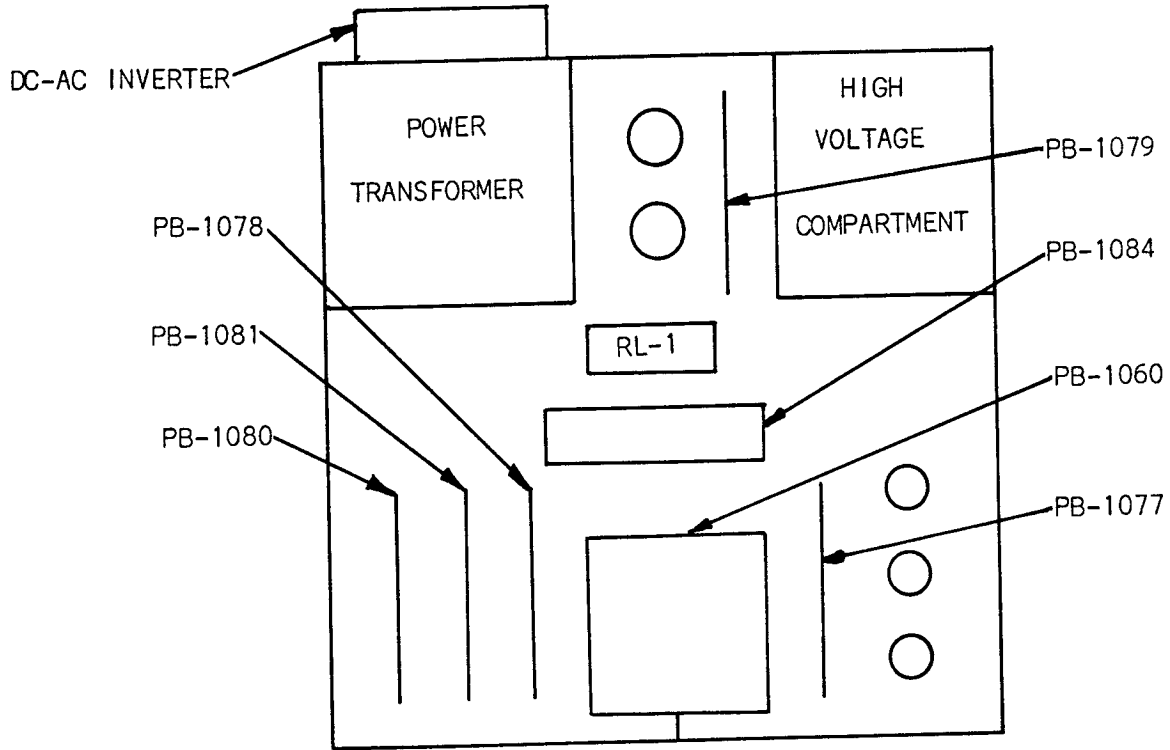

**FT-101 EARLY**  
Serial No. 025000 & down

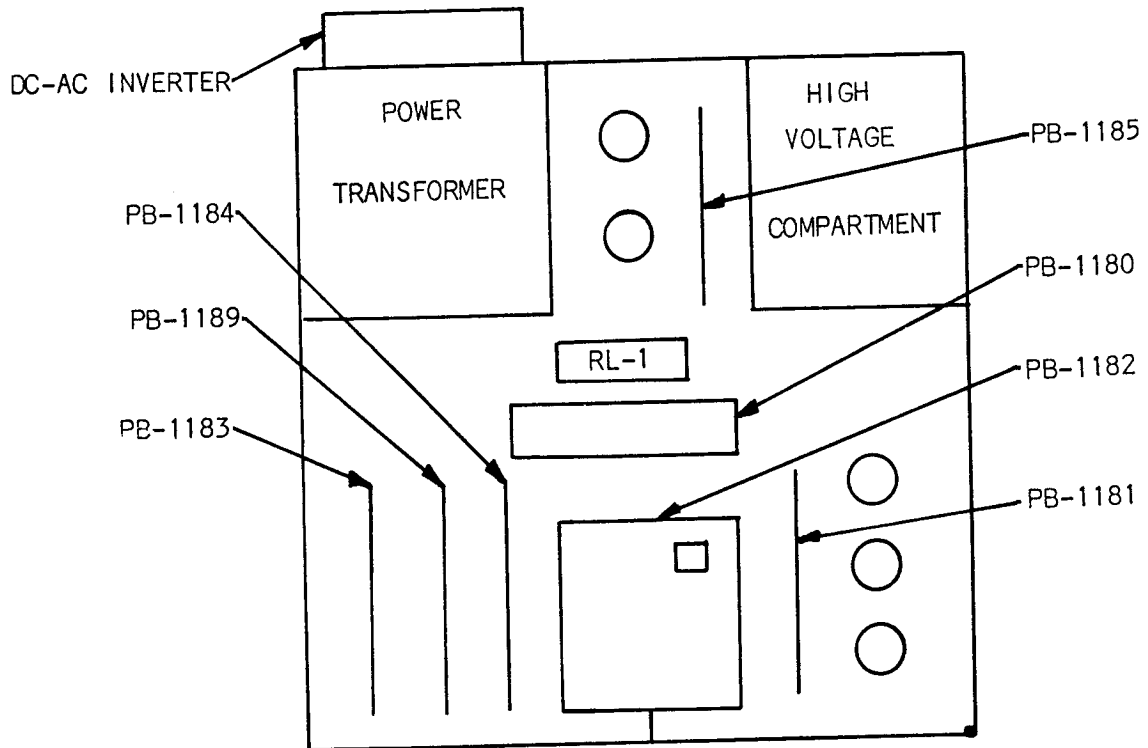

**FT-101 LATE**  
Serial No. 025001 & up

# BOARD LOCATIONS

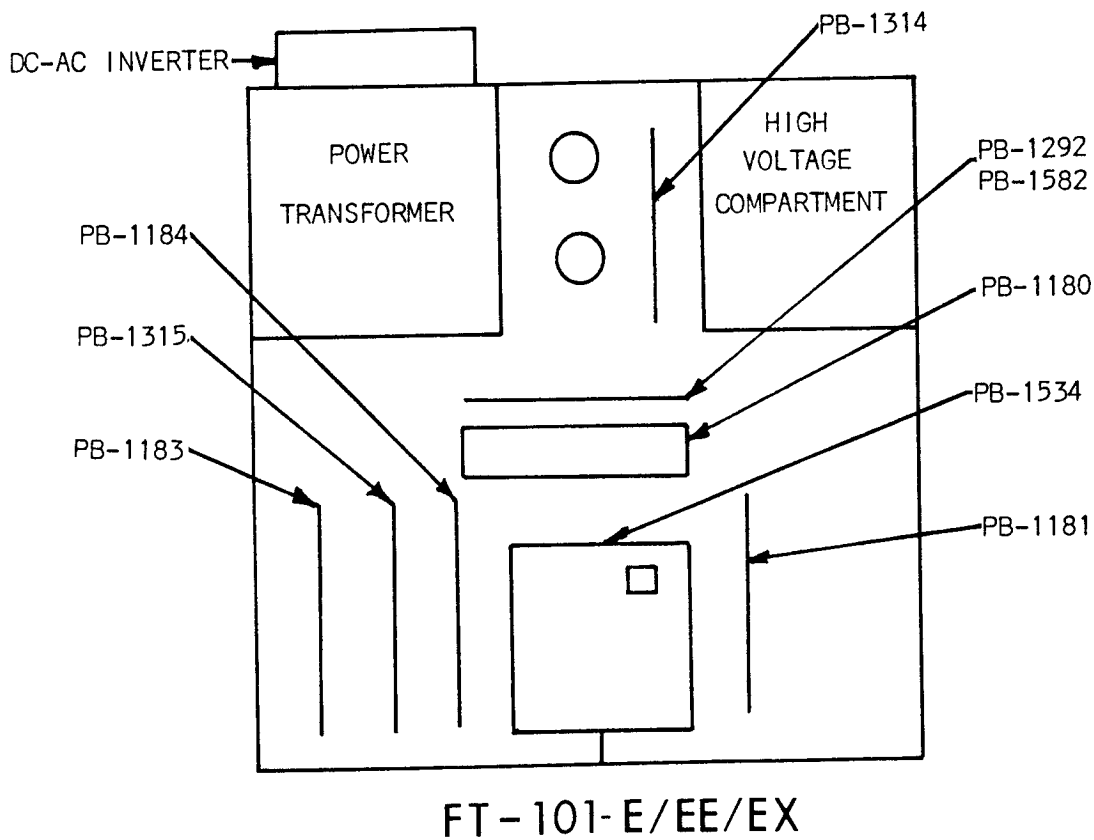
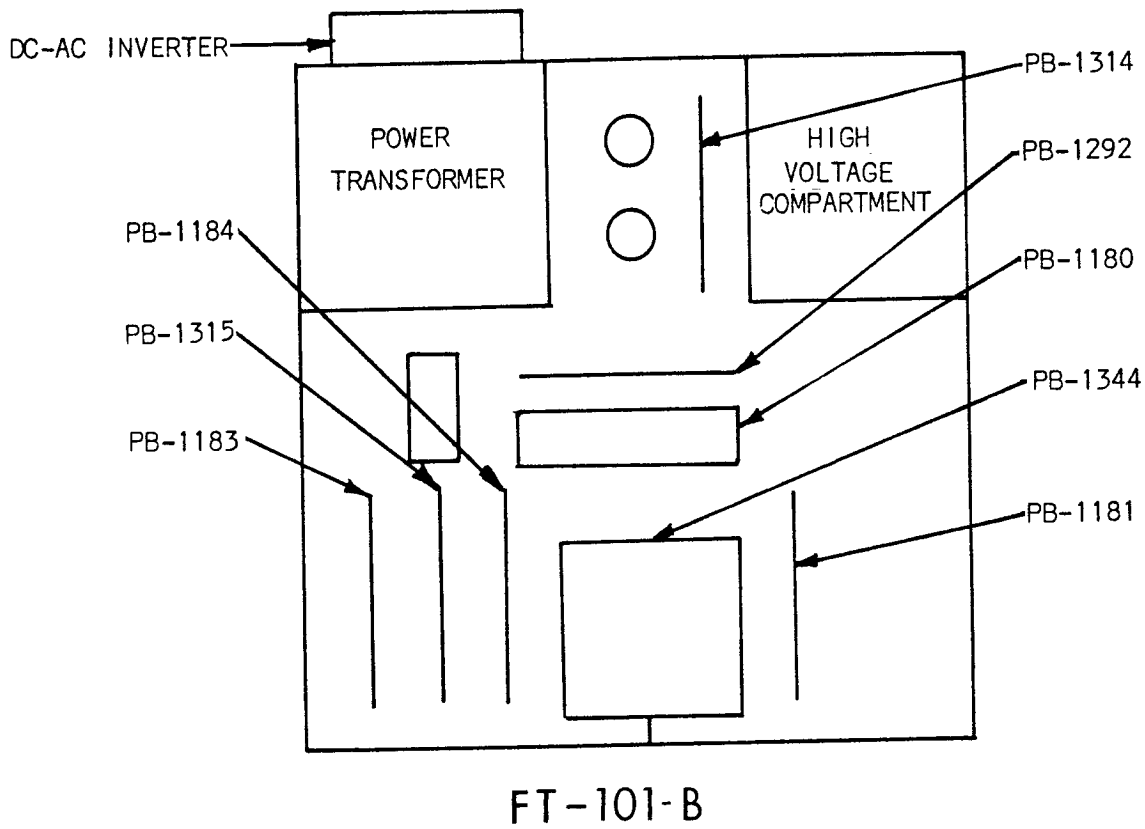

# VFO UNIT PB-1056

FUNCTIONAL BLOCK DIAGRAM

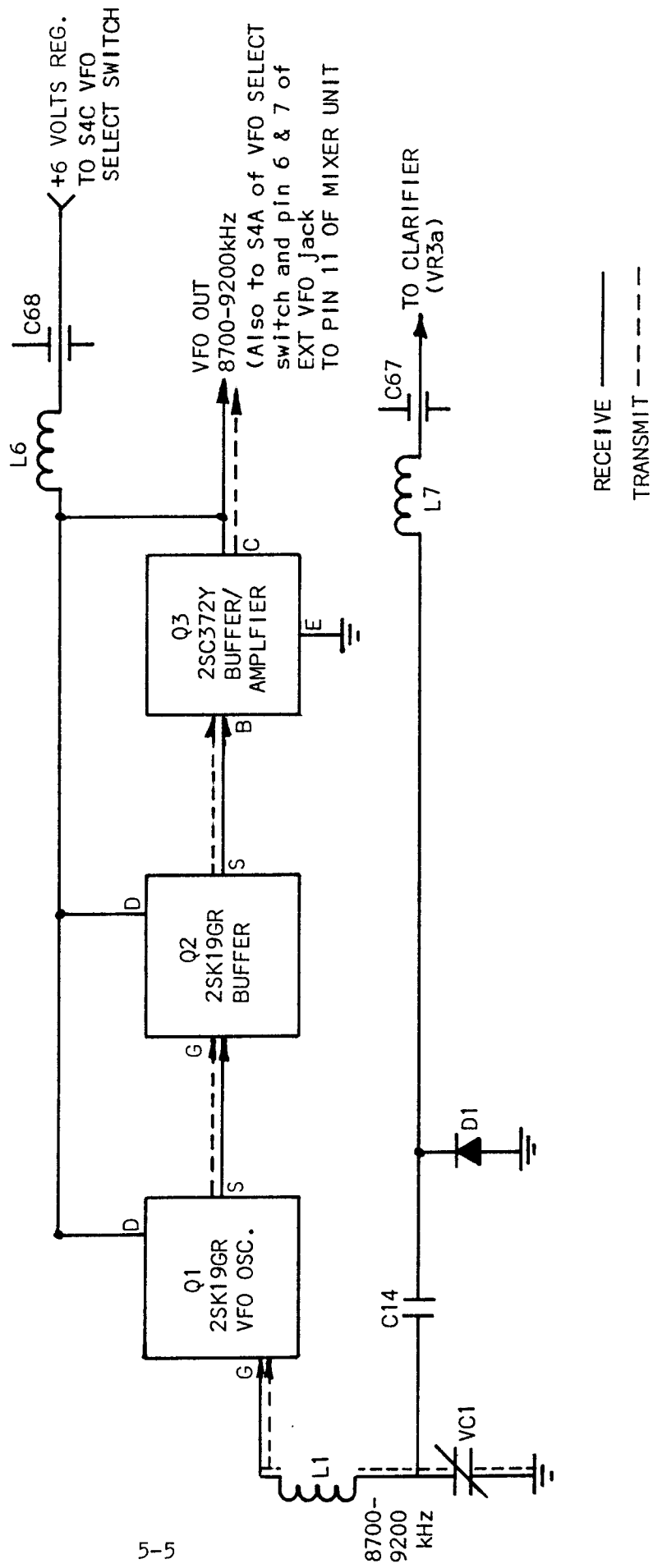

VFO UNIT

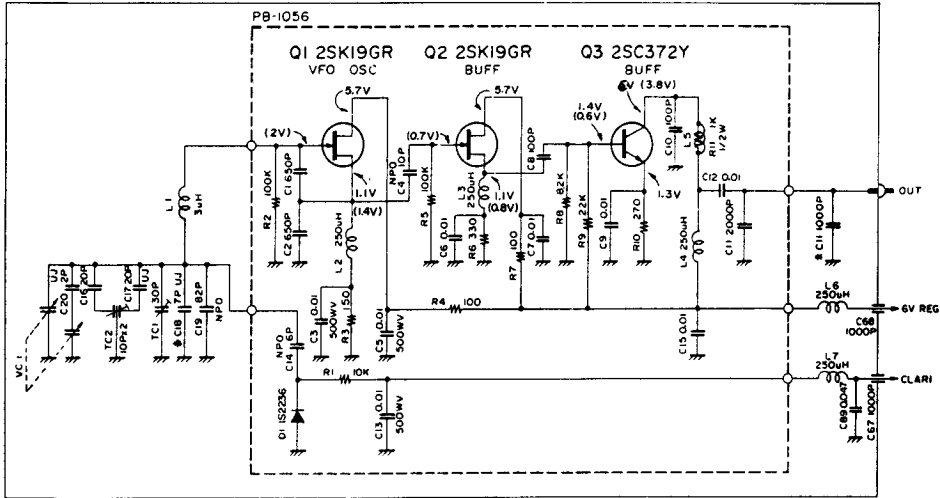

For Service Manuals Contact  
**MAURITRON TECHNICAL SERVICES**  
 8 Cherry Tree Rd, Chinnor

Oxon OX9 4QY

Tel:- 01844-351694 Fax:- 01844-352554

Email:- enquiries@mauritron.co.uk

( ) : Signal level.

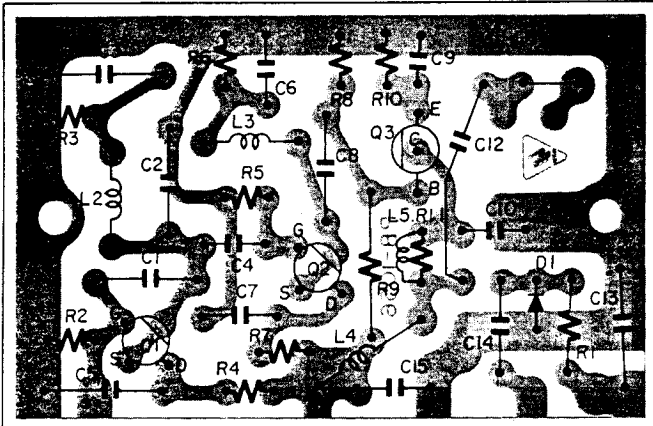

Viewed From Component Side

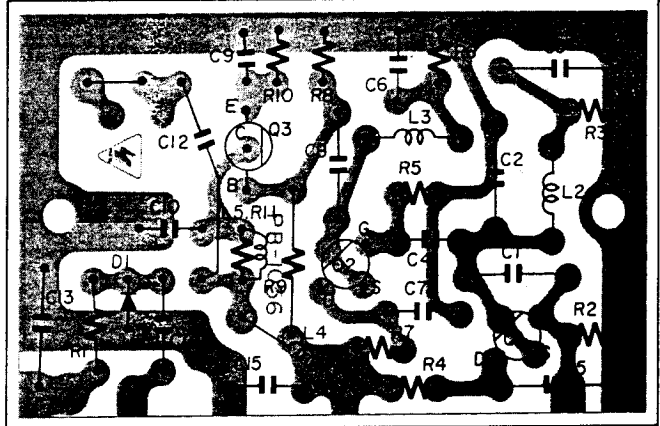

Viewed From Solder Side

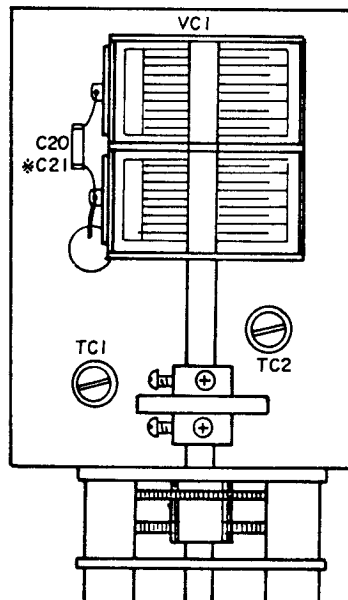
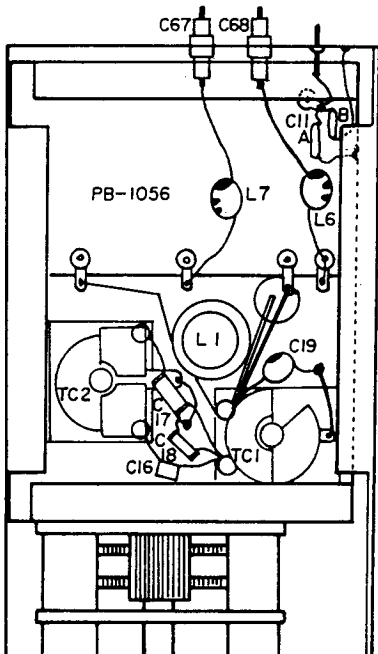

# VFO UNIT

## PB-1056

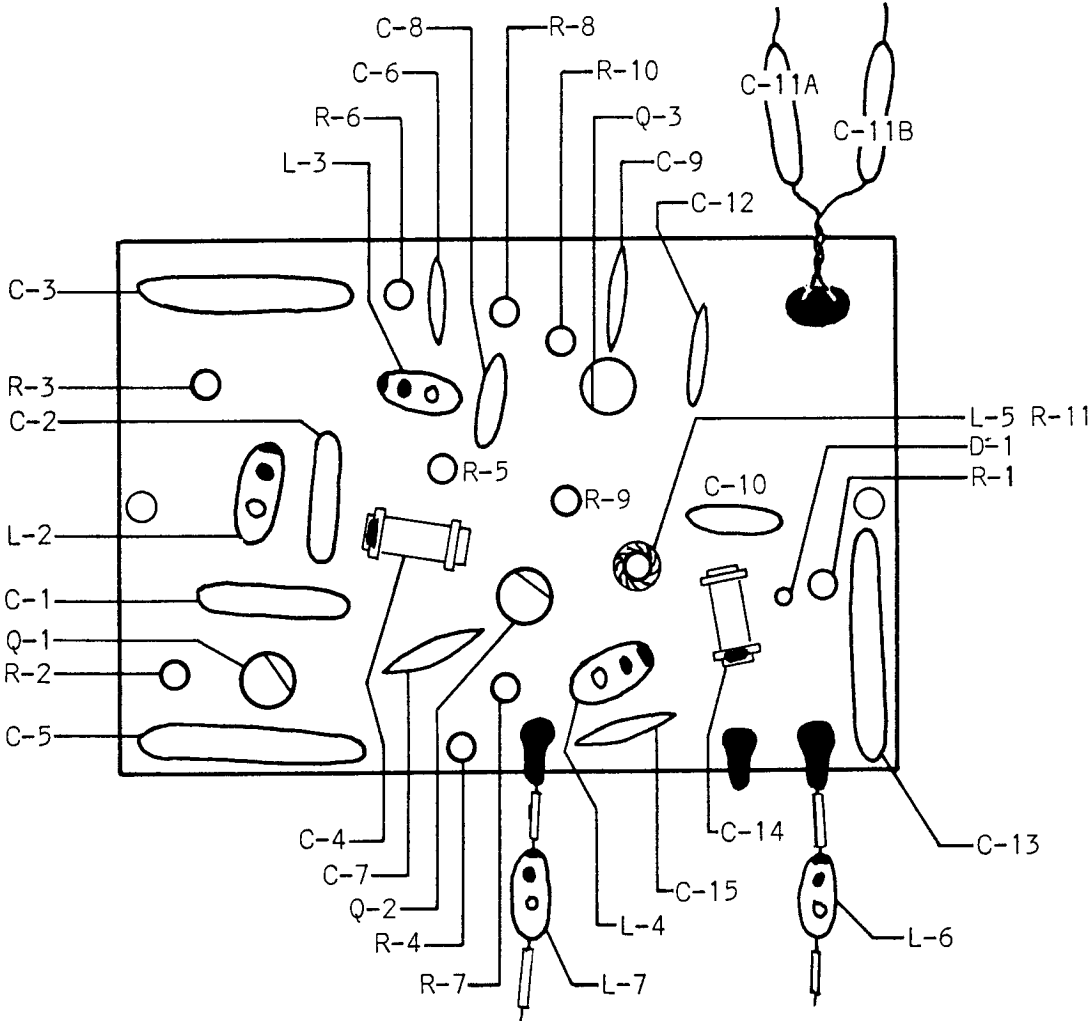

# MIXER UNIT PB-1180/1082

## FUNCTIONAL BLOCK DIAGRAM

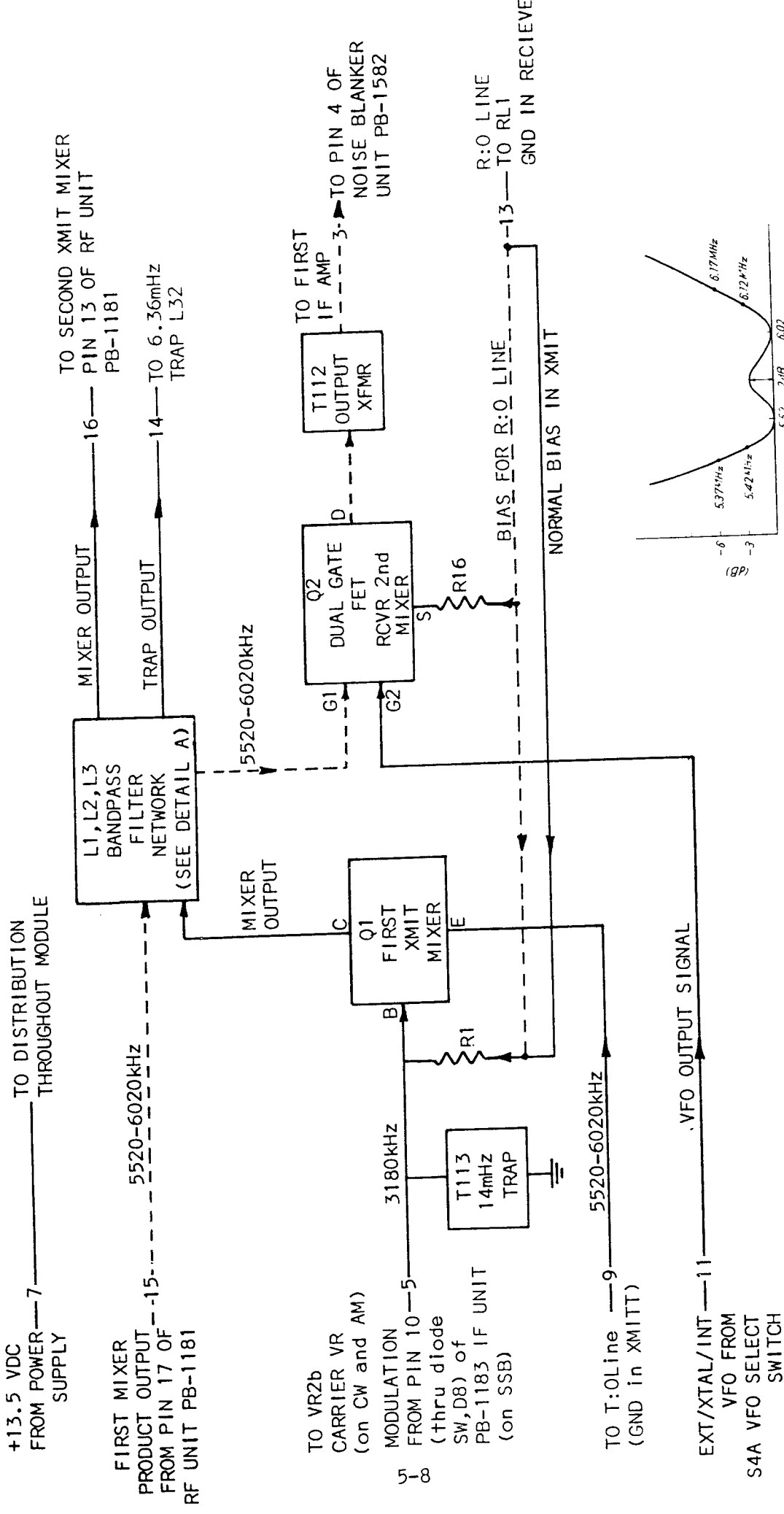

RECEIVE - - - - -  
 TRANSMIT - - - - -

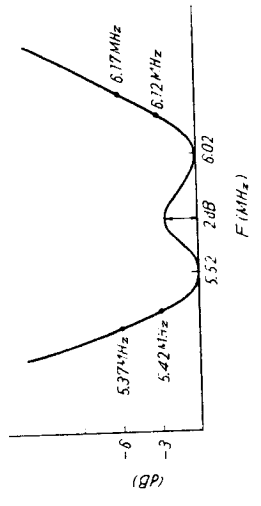

# HIGH FREQUENCY IF(MIX)UNIT PB-1180(A~Z)

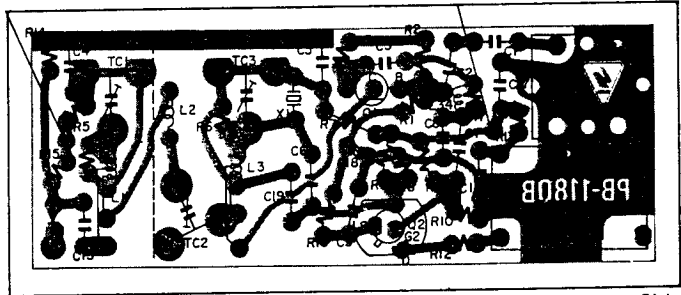
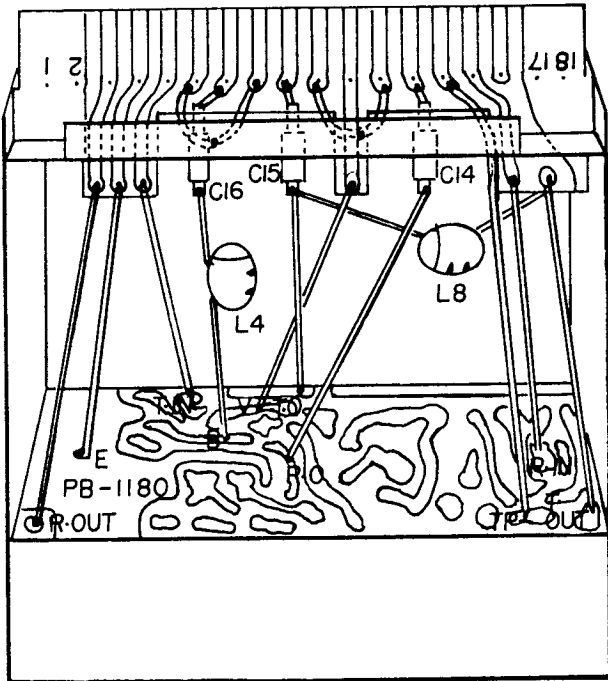
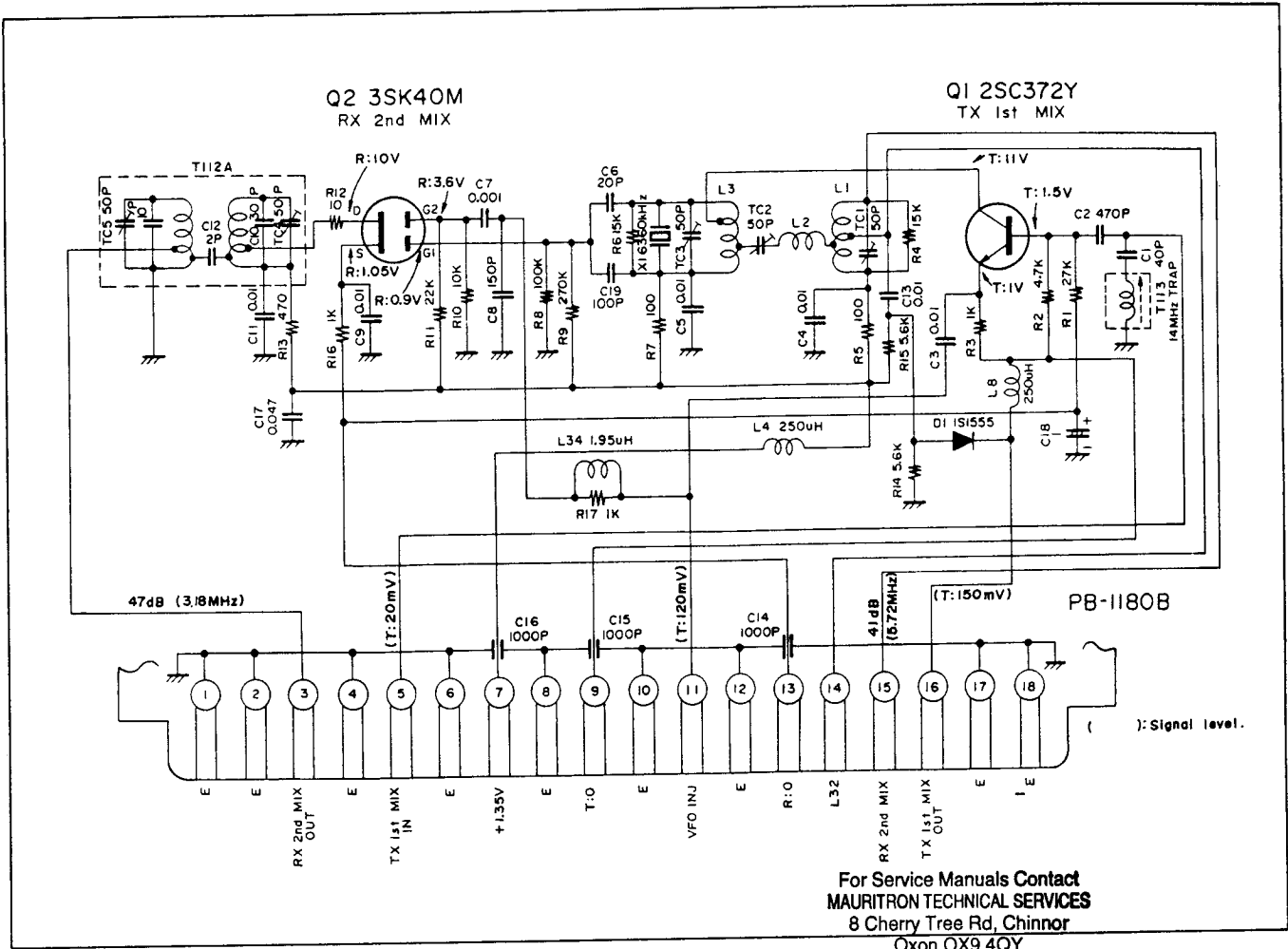

Viewed From Component Side

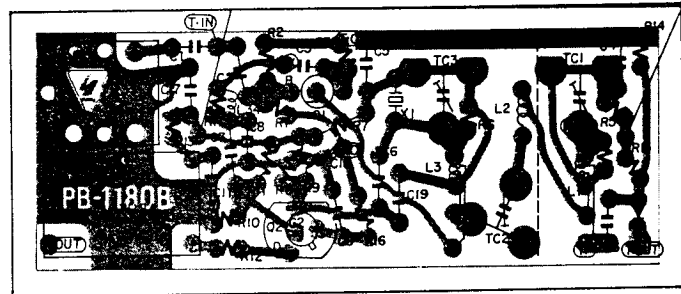

Viewed From Solder Side



# HIGH FREQUENCY IF (MIX) UNIT

## PB - 1180

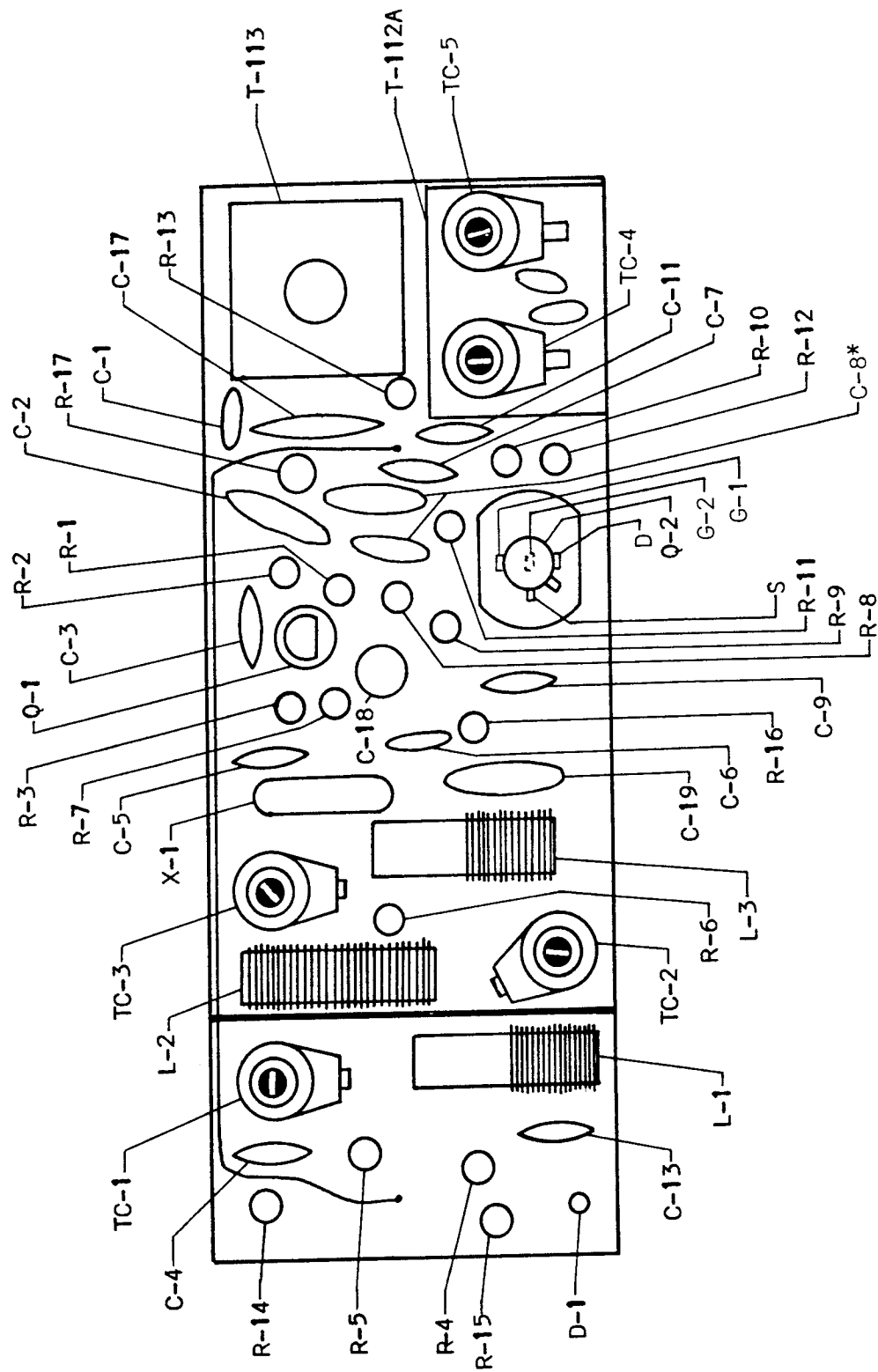

\*Capacitor C-8 is a combination of a 100pf and a 40pf capacitor

# RF UNIT PB-1181

## FUNCTIONAL BLOCK DIAGRAM

For Service Manuals Contact  
**MAURITRON TECHNICAL SERVICES**  
 8 Cherry Tree Rd, Chinnor  
 Oxon OX9 4QY  
 Tel: 01844-351694 Fax: 01844-352554  
 Email: enquiries@mauritron.co.uk

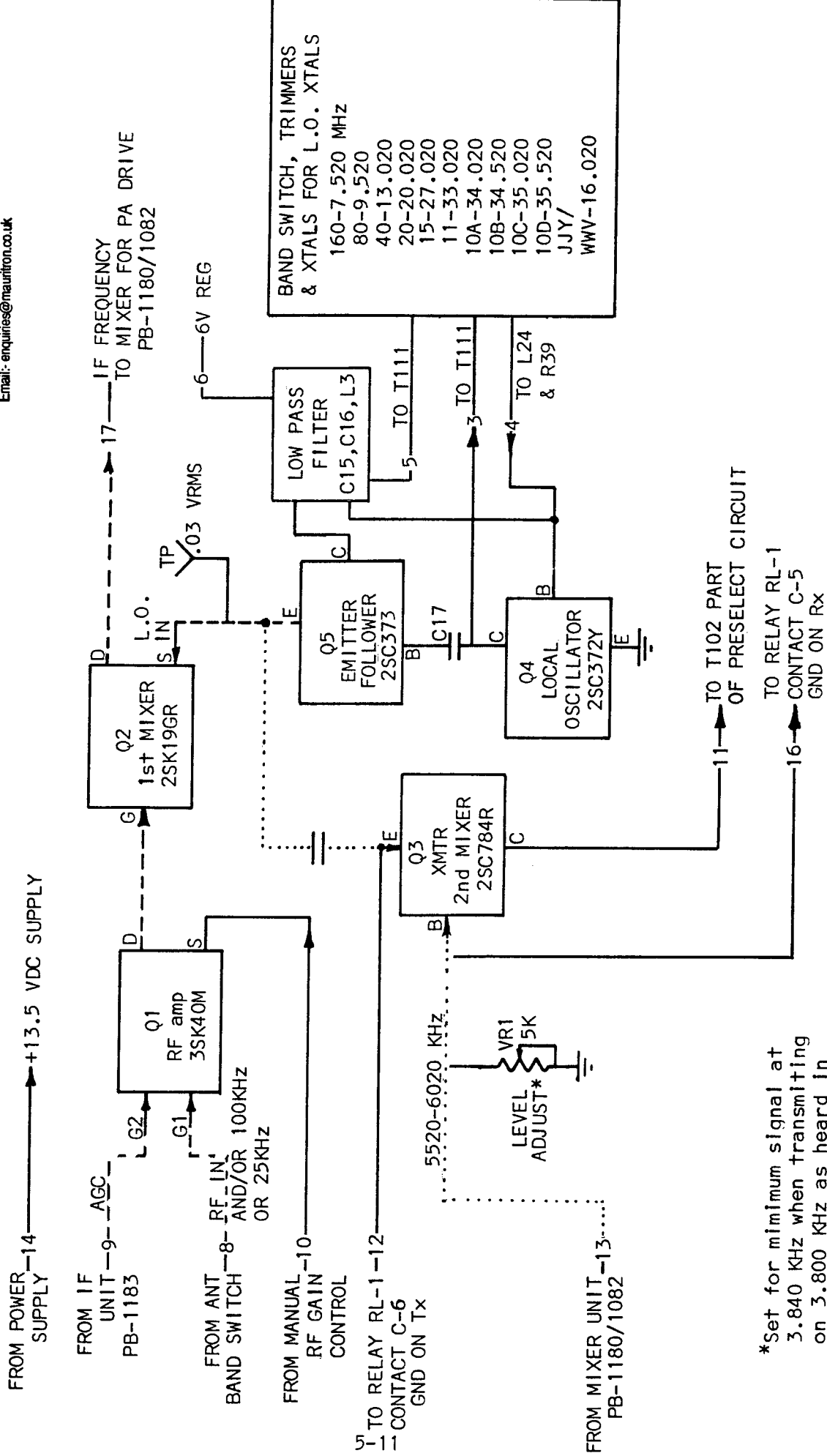

**BAND SWITCH, TRIMMERS & XTALS FOR L.O. XTALS**

160-7.520 MHz
80-9.520
40-13.020
20-20.020
15-27.020
11-33.020
10A-34.020
10B-34.520
10C-35.020
10D-35.520
JJY/
WWV-16.020

\*Set for minimum signal at 3.840 KHz when transmitting on 3.800 KHz as heard in separate receiver.

RECEIVE - - - - -  
 TRANSMIT . . . . .

# HIGH FREQUENCY(RF)UNIT PB-1181(A~Z)

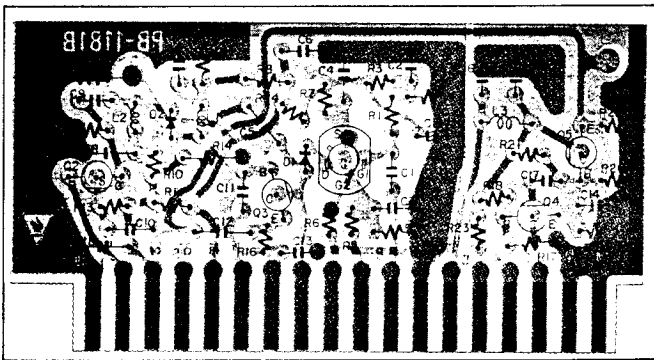
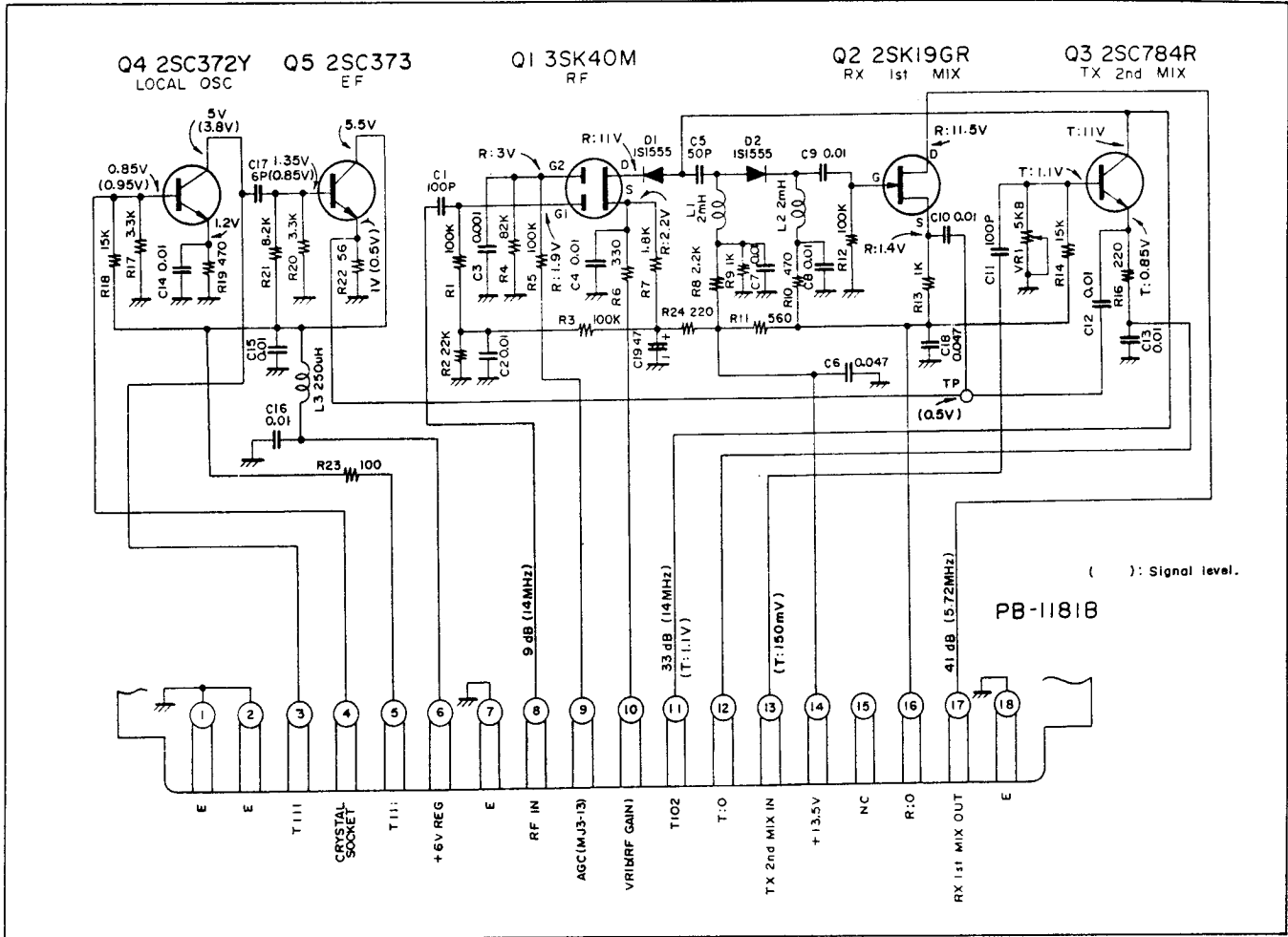

Viewed From Component Side

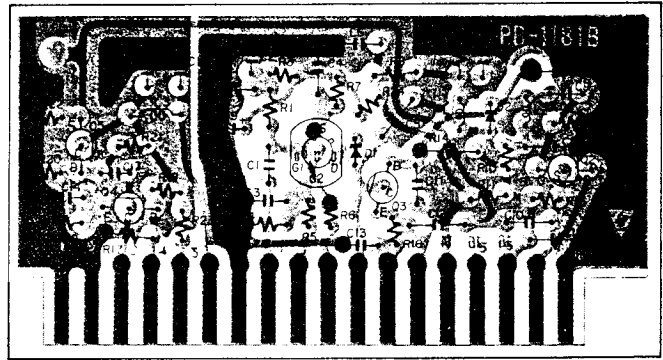

Viewed From Solder Side

# HIGH FREQUENCY (RF) UNIT

PB-1181

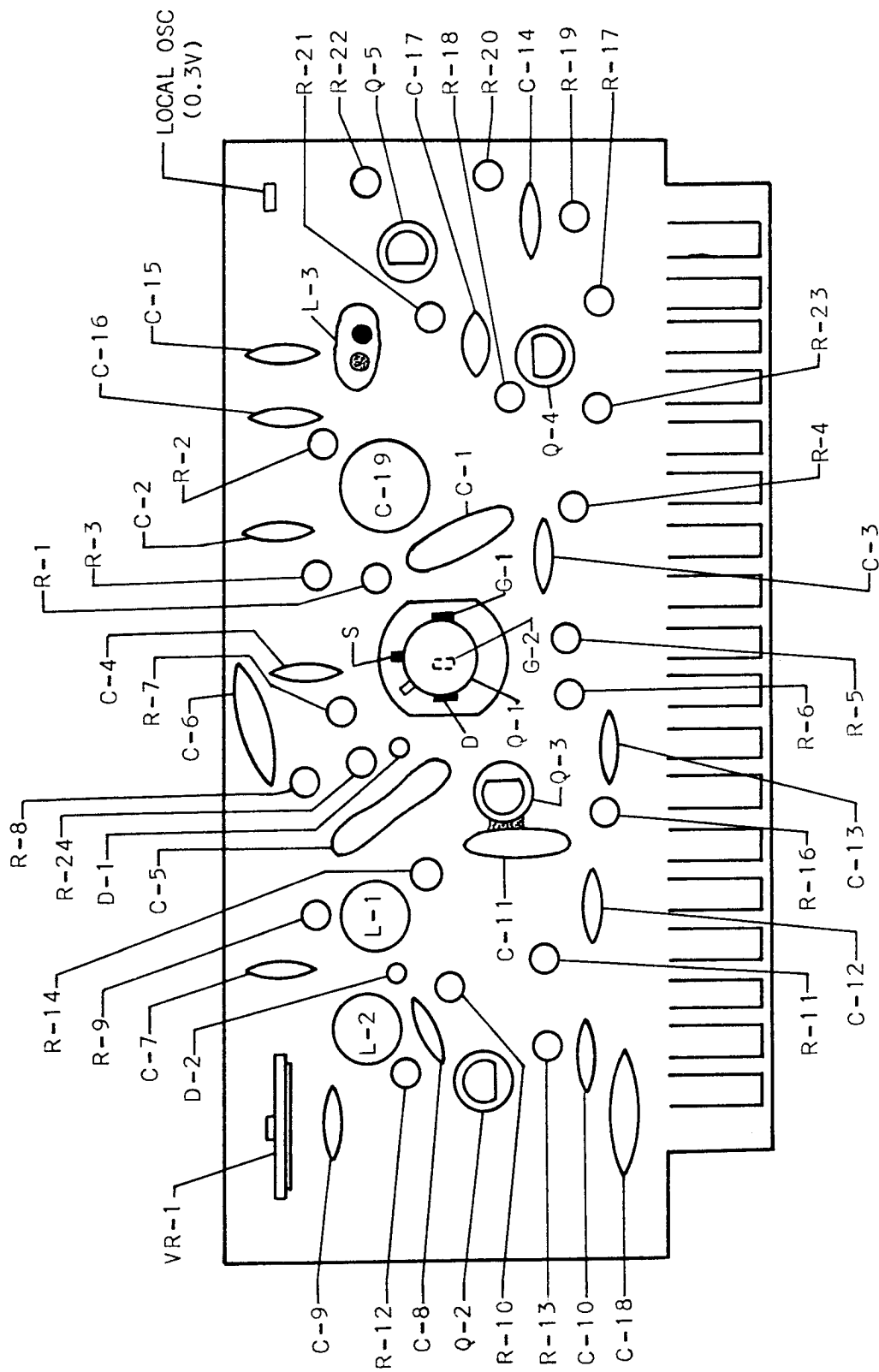

Note: There is no R-I5 resistor

# IF UNIT PB-1183

## FUNCTIONAL BLOCK DIAGRAM

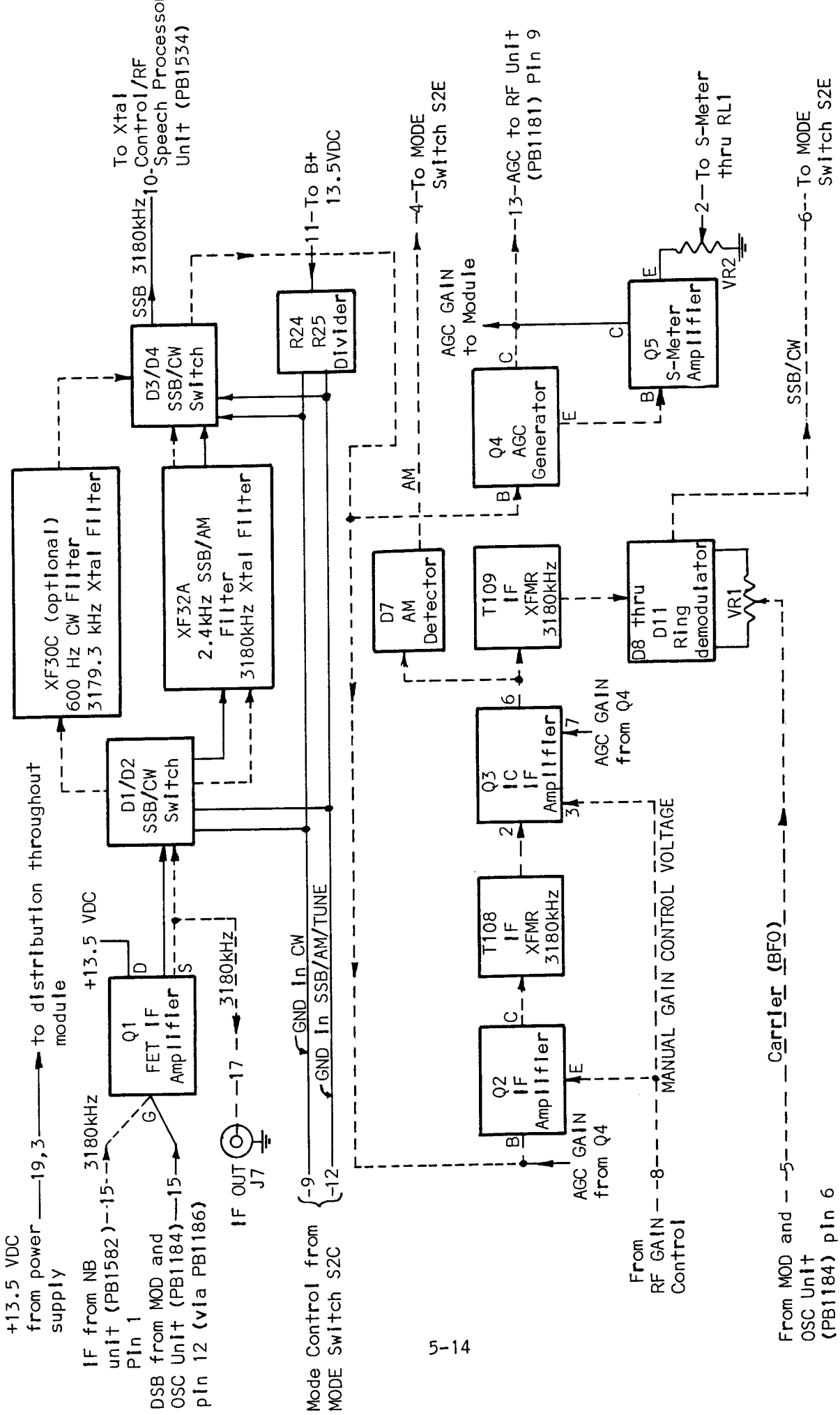

Receive Only - - - - -

# LOW FREQUENCY SET UNIT PB-1183(A~Z)

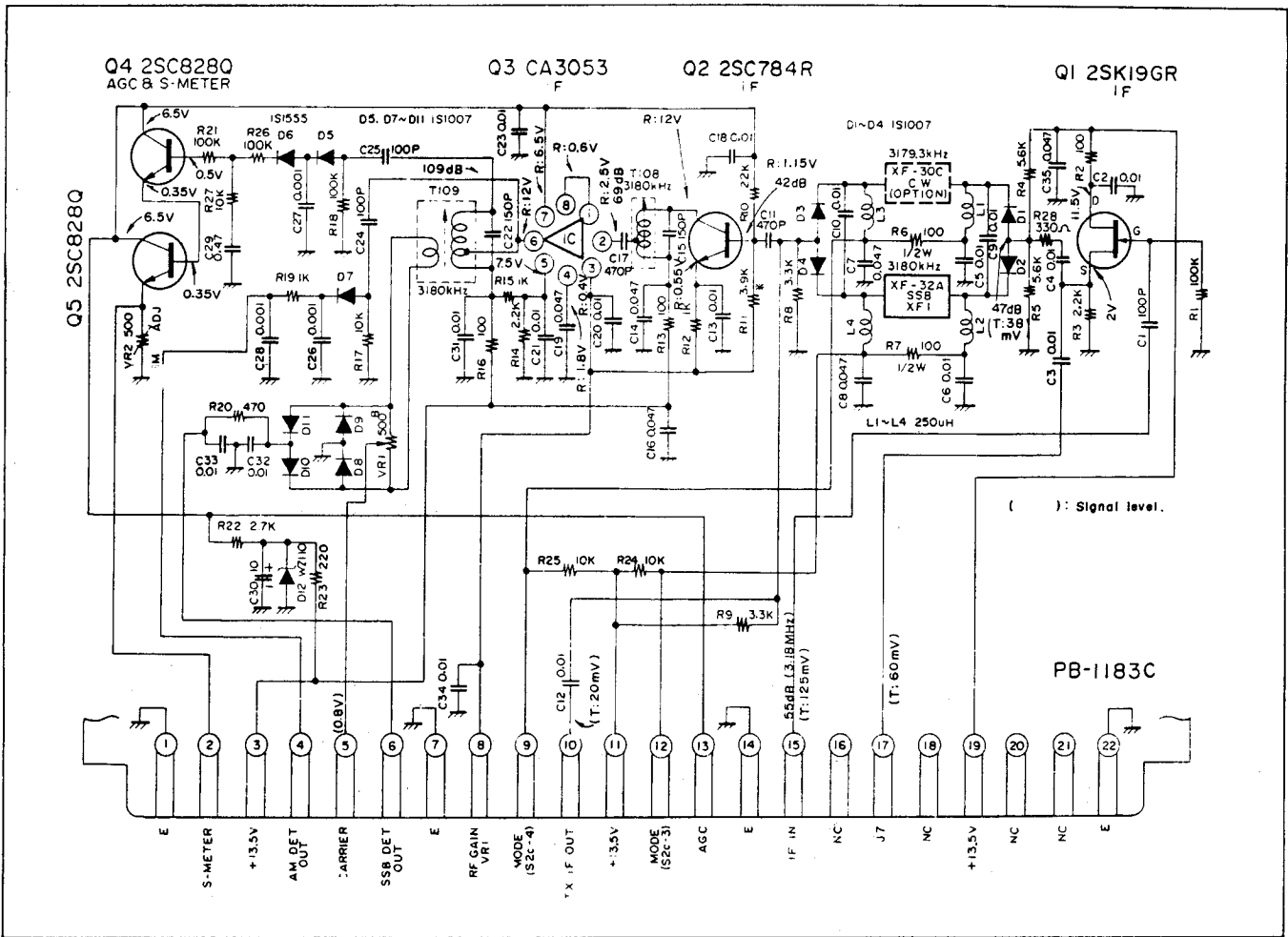

For Service Manuals Contact  
**MAURITRON TECHNICAL SERVICES**  
 8 Cherry Tree Rd, Chinnor  
 Oxon OX9 4QY  
 Tel:- 01844-351694 Fax:- 01844-352554  
 Email:- enquiries@mauritron.co.uk

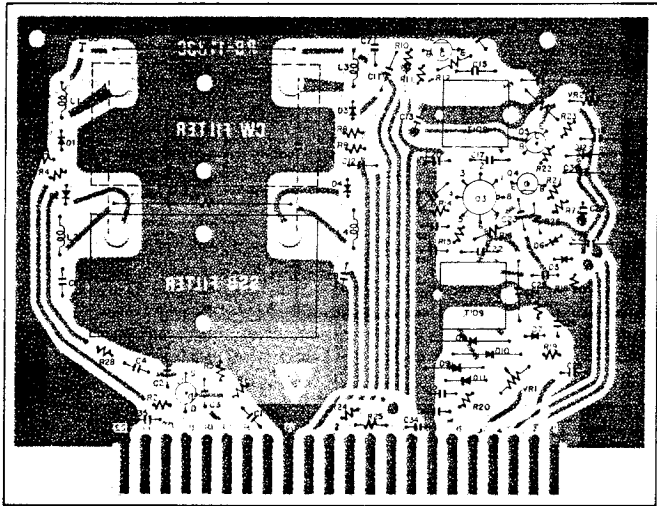

Viewed From Component Side

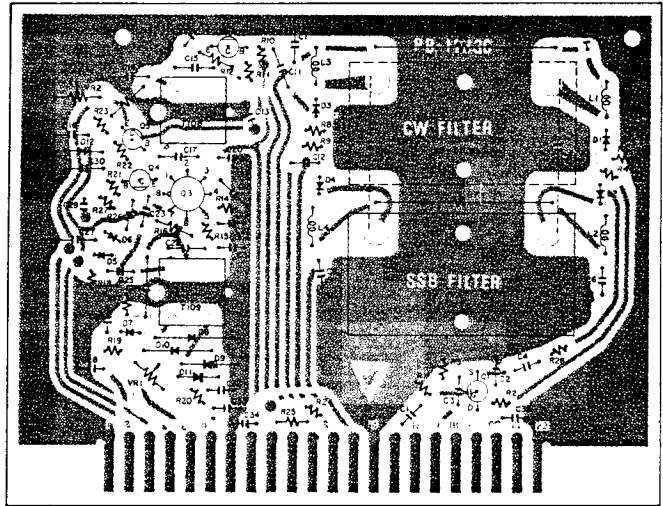

Viewed From Solder Side

# LOW FREQUENCY IF UNIT

## PB-1183

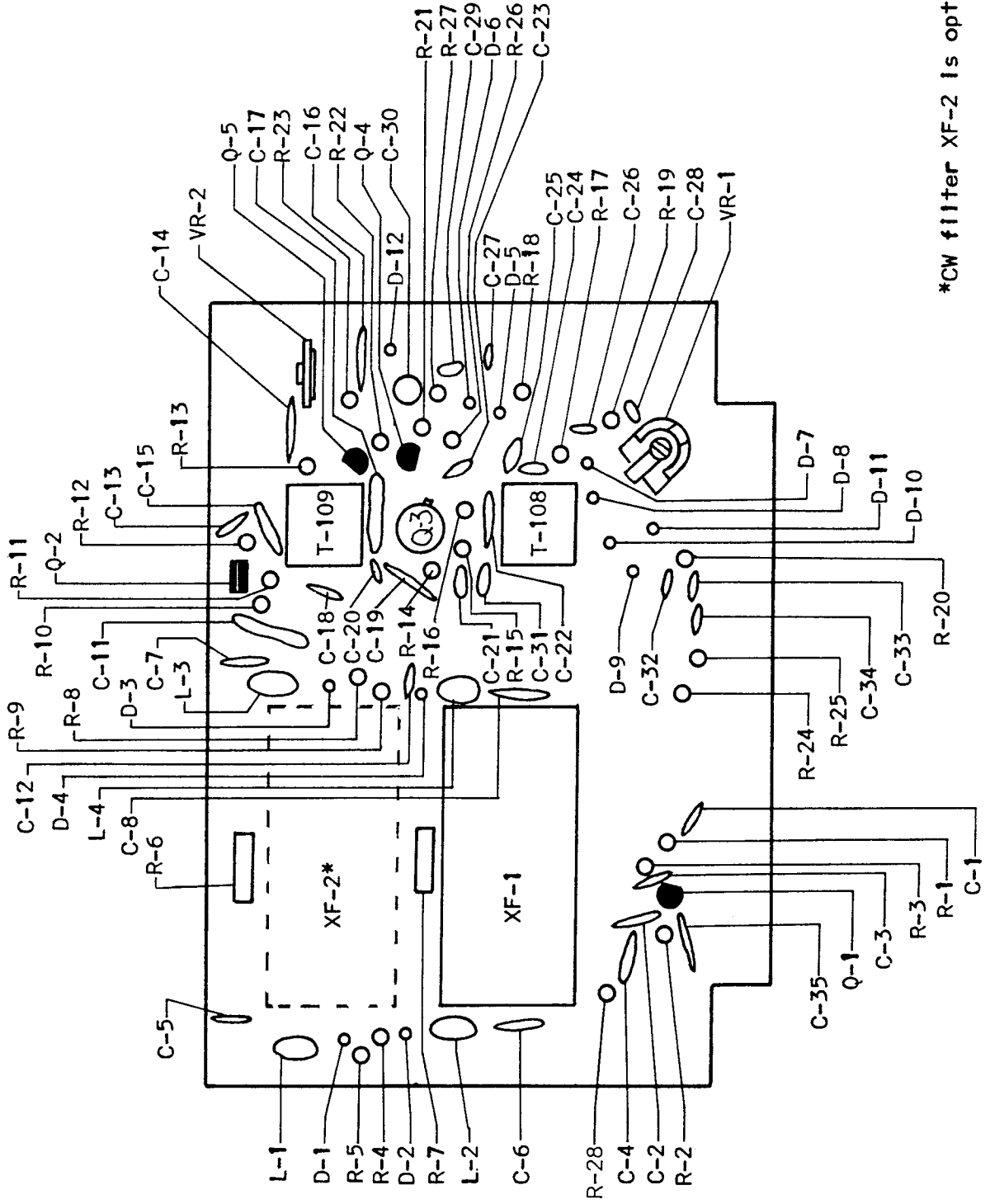

\*CW filter XF-2 is optional

# MOD. and OSC. UNIT PB-1184

FUNCTIONAL BLOCK DIAGRAM

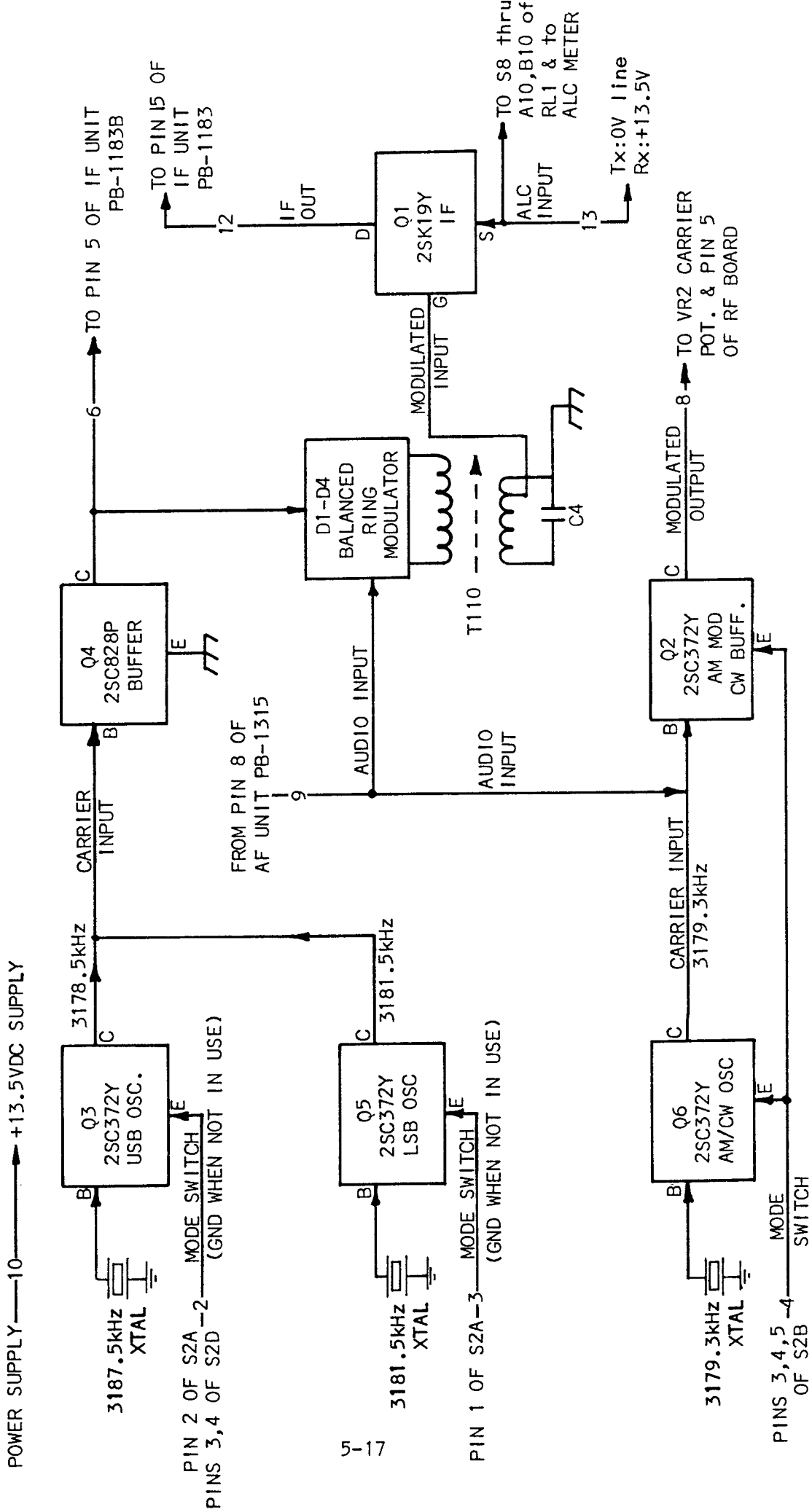



# MODULATOR UNIT PB-1184(A~Z)

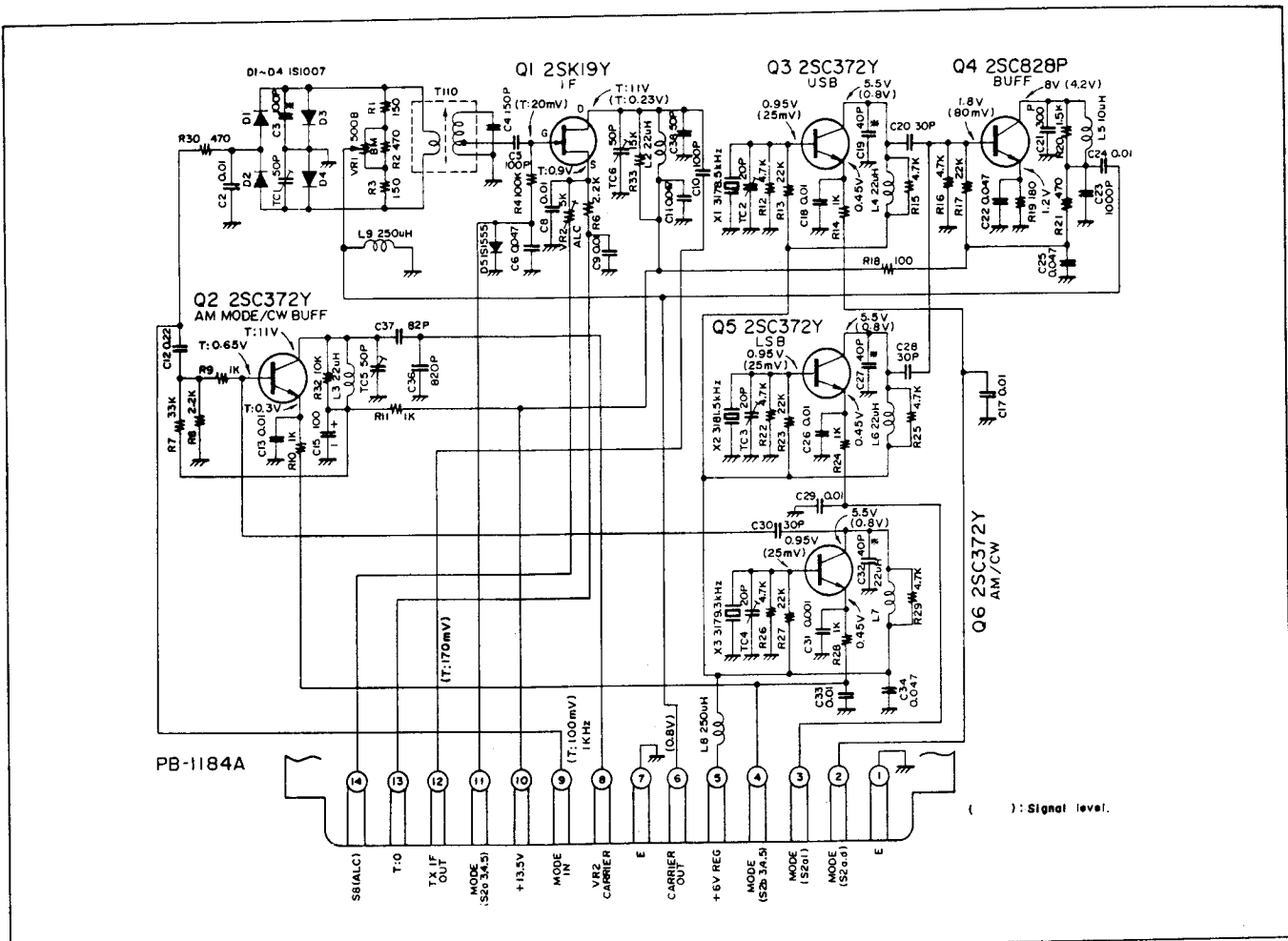

For Service Manuals Contact  
**MAURITRON TECHNICAL SERVICES**  
 8 Cherry Tree Rd, Chinnor  
 Oxon OX9 4QY  
 Tel:- 01844-351694 Fax:- 01844-352554  
 Email:- enquiries@mauritron.co.uk

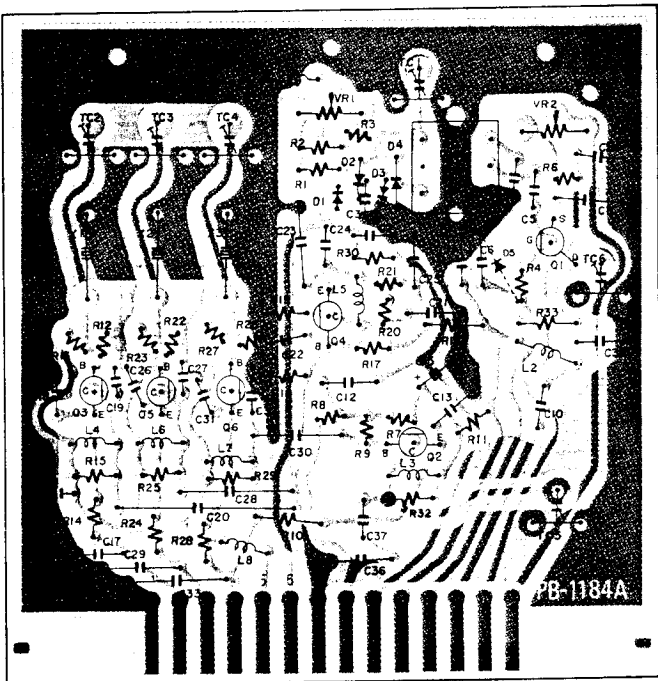

Viewed From Component Side

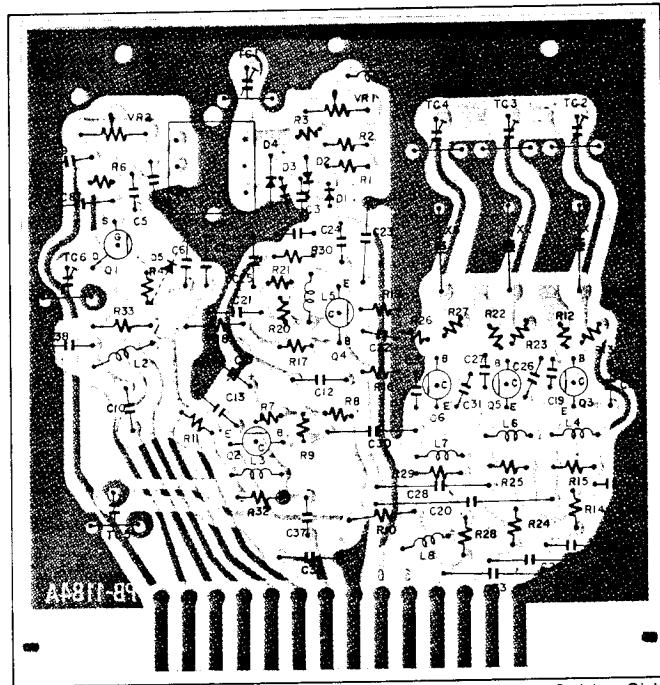

Viewed From Solder Side

# MODULATOR UNIT PB-1184

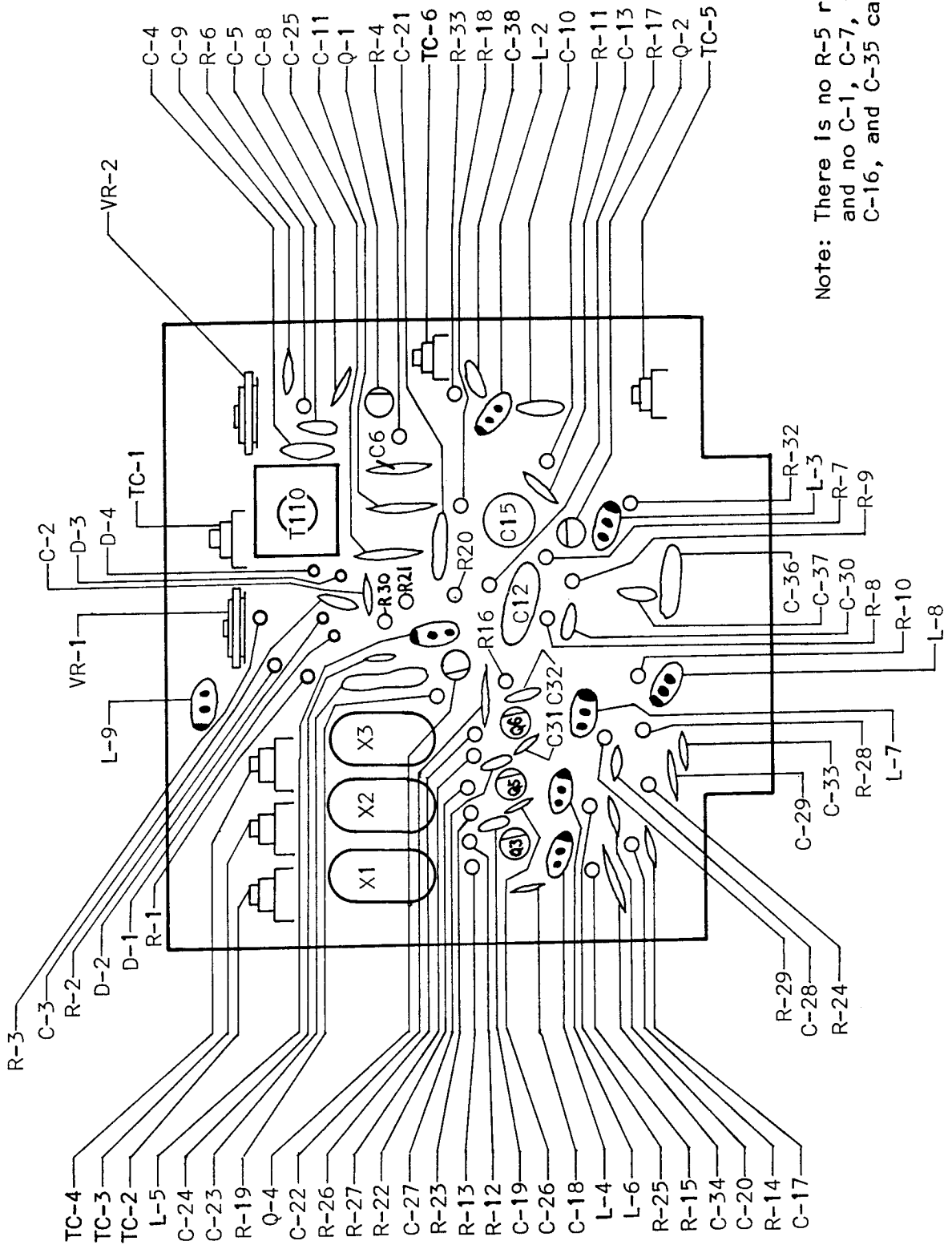

Note: There is no R-5 resistor and no C-1, C-7, C-14, C-16, and C-35 capacitors

# NOISE BLANKER UNIT PB-1292(A~Z)

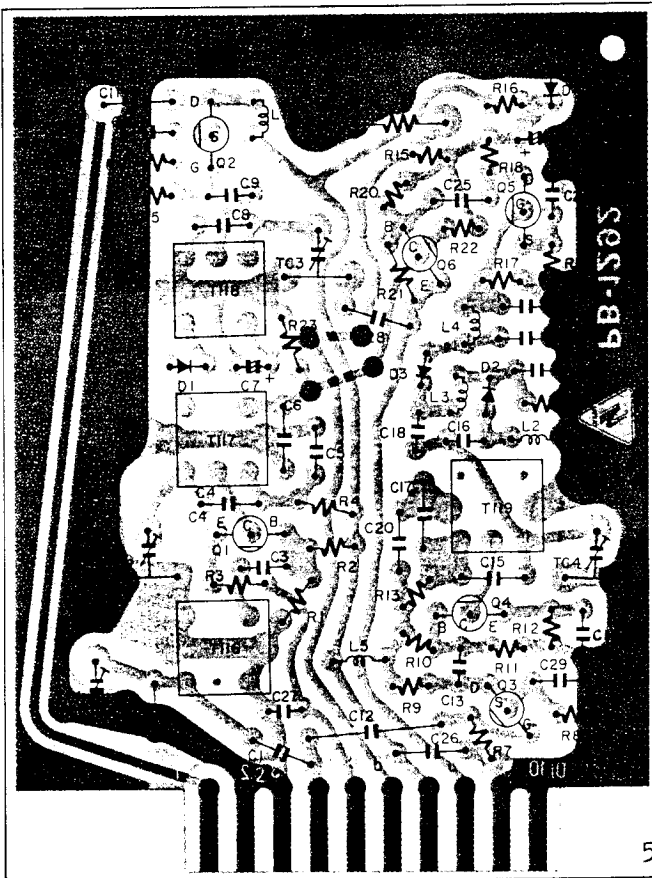
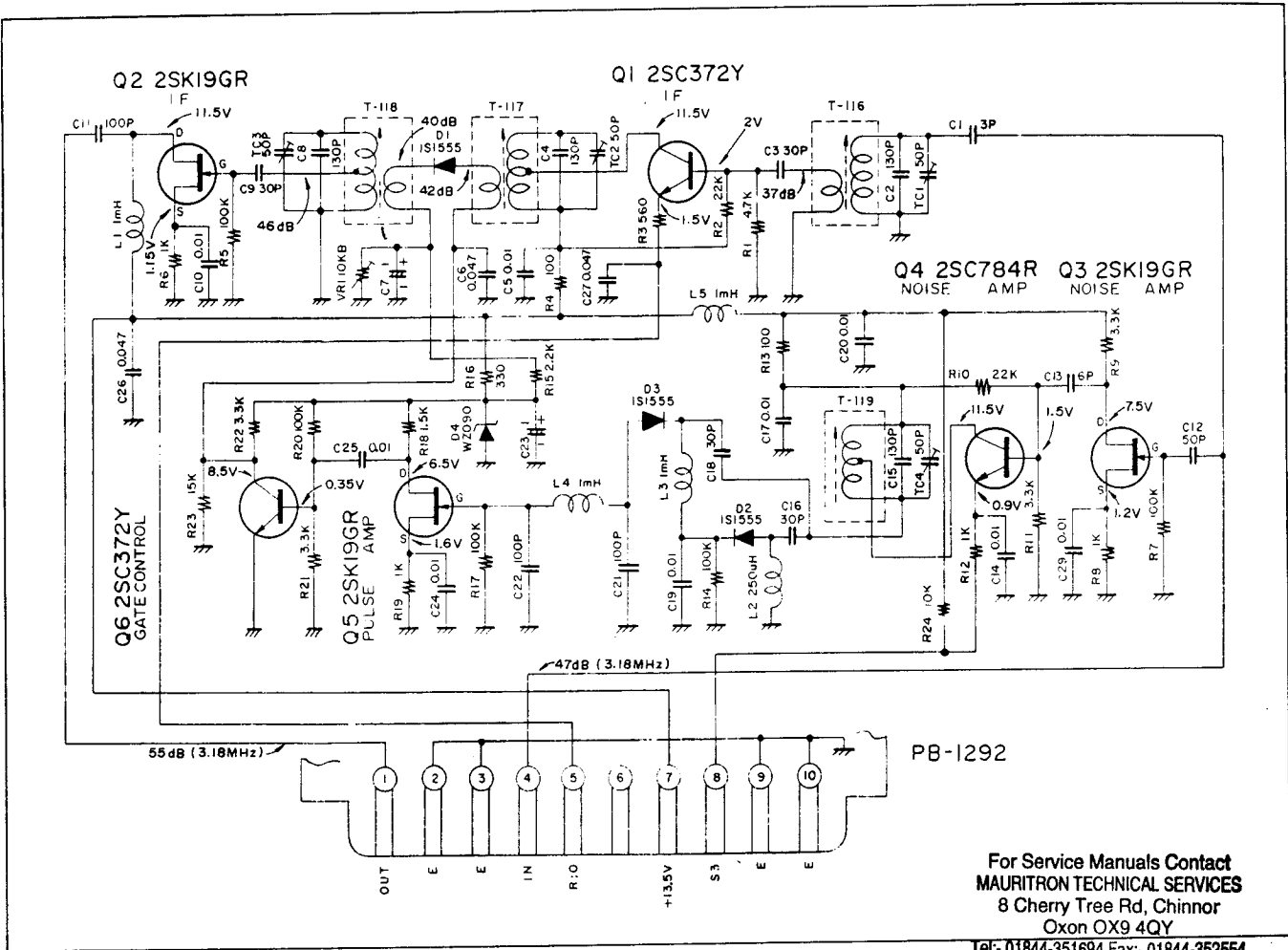

Viewed From Component Side

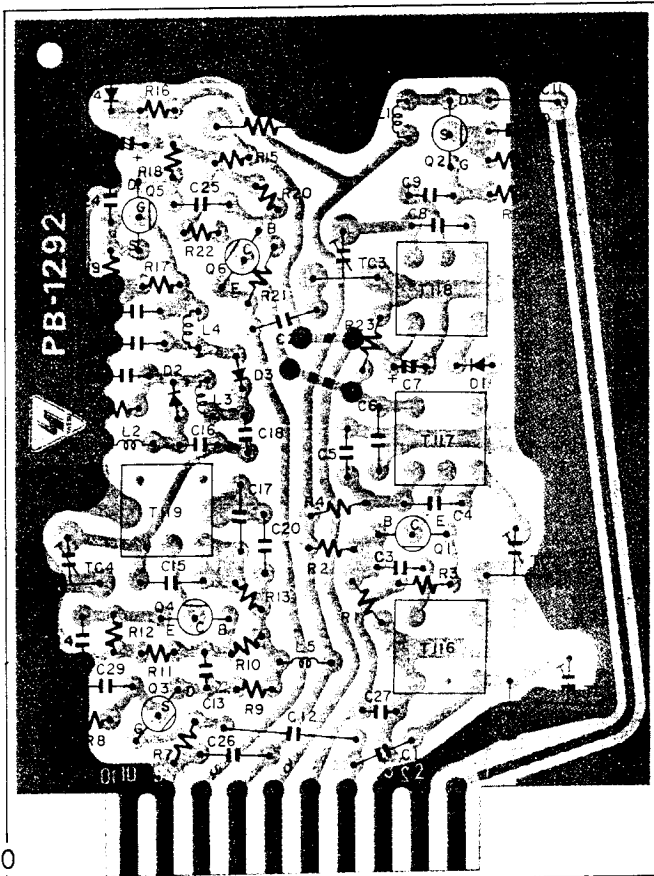

Viewed From Solder Side

# NOISE BLANKER UNIT PB-1292

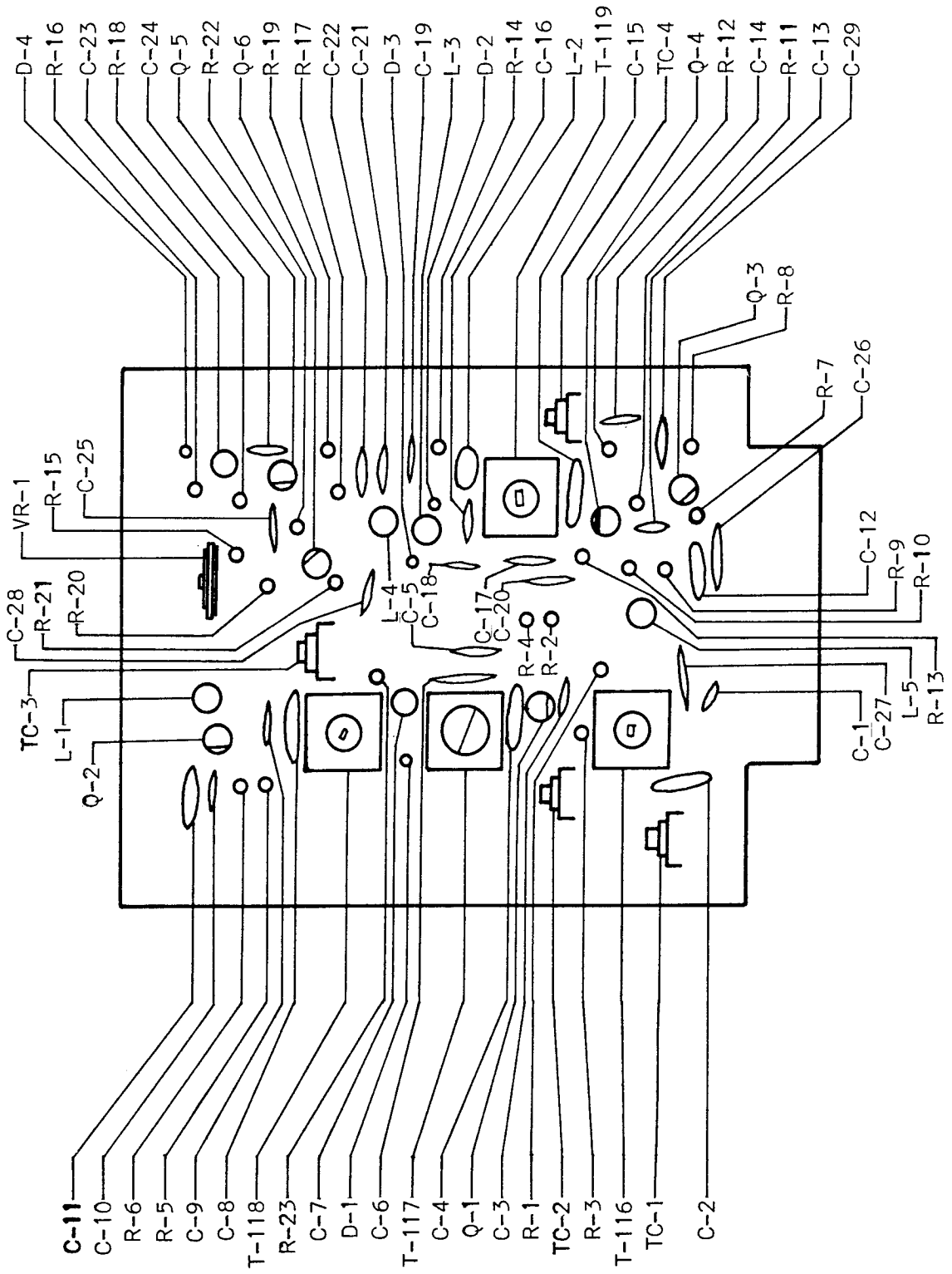

# POWER REGULATOR UNIT PB-1314 (A~Z)

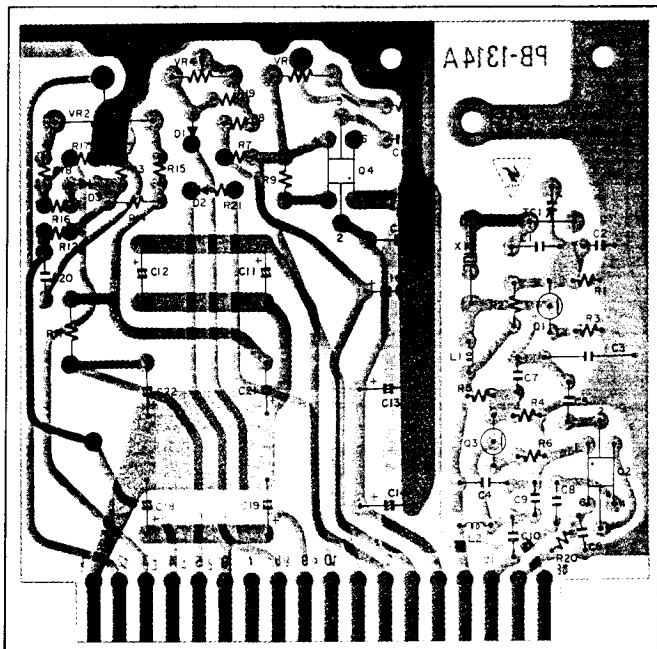
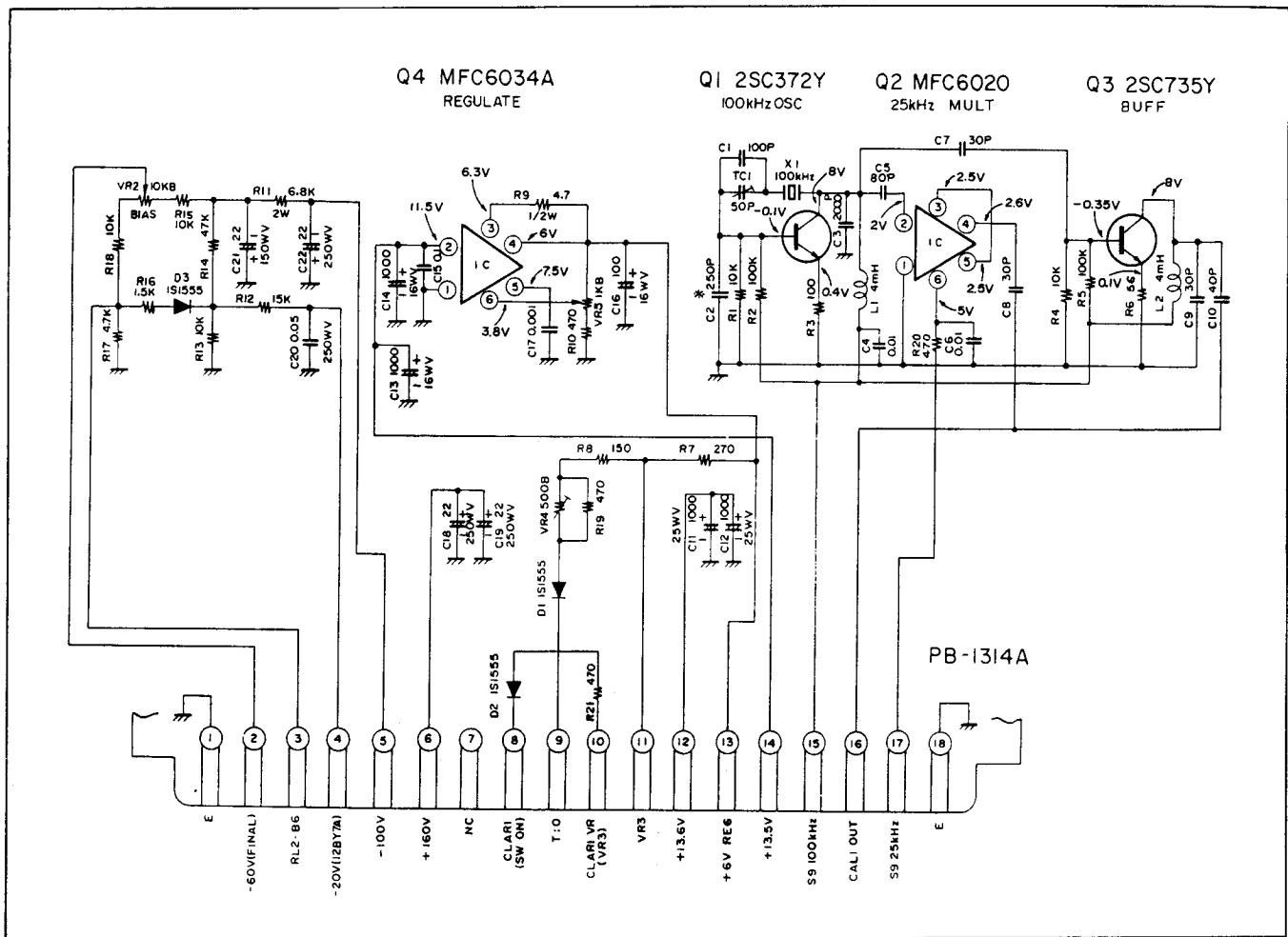

Viewed From Component Side

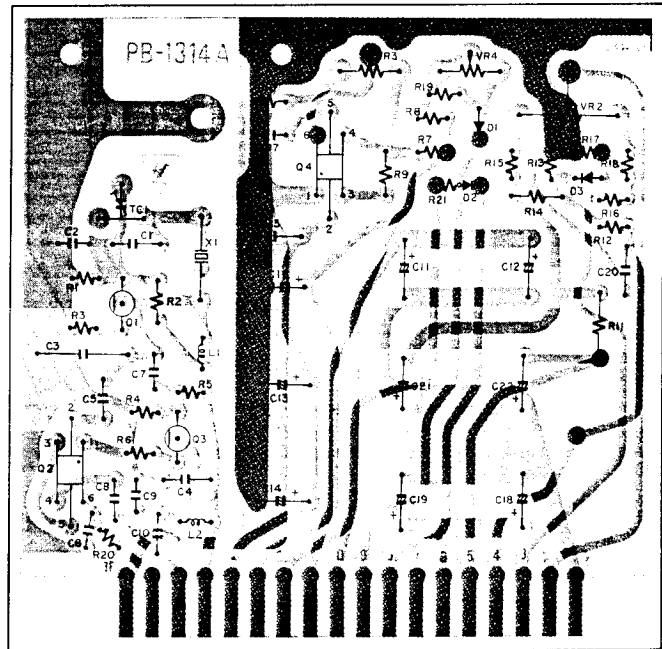

Viewed From Solder Side

# POWER REGULATOR UNIT

## PB-1314

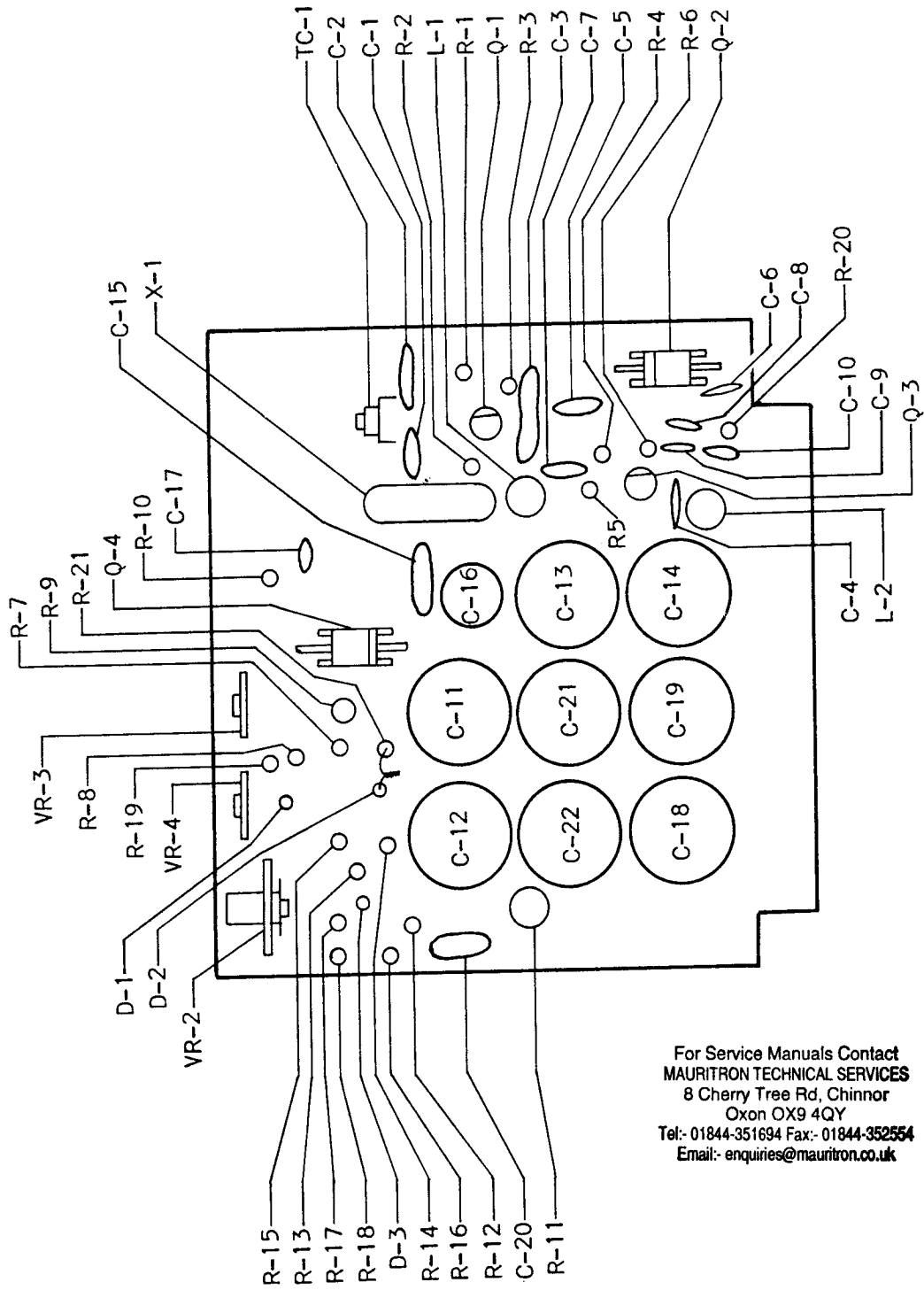

For Service Manuals Contact  
**MAURITRON TECHNICAL SERVICES**  
 8 Cherry Tree Rd, Chinnor  
 Oxon OX9 4QY  
 Tel: 01844-351694 Fax: 01844-352554  
 Email: enquiries@mauritron.co.uk

# AUDIO UNIT PB-1315

FUNCTIONAL BLOCK DIAGRAM

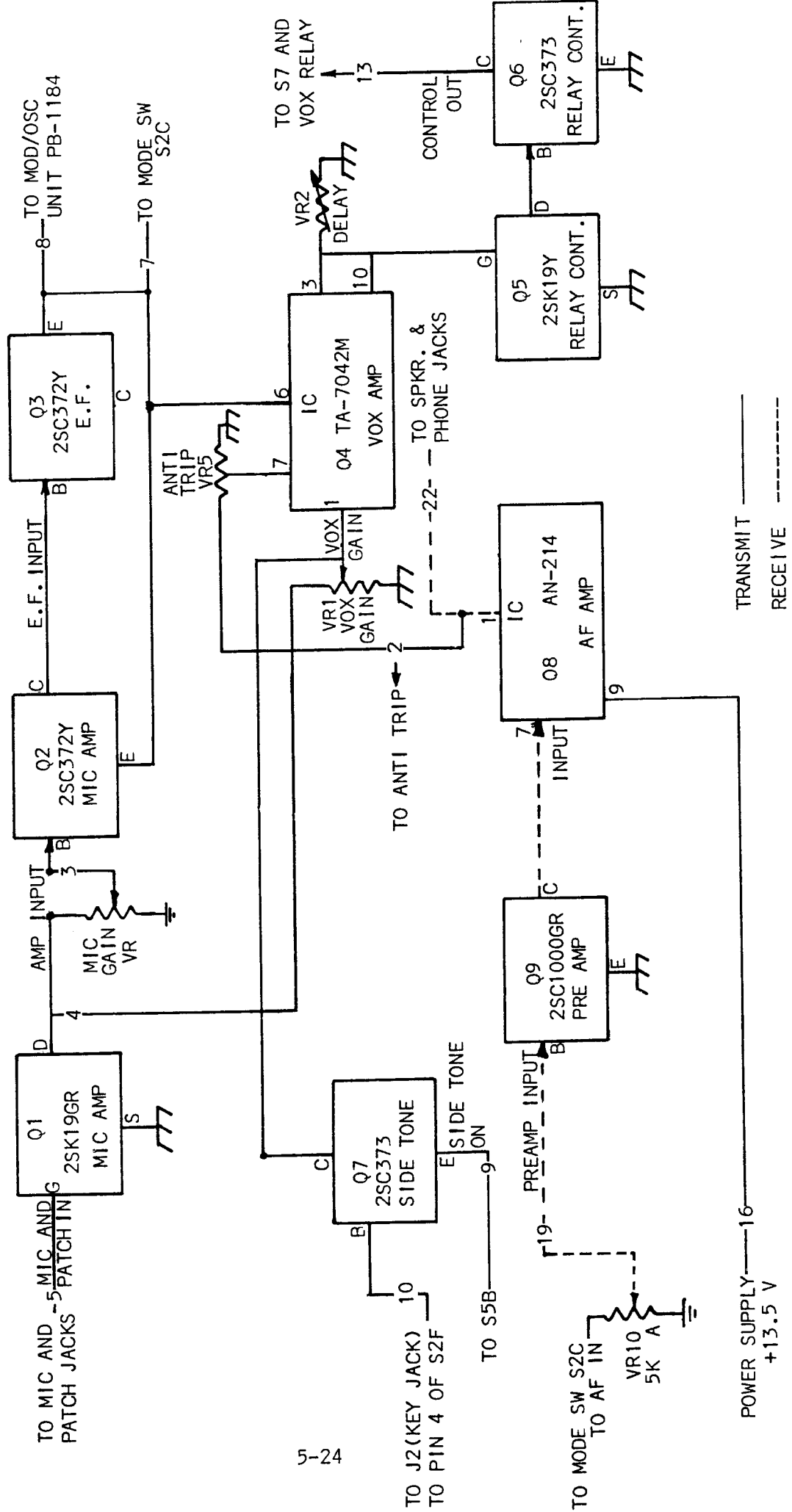

# AUDIO UNIT PB-1315(A~Z)

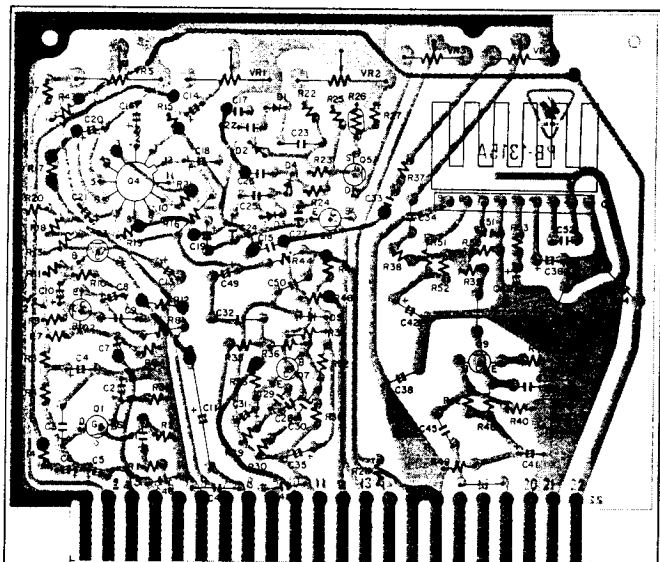
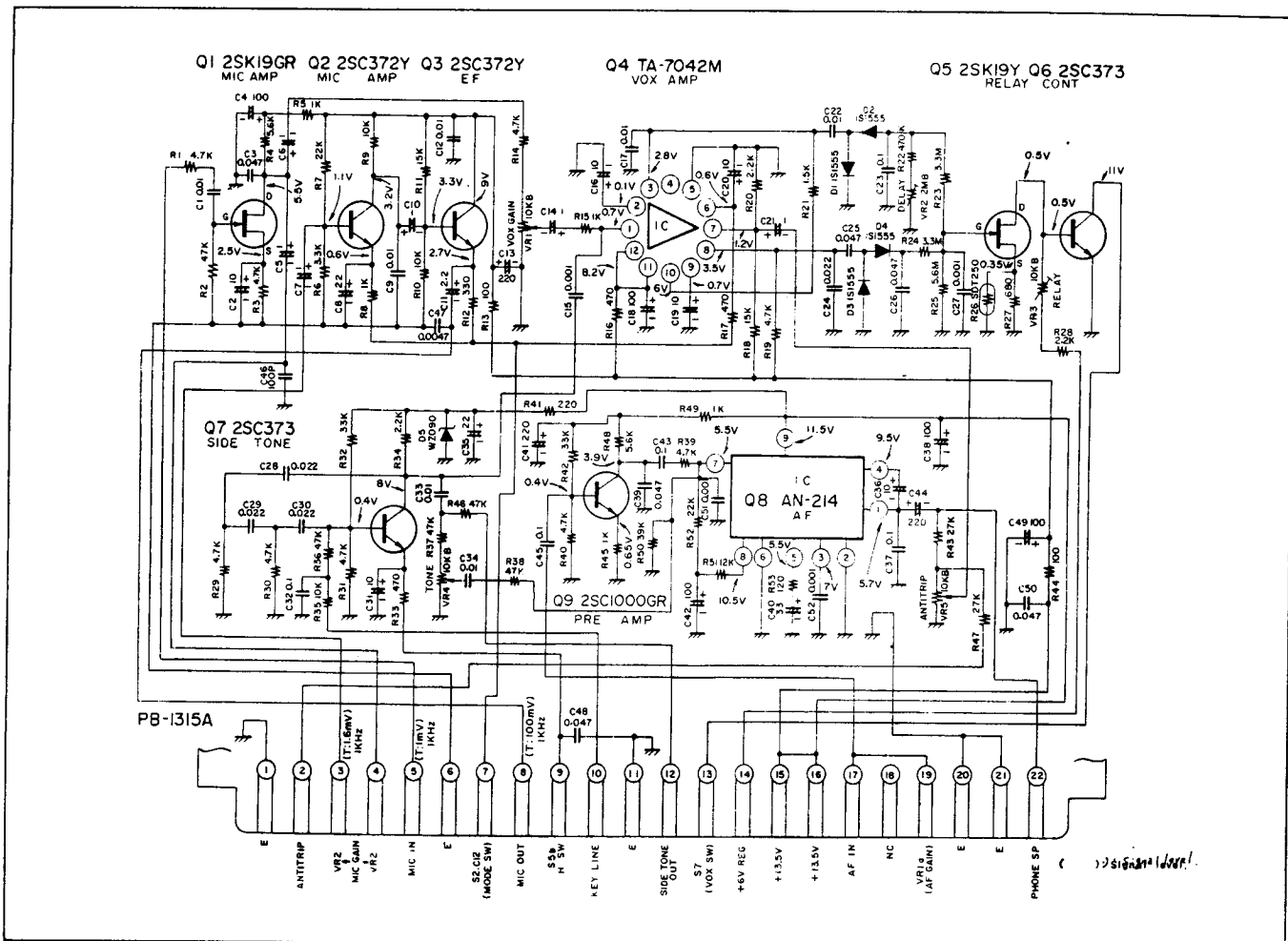

Viewed From Component Side

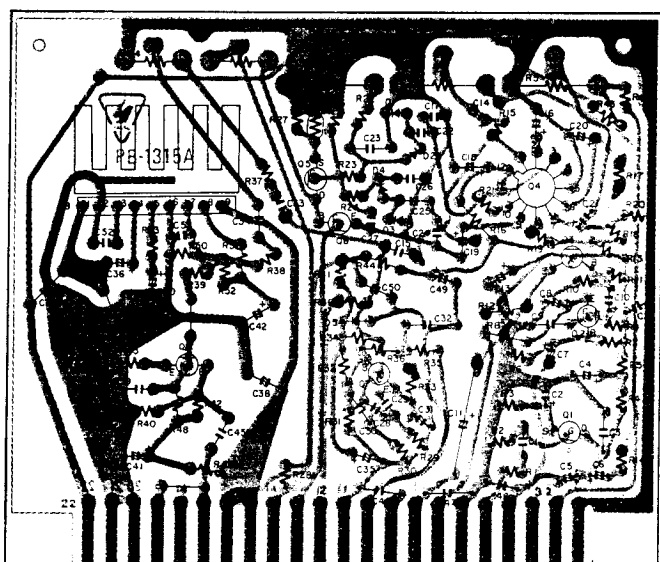

Viewed From Solder Side



# AUDIO UNIT

## PB-1315

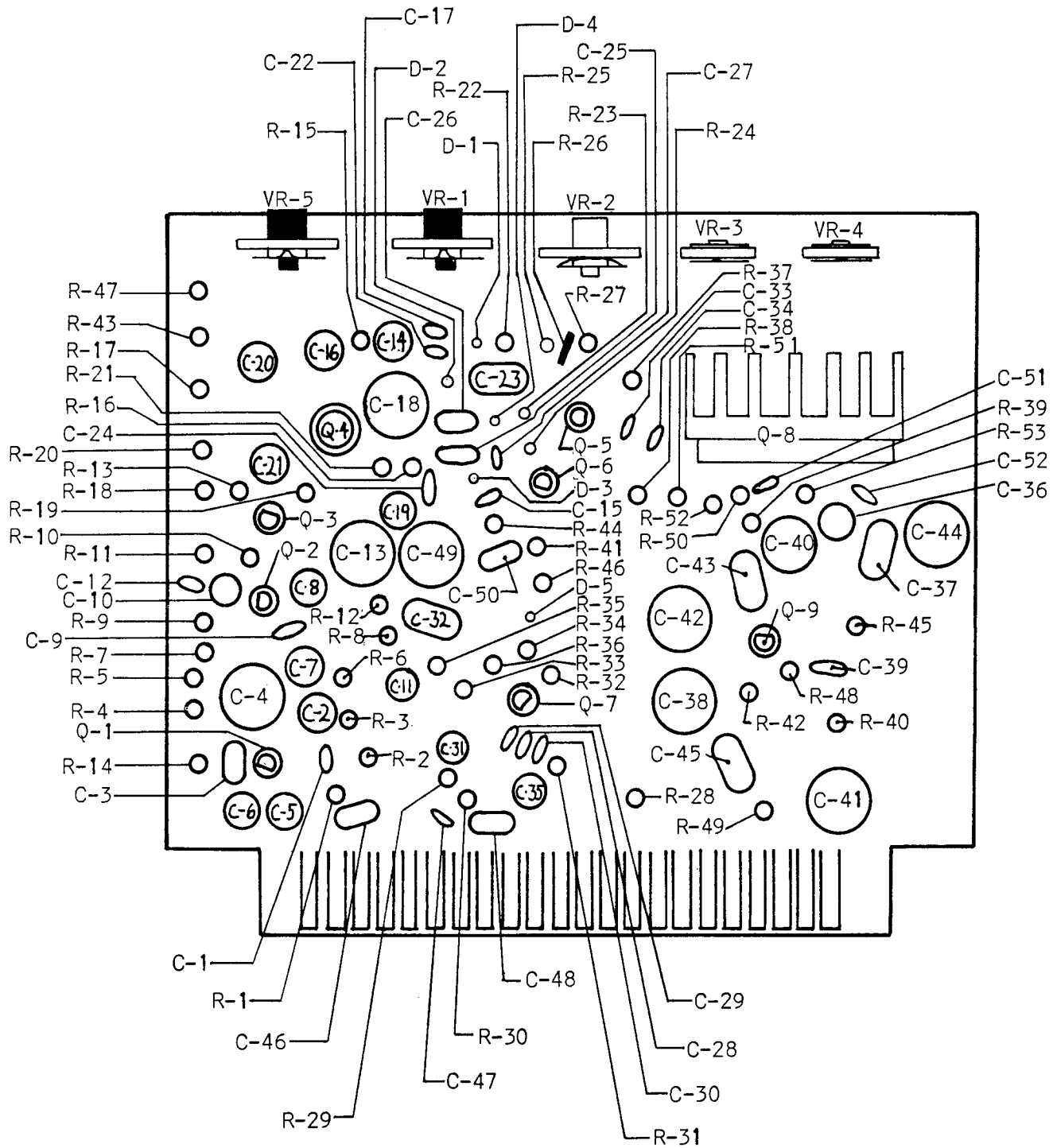

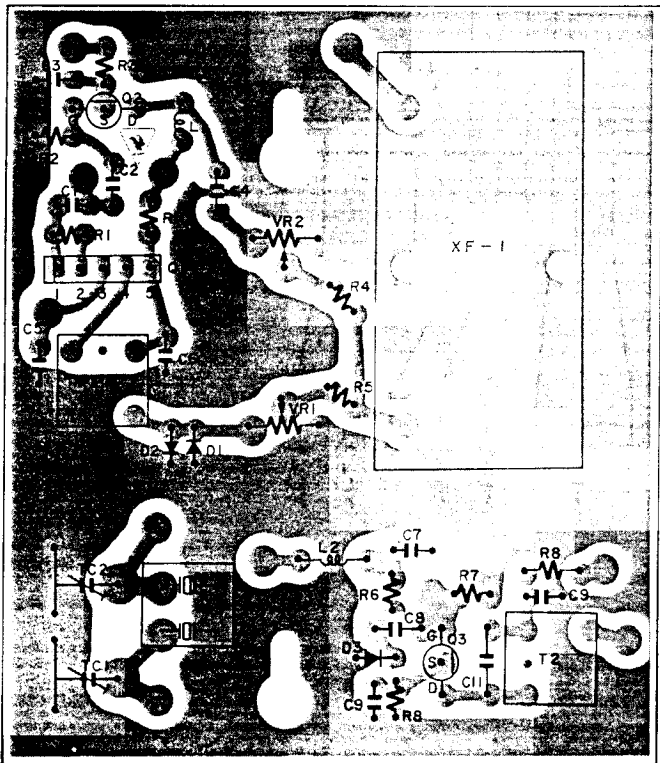
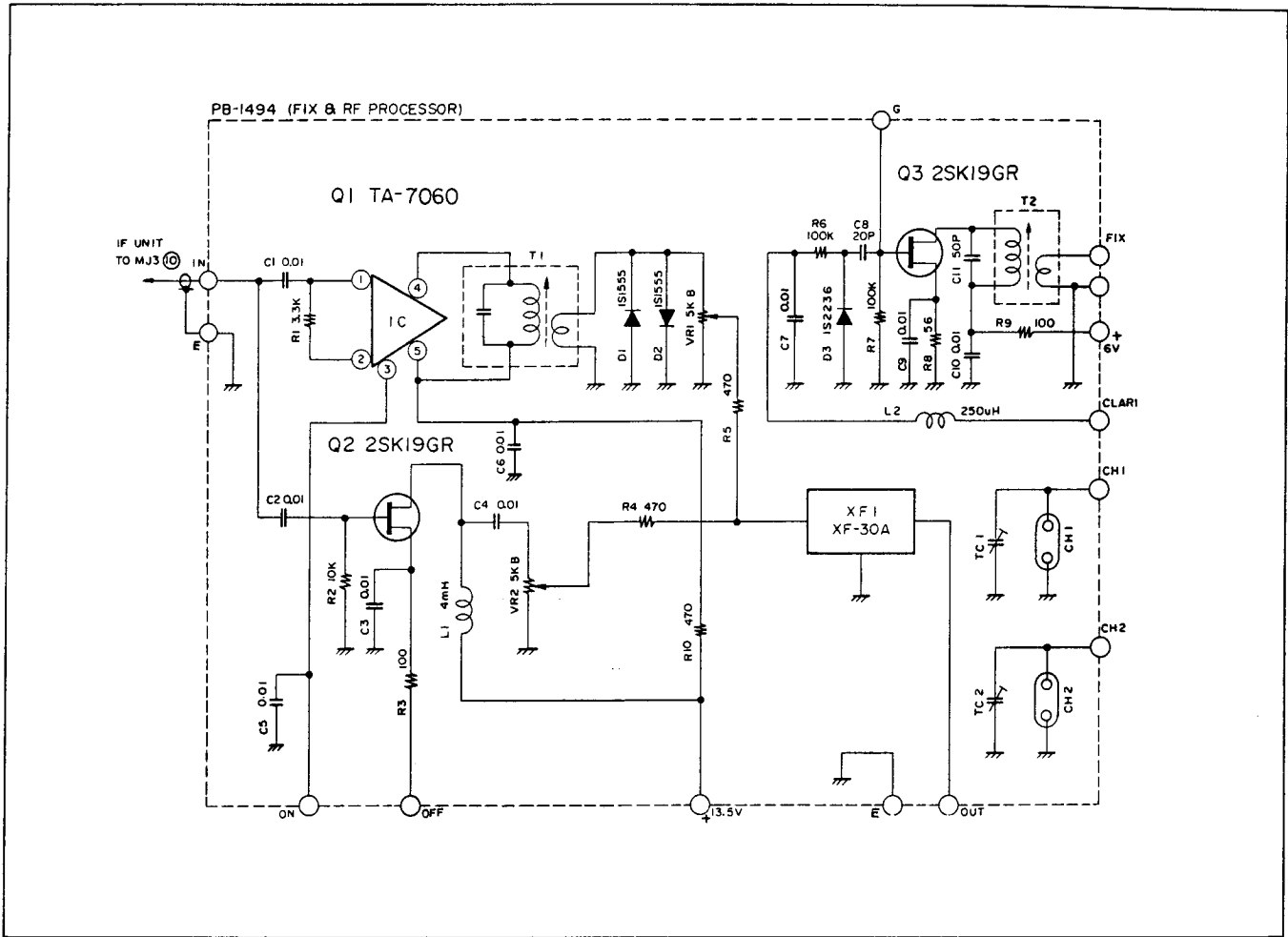

Viewed From Component Side

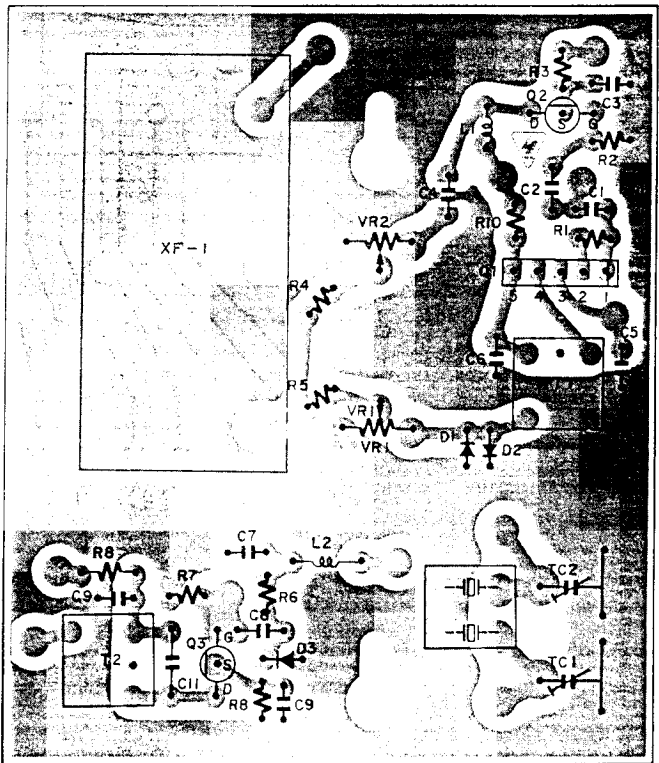

Viewed From Solder Side

# RF SPEECH PROCESSOR CRYSTAL CONTROL

## PB-1494

For Service Manuals Contact  
**MAURITRON TECHNICAL SERVICES**  
 8 Cherry Tree Rd, Chinnor  
 Oxon OX9 4QY  
 Tel:- 01844-351694 Fax:- 01844-352554  
 Email:- enquiries@mauritron.co.uk

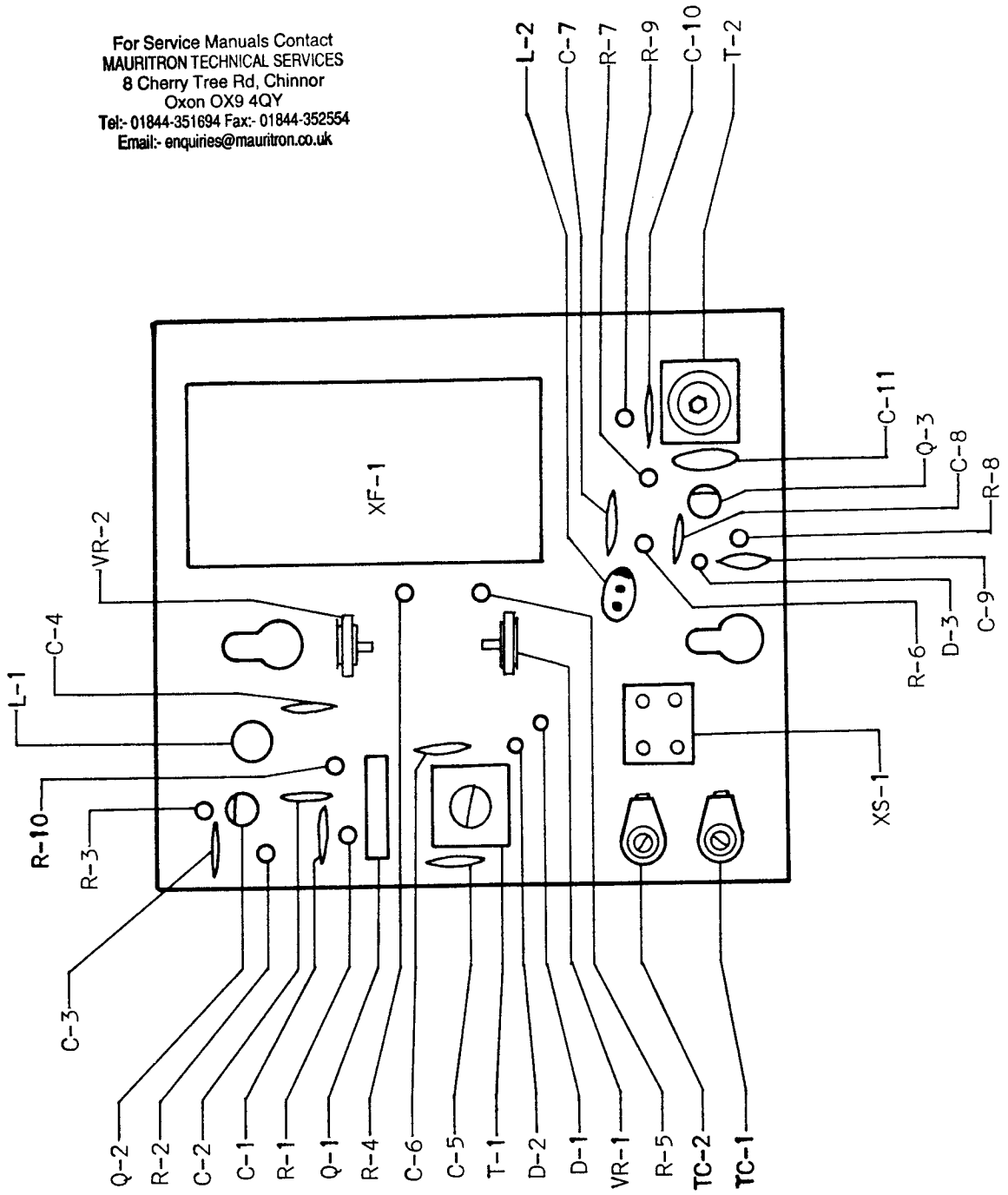

# RF SPEECH PROCESSOR, CONTROL UNIT PB-1534(A~Z)

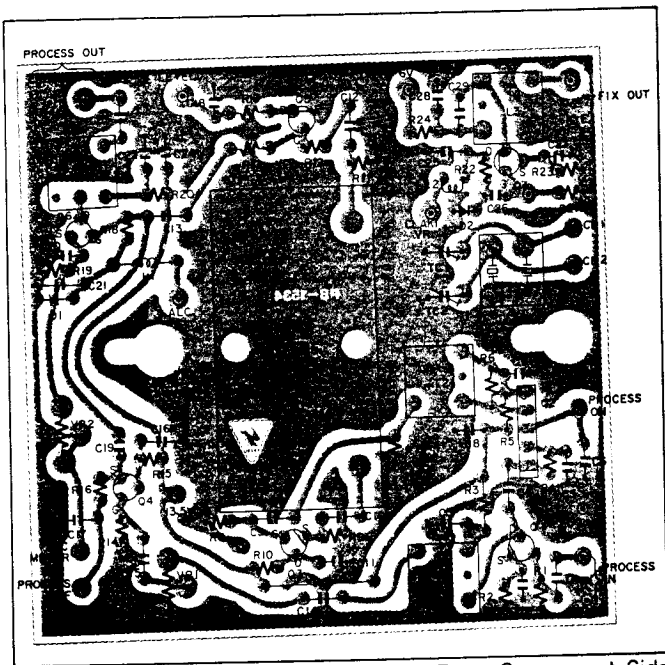
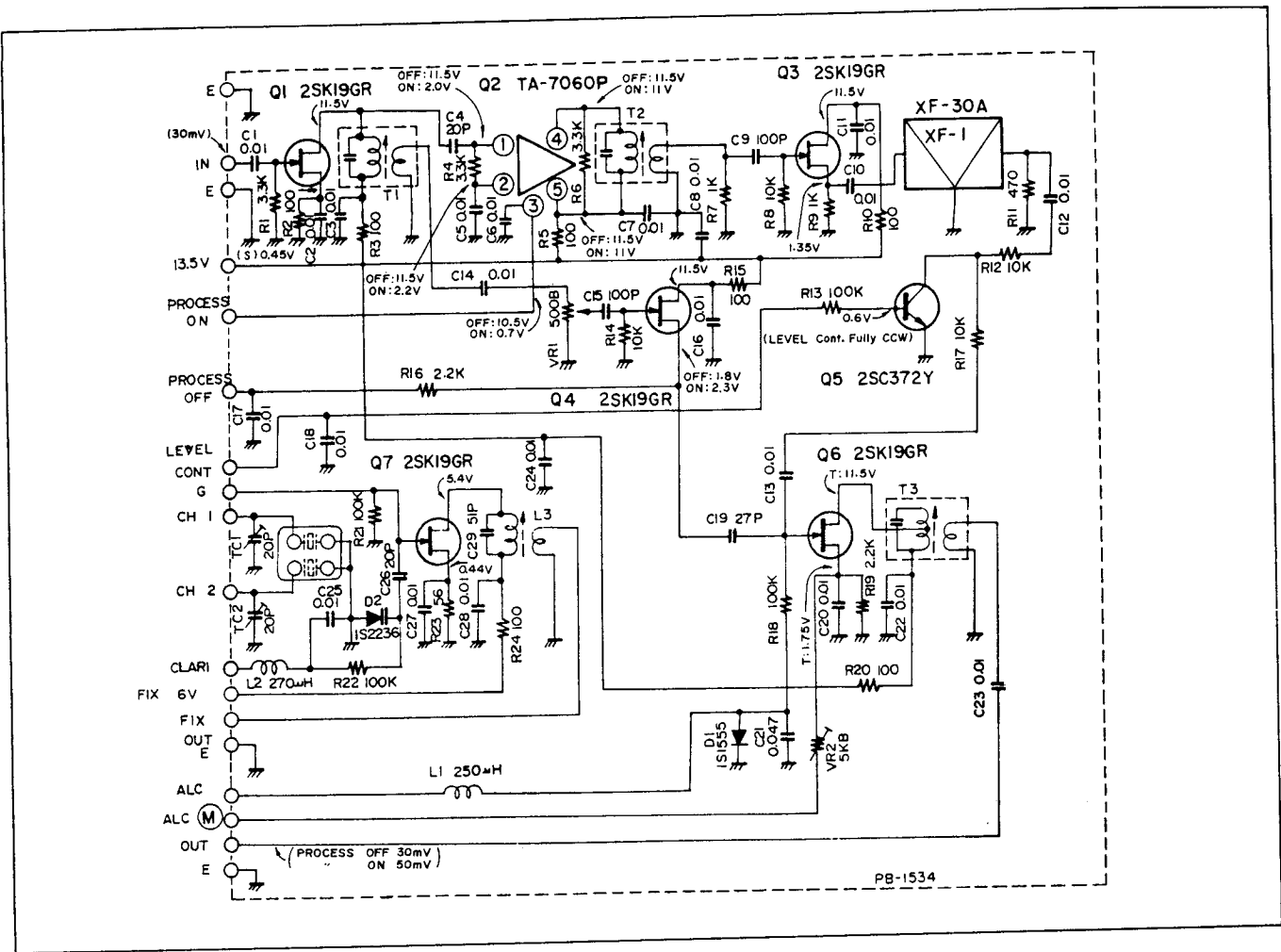

Viewed From Component Side

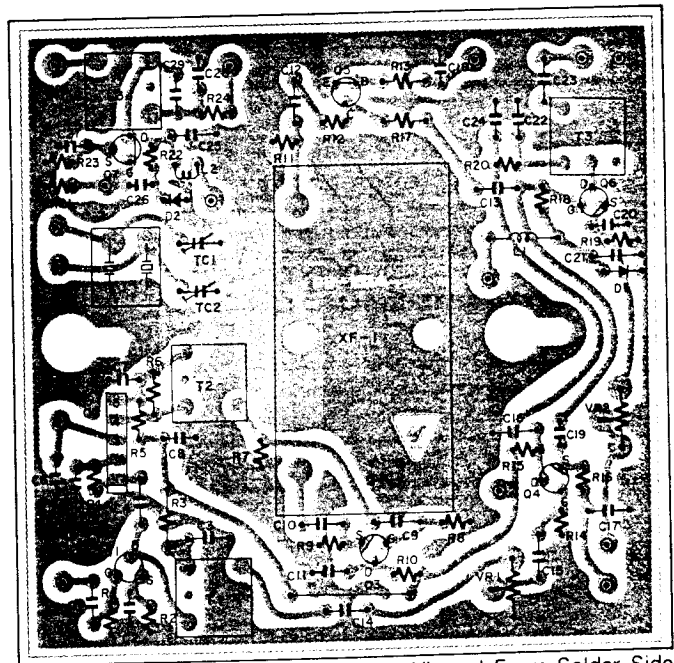

Viewed From Solder Side

# RF SPEECH PROCESSOR

PB-1534

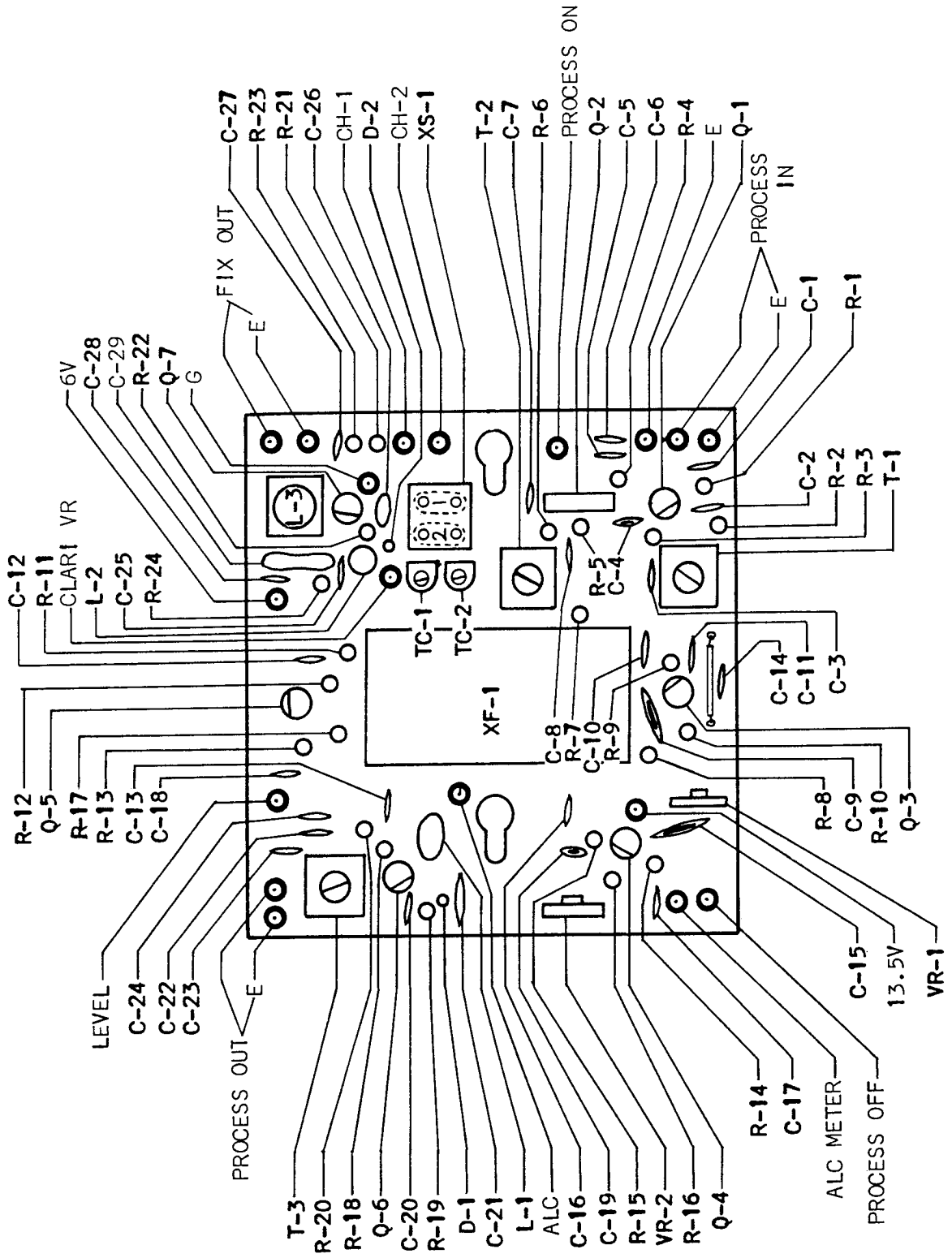

# REG. and CALIB. UNIT PB-1547

FUNCTIONAL BLOCK DIAGRAM

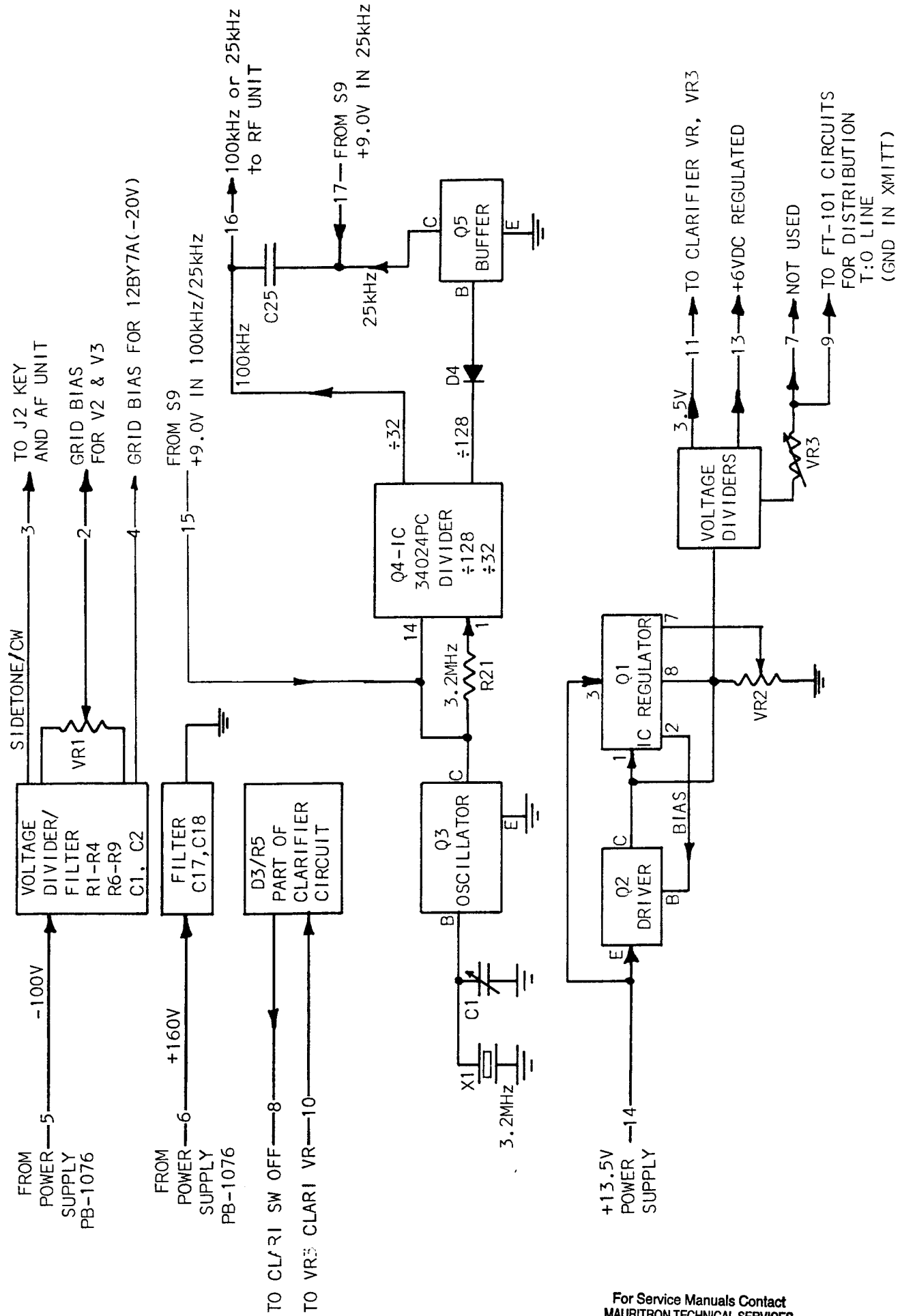

For Service Manuals Contact  
**MAURITRON TECHNICAL SERVICES**  
 8 Cherry Tree Rd, Chinnor  
 Oxon OX9 4QY  
 Tel:- 01844-351694 Fax:- 01844-352554  
 Email:- enquiries@mauritron.co.uk

# POWER REGULATOR UNIT PB-1547

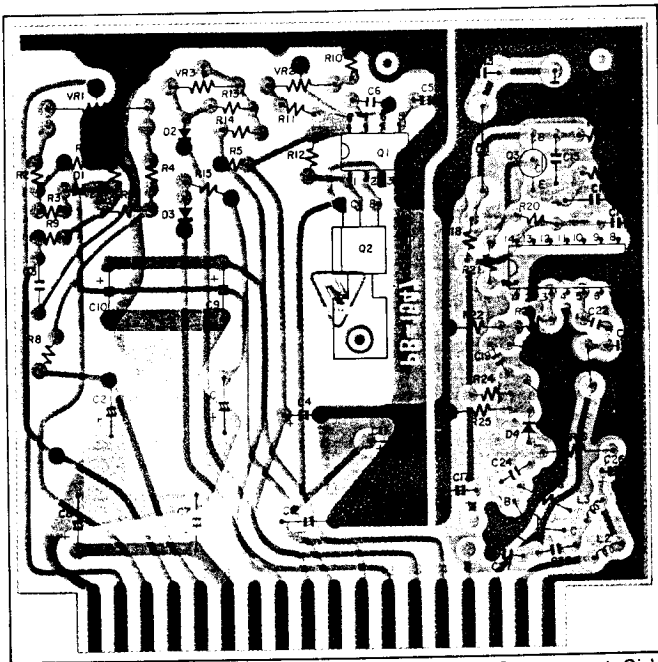
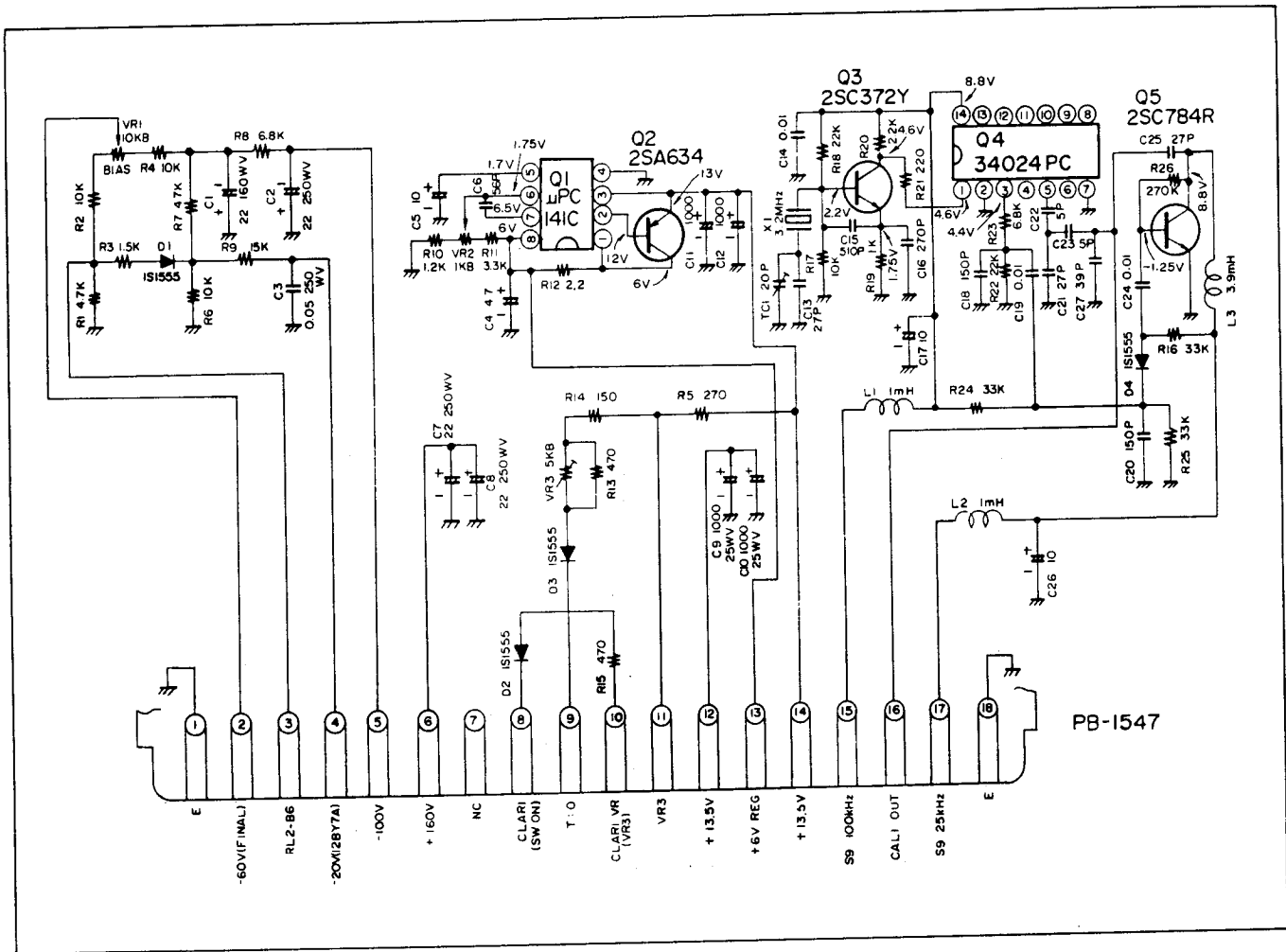

Viewed From Component Side

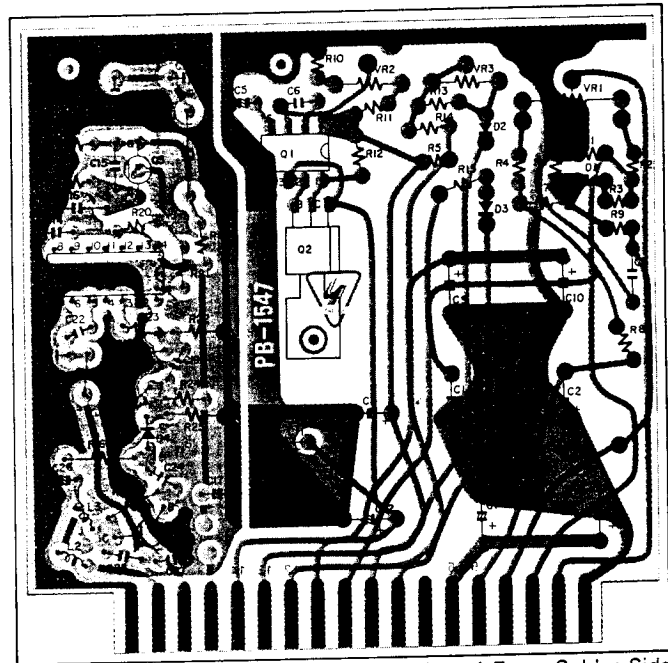

Viewed From Solder Side

# POWER REGULATOR UNIT

## PB-1547

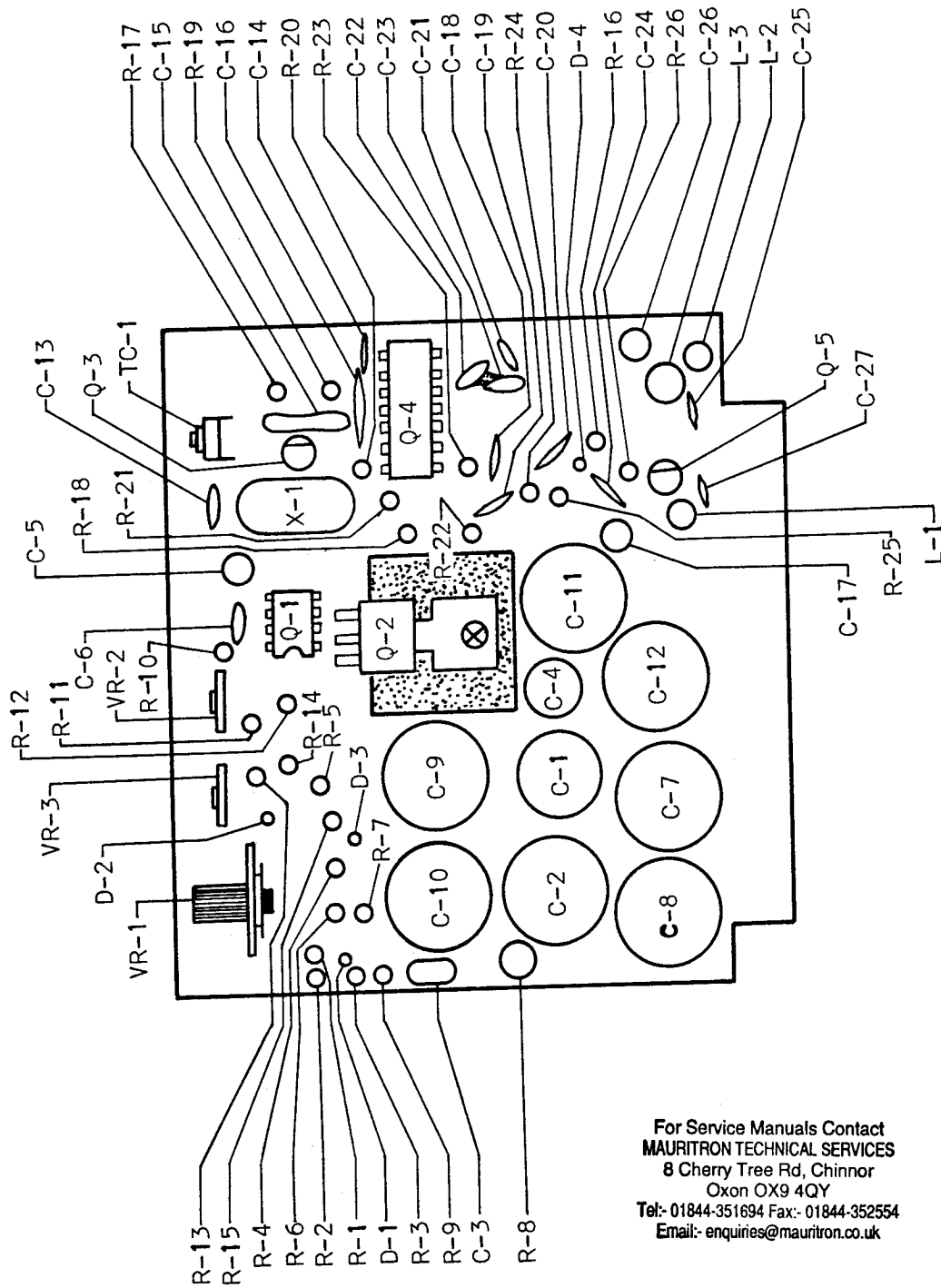

For Service Manuals Contact  
**MAURITRON TECHNICAL SERVICES**  
 8 Cherry Tree Rd, Chinnor  
 Oxon OX9 4QY  
 Tel:- 01844-351694 Fax:- 01844-352554  
 Email:- enquiries@mauritron.co.uk



# NOISE BLANKER PB-1582

FUNCTIONAL BLOCK DIAGRAM

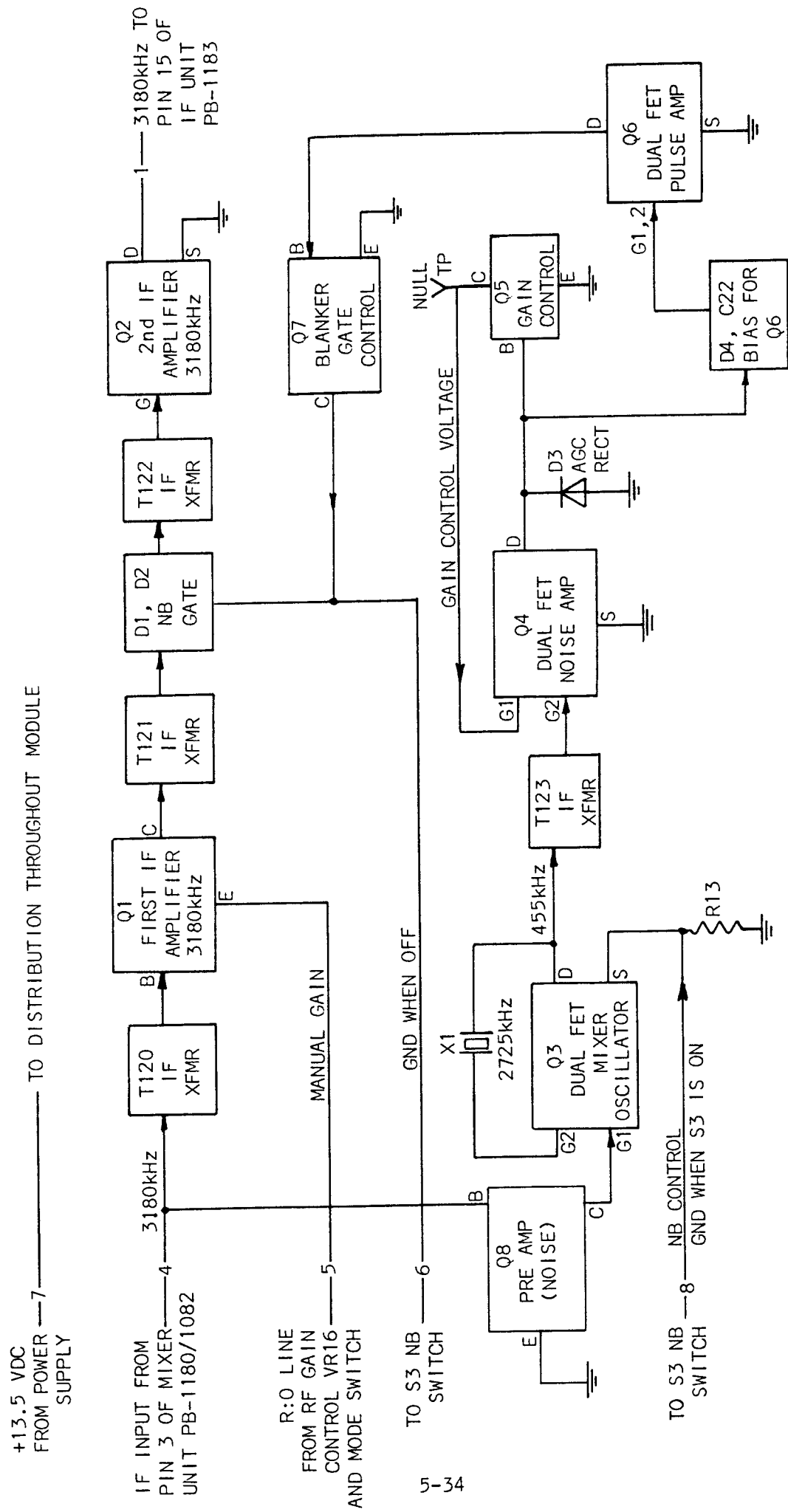

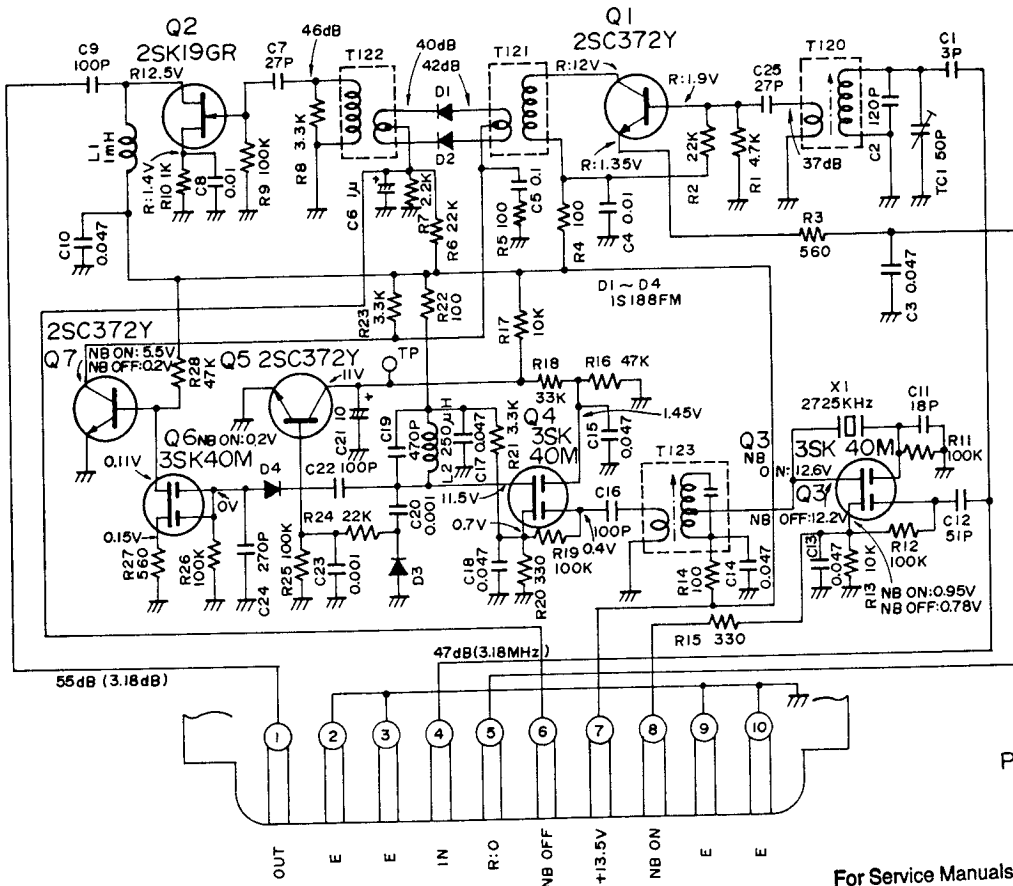

PB-1582

For Service Manuals Contact  
**MAURITRON TECHNICAL SERVICES**  
 8 Cherry Tree Rd, Chinnor  
 Oxon OX9 4QY  
 Tel: 01844-351694 Fax: 01844-352554  
 Email: enquiries@mauritron.co.uk

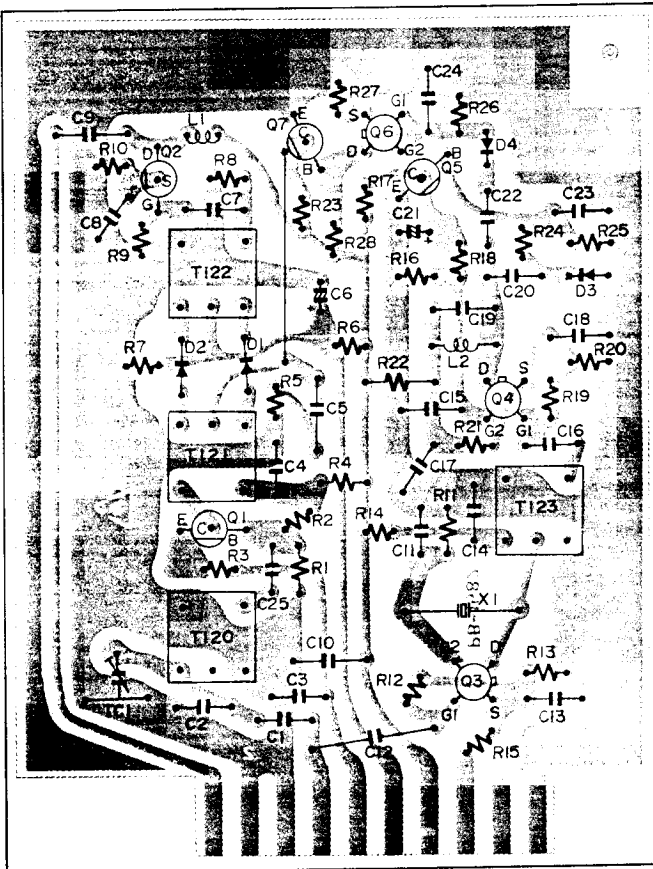

Viewed From Component Side

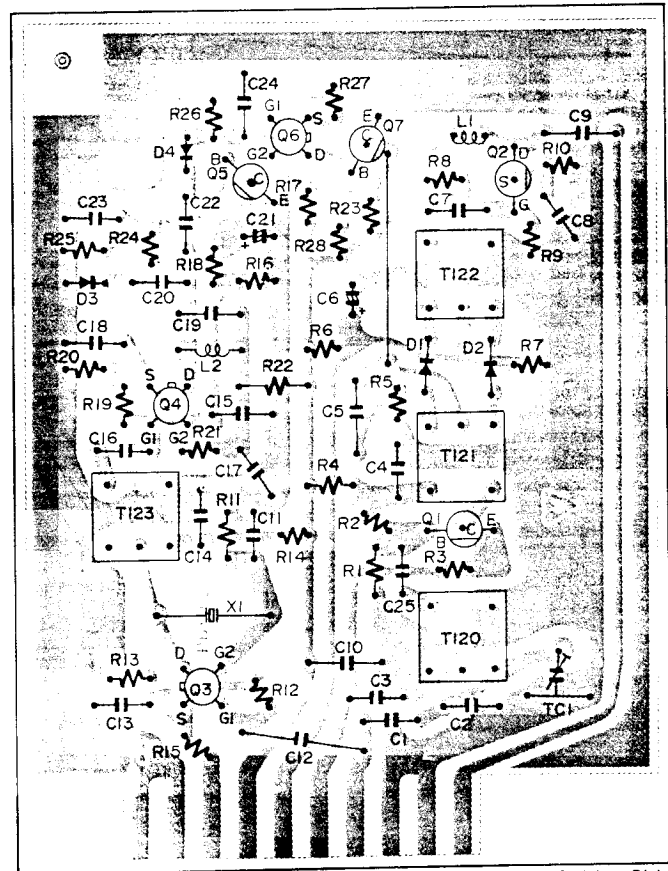

Viewed From Solder Side

# NOISE BLANKER UNIT PB-1582

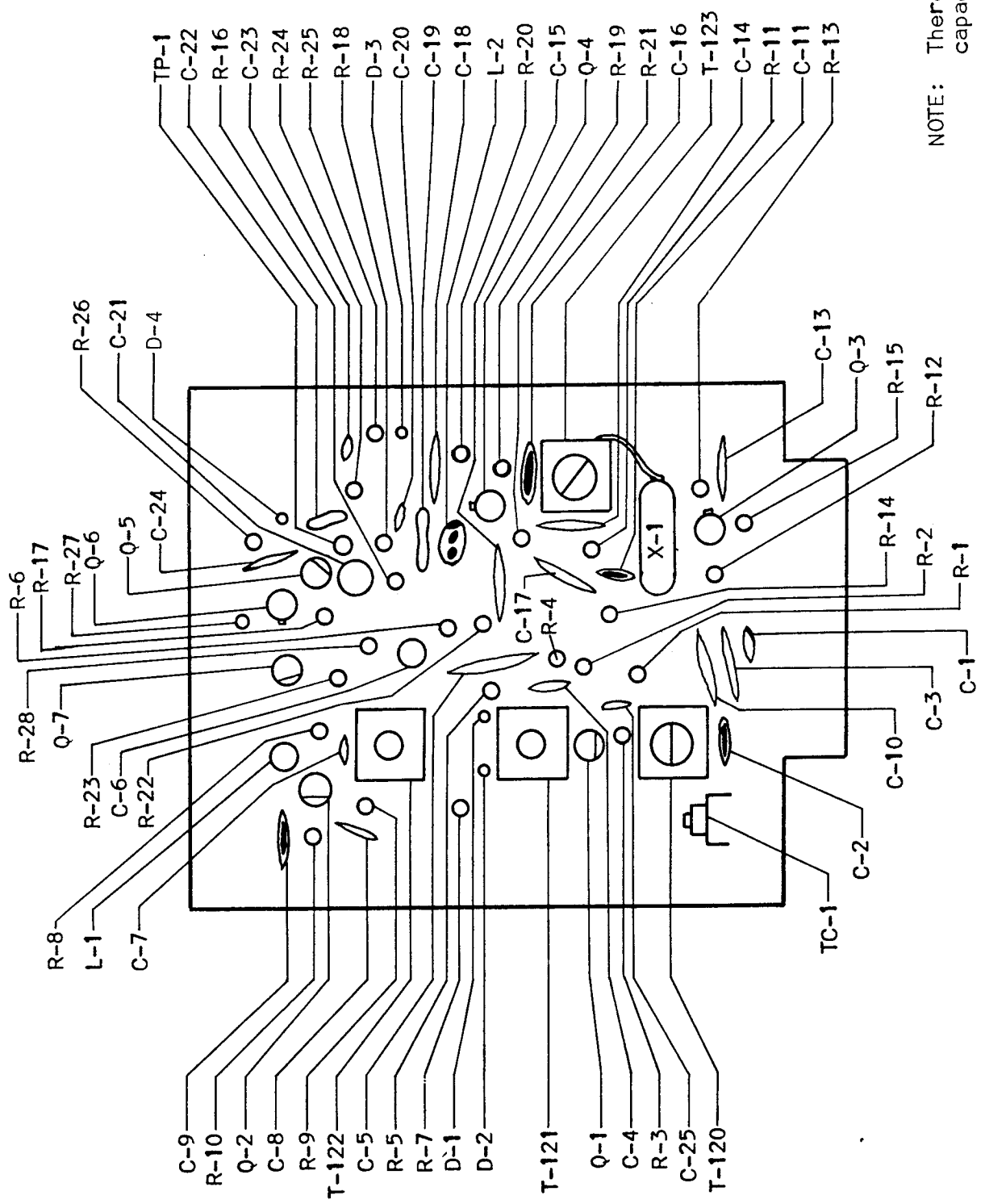

NOTE: There is no C-12 capacitor

MAIN CHASSIS

RF TRIMMER BOARD PB-1188(A~Z)

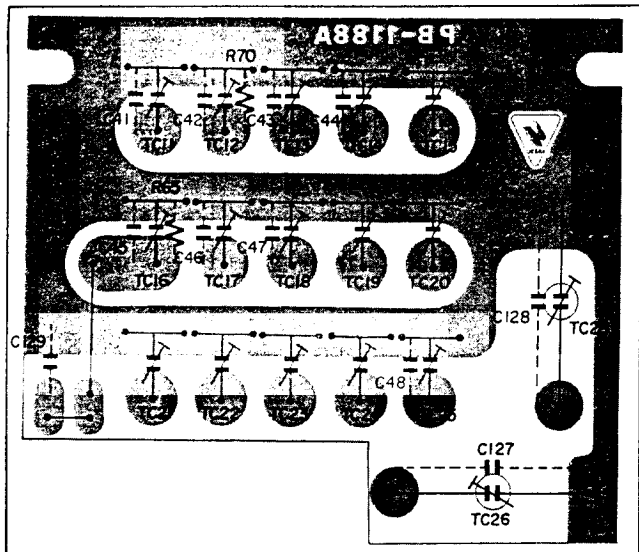

Viewed From Component Side

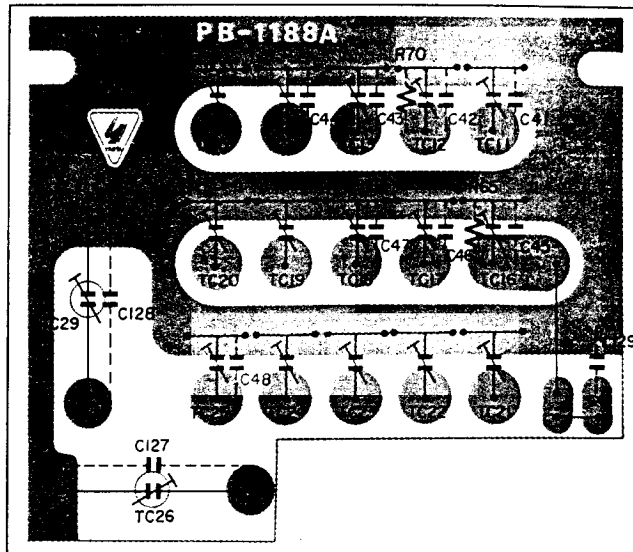

Viewed From Solder Side

TRIMMER A BOARD PB-1187(A~Z)

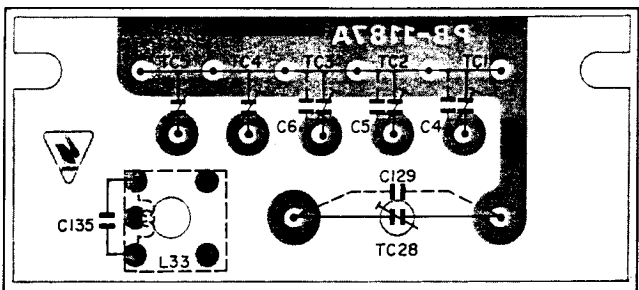

Viewed From Component Side

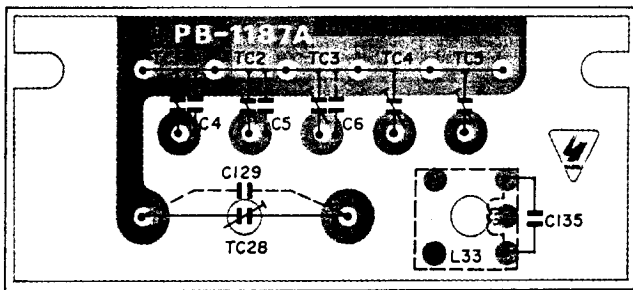

Viewed From Solder Side

TRIMMER B BOARD PB-1092(A~Z)

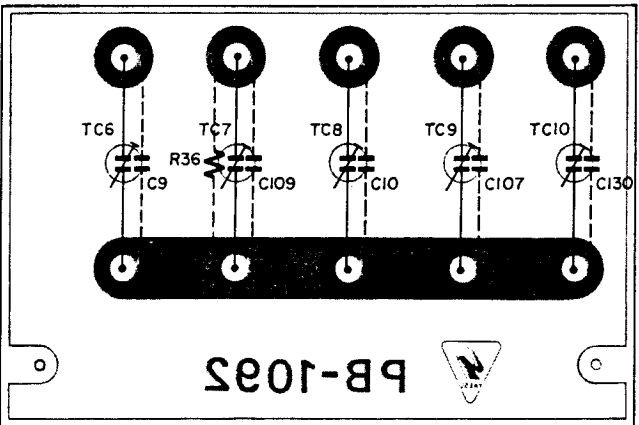

Viewed From Component Side

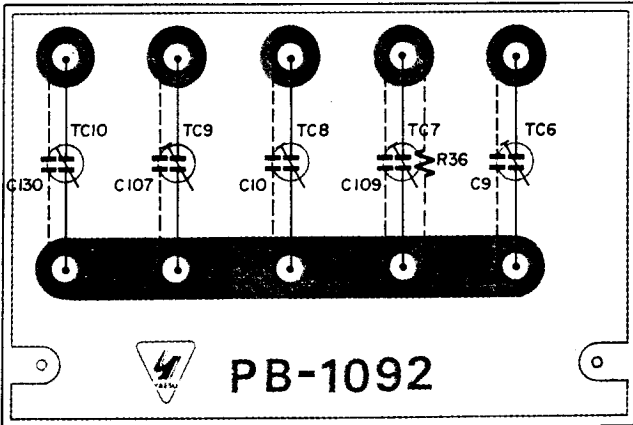

Viewed From Solder Side

ANTENNA TRAP BOARD PB-1116(A~Z)

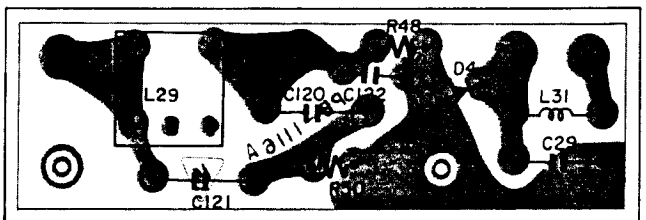

Viewed From Component Side

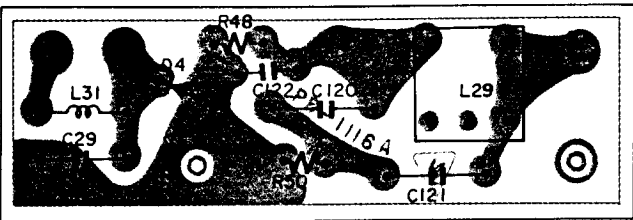

Viewed From Solder Side

**CRYSTAL BOARD PB-1073(A~Z)**

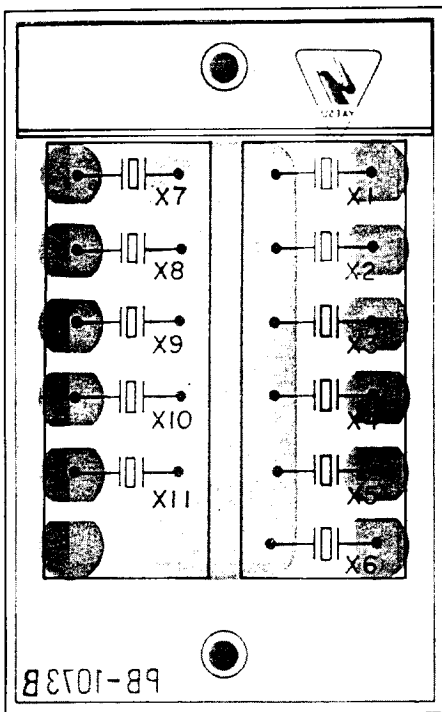

Viewed From Component Side

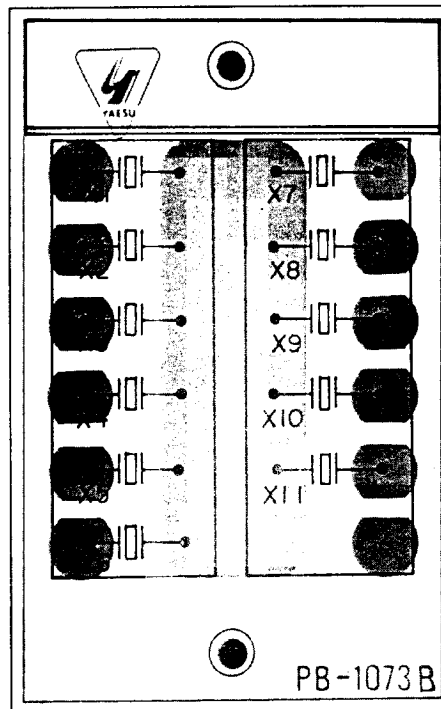

Viewed From Solder Side

For Service Manuals Contact  
**MAURITRON TECHNICAL SERVICES**  
 8 Cherry Tree Rd, Chinnor  
 Oxon OX9 4QY  
 Tel:- 01844-351694 Fax:- 01844-352554  
 Email:- enquiries@mauritron.co.uk

**RECTIFIER BOARD PB-1076B**

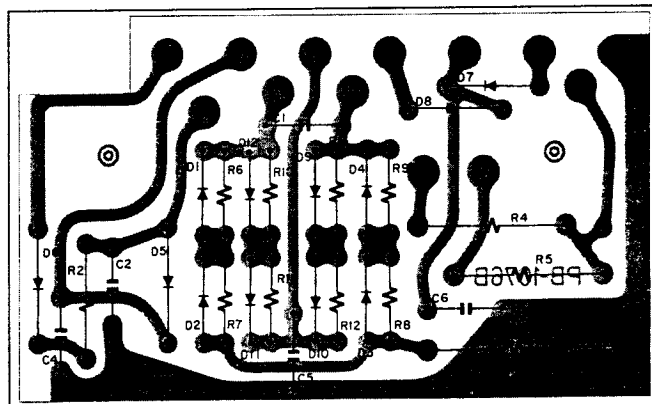
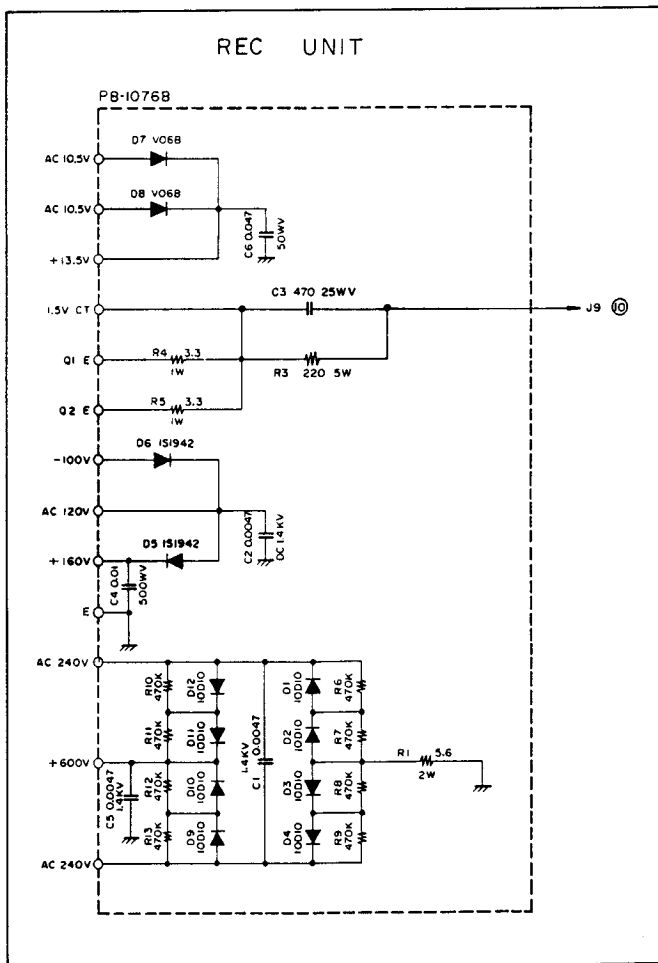

Viewed From Component Side

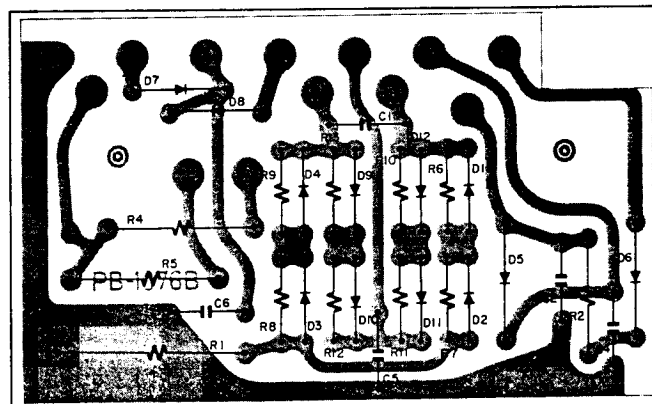

Viewed From Solder Side

# RECTIFIER UNIT

PB - 1076B

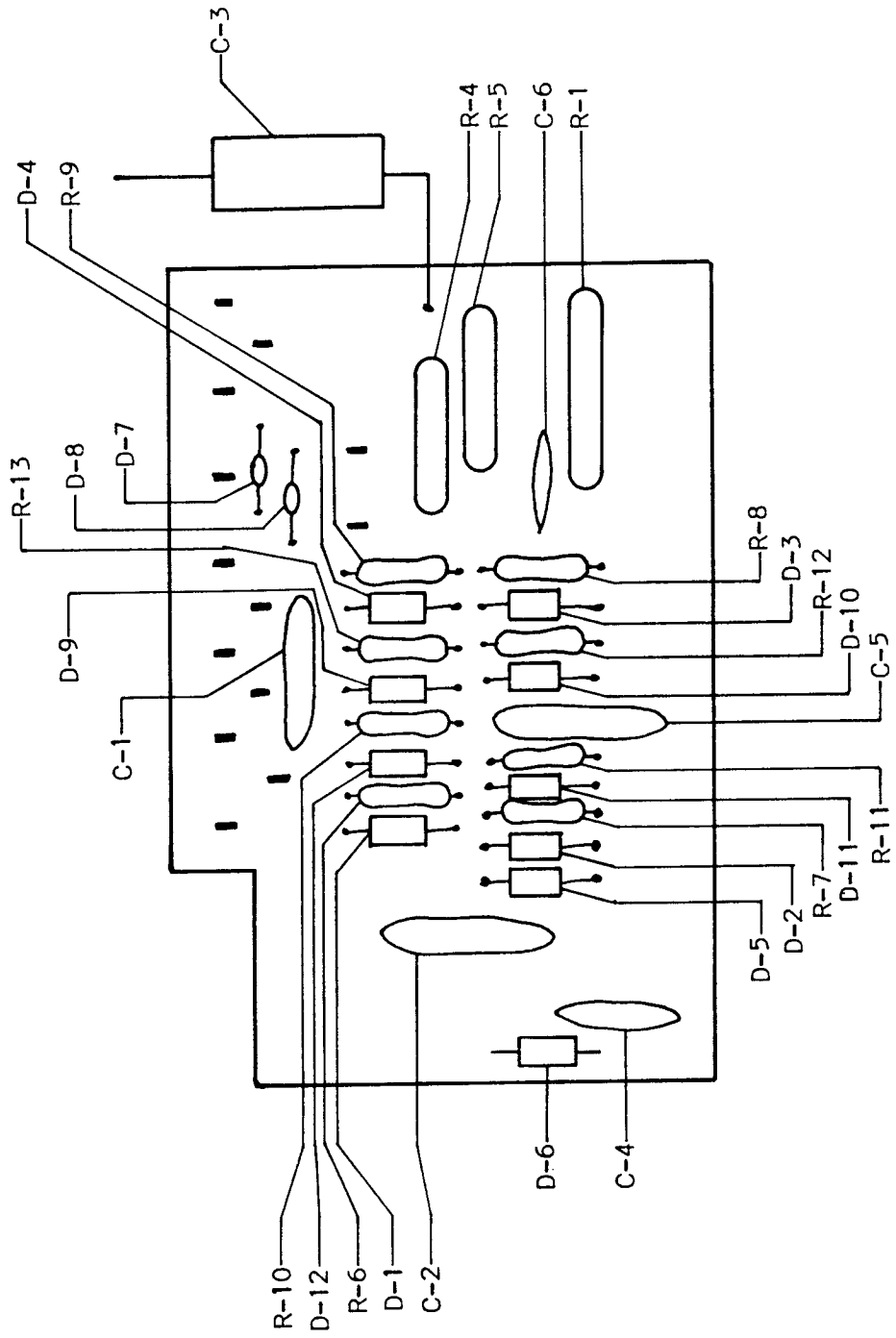

TRAP BOARD PB-1109(A~Z)

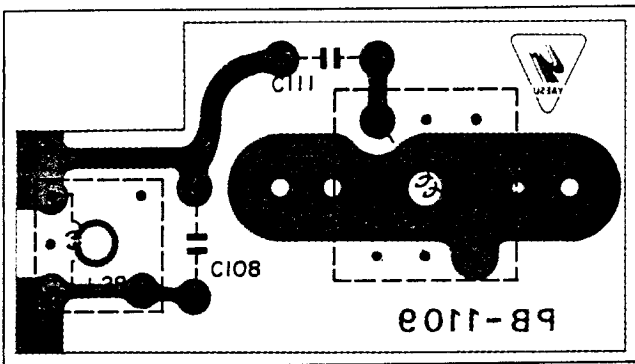

Viewed From Component Side

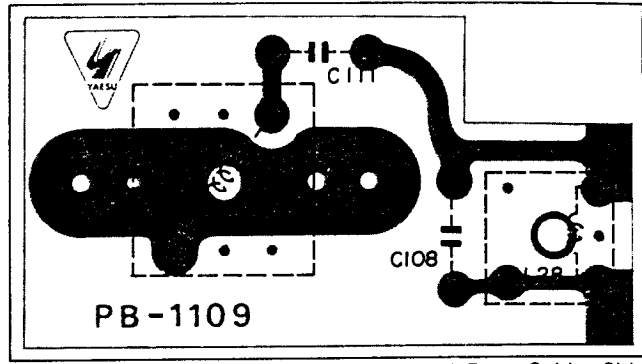

Viewed From Solder Side

COIL BOARD A PB-1083(A~Z)

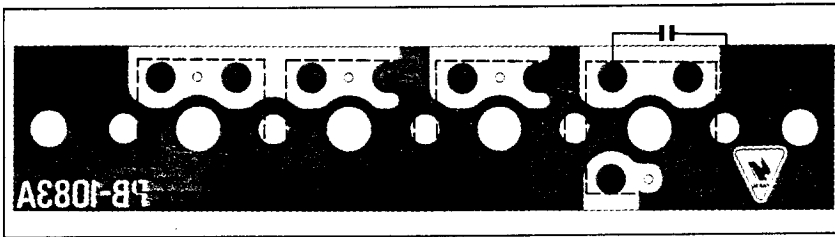

Viewed From Component Side

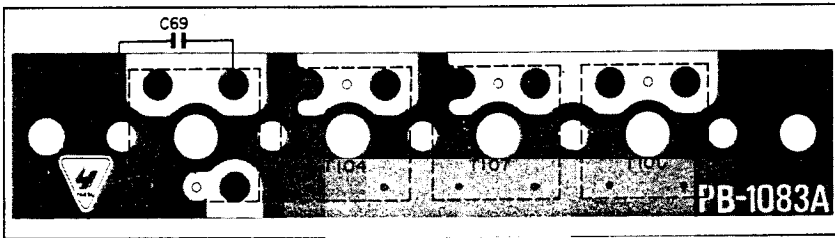

Viewed From Solder Side

For Service Manuals Contact  
**MAURITRON TECHNICAL SERVICES**  
 8 Cherry Tree Rd, Chinnor  
 Oxon OX9 4QY  
 Tel:- 01844-351694 Fax:- 01844-352554  
 Email:- enquiries@mauriton.co.uk

COIL BOARD E PB-1166(A~Z)

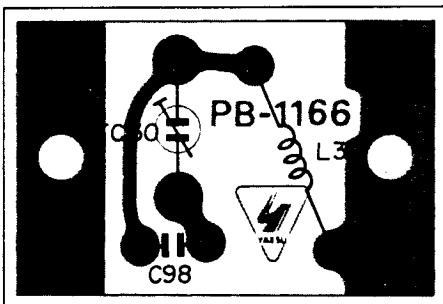

Viewed From Component Side

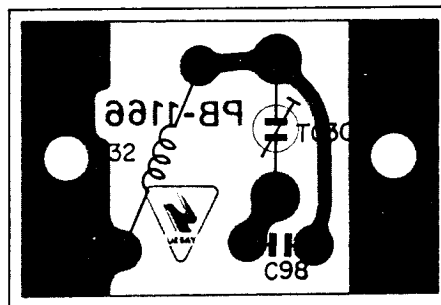

Viewed From Solder Side

DIODE SWITCH BOARD PB-1186(A~Z)

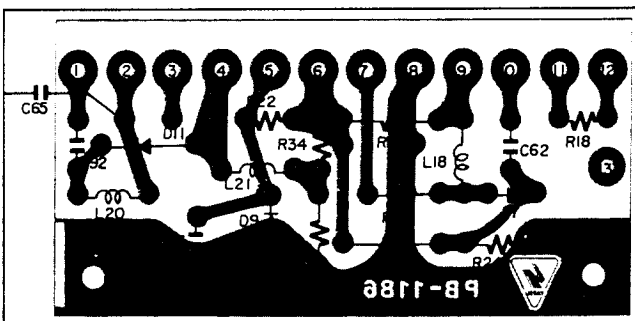

Viewed From Component Side

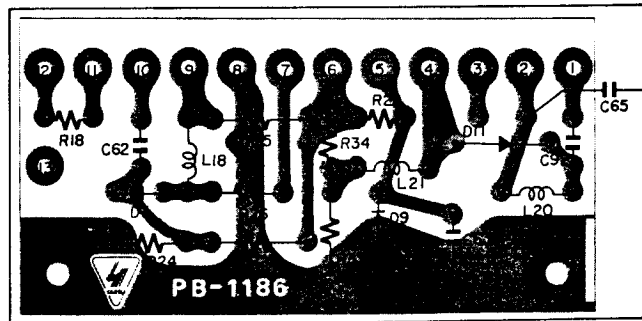

Viewed From Solder Side

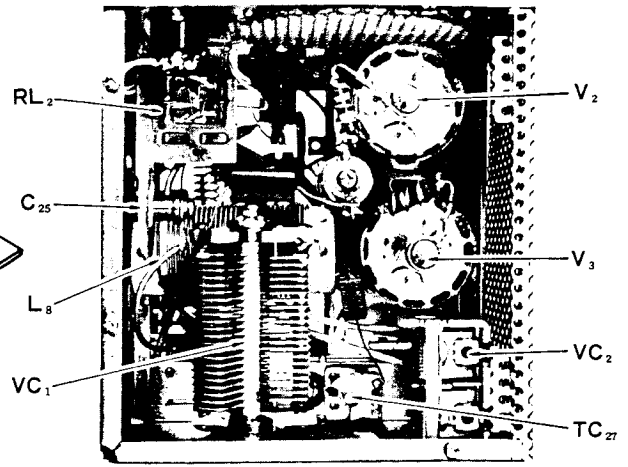
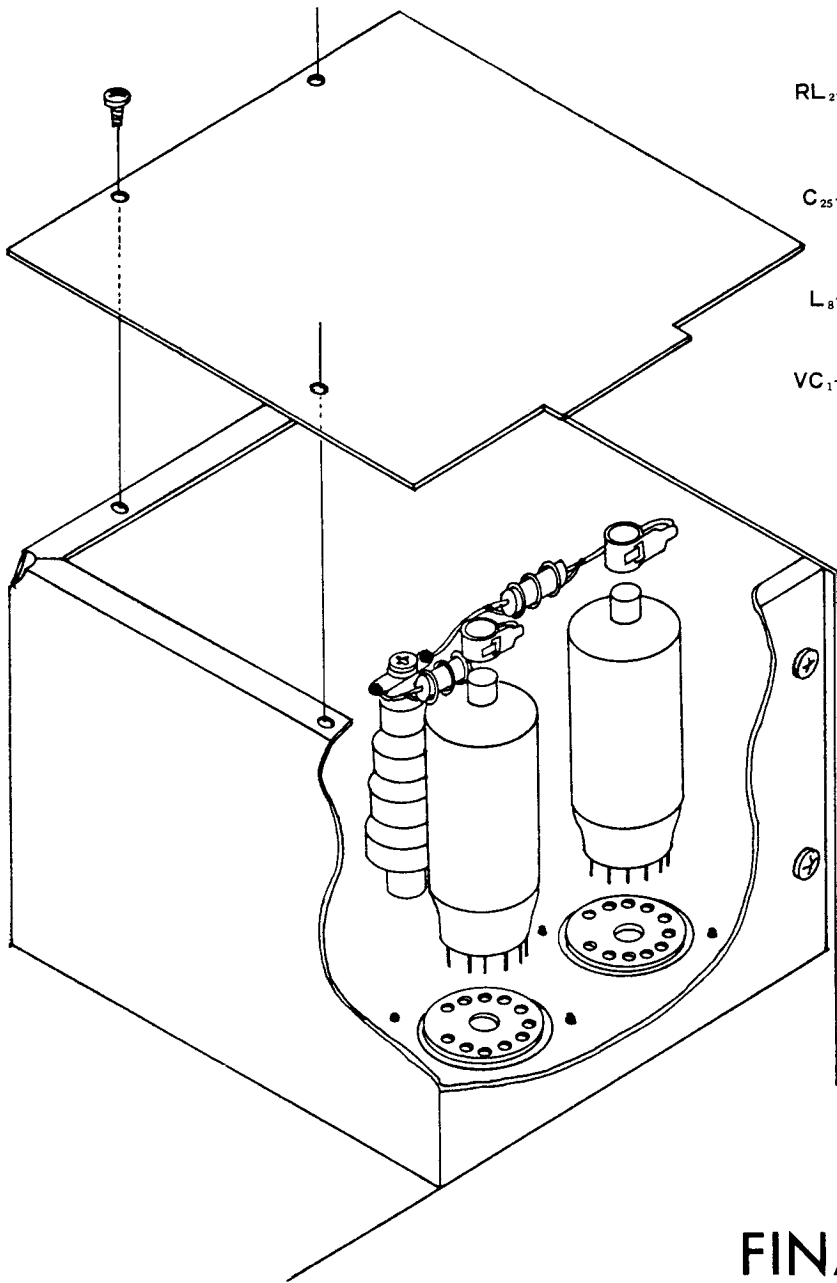

FINAL AMPLIFIER COMPARTMENT

# FINAL AMPLIFIER

CAUTION-HIGH VOLTAGE

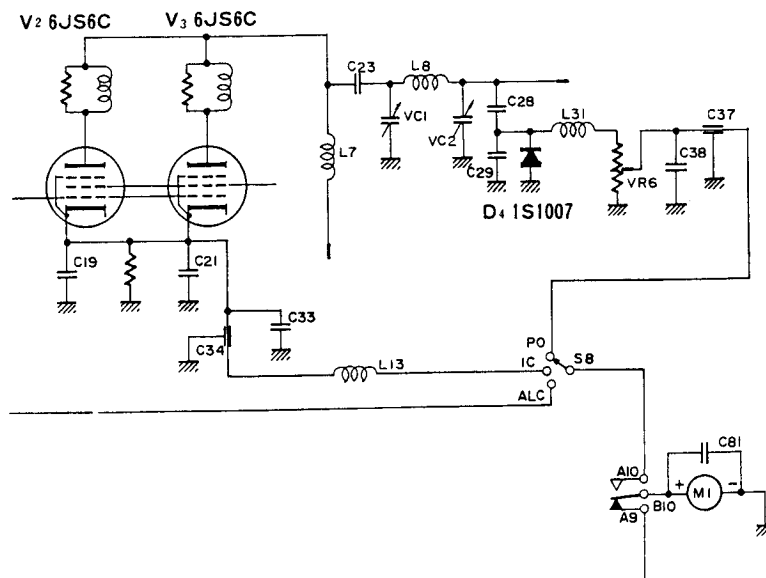



# MODIFICATIONS

## SECTION 6

CONTENTS	PAGE
INSTALLATION OF RF PROCESSOR TYPE B INTO EE/EX . . .	6-1
INSTALLATION OF RF PROCESSOR INTO LATE 101 AND B . .	6-12
CW FILTER INSTALLATION . . . . .	6-14
FT-101 SERIES (ALL) AM MODIFICATION . . . . .	6-16
FT-101EX DC-DC CONVERTER INSTALLATION . . . . .	6-17
HUM PROBLEMS IN EARLY FT-101 . . . . .	6-20
HUM PROBLEMS IN LATER FT-101B/E/EE/EX . . . . .	6-21
NOISE POP MODIFICATION . . . . .	6-23
MODIFIED FAN HOOKUP . . . . .	6-24
PB1582 NOISE BLANKER MODIFICATION . . . . .	6-25
FAN INSTALLATION FOR FT-101/FT-101B (220V FAN) . . .	6-26
FAN INSTALLATION FOR FT-101E/EE/EX (100V FAN) . . .	6-28
MODIFICATION FOR FSK OPERATION . . . . .	6-29
POWER TRANSFORMER CONNECTIONS . . . . .	6-30
MODIFICATION FOR NON-STANDARD FREQUENCIES . . . . .	6-31

**For Service Manuals Contact**  
**MAURITRON TECHNICAL SERVICES**  
8 Cherry Tree Rd, Chinnor  
Oxon OX9 4QY  
Tel: 01844-351694 Fax: 01844-352554  
Email: enquiries@mauritron.co.uk

INSTALLATION OF RF PROCESSOR TYPE "B"  
INTO FT-101EE/EX MODELS (PB1534)

Prior to starting installation, check the serial number of your transceiver. The method of installation is slightly different for rigs bearing serial numbers higher than '150001'. For rigs bearing serial numbers higher than '150001' only (a), (k) and (m) are required, since the balance of the parts are already mounted in place.

PARTS REQUIRED:

(a) FIX & RF Processor Printed Board, PB1534 assembly tested	- 1 ea.
(b) Potentiometer - 1K ohm B/10K ohm B, 16 mm	- 1 ea.
(c) Carbon Resistor - 10K ohm, 1/4 watt	- 1 ea.
(d) Knob, FT-25S, 3.5 mm	- 1 ea.
(e) Lever Knob "A"	- 1 ea.
(f) Coax Cable, Yellow, 1.5 D2V	- 45 cm
(g) Wire, White/Orange, 0.5 mm	- 60 cm
(h) Wire, White/Yellow, 0.5 mm	- 45 cm
(i) Wire, White, 0.5 mm	- 40 cm
(j) Wire, Black, 0.5 mm	- 25 cm
(k) Vinyl Tube, 3 mm	- 10 cm
(l) Vinyl Tube 1 mm	- 2 cm
(m) Harness Wire	-100 cm

PREPARATION:

1. Rotate two slot screws 90 degrees in CCW direction and remove the top cover.
2. Remove two 3 mm nuts, six self-tapping screws and two Phillips screws, remove the bottom cover.

3. Remove four self-tapping screws on the bottom side, two Phillips screws on both sides and three Phillips screws on the top side of the cabinet.
4. Slide the chassis and panel assembly from the cabinet.
5. Remove three Phillips screws as shown by ▲ marks in Fig. 6-1
6. Lift up the speaker boards and disconnect the speaker leads by unsoldering them.

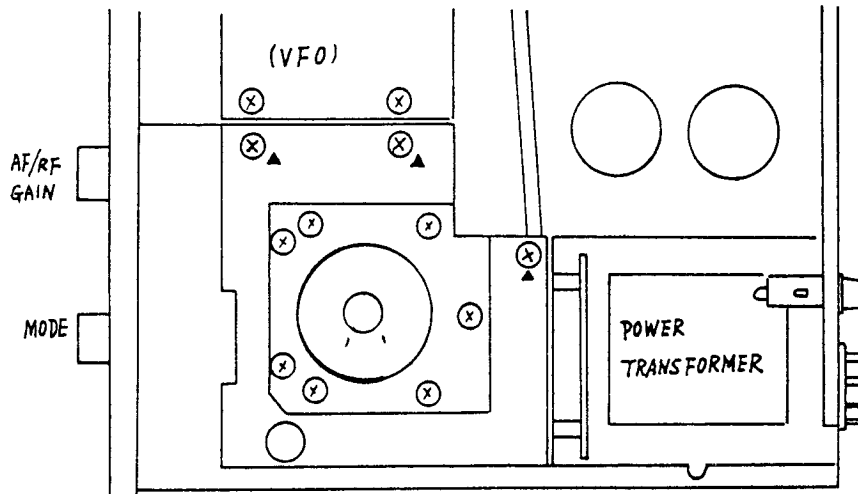

Fig. 6-1

## INSTALLATION

For units bearing serial numbers preceding '150000', the transceiver should be modified as follows:

### UNDER THE CHASSIS:

1. Disconnect the two white/yellow wires from Pin 11 of MJ-5. Connect and solder Pin 11 to pin 7 of MJ-5 with a 2.5 mm length of black colored wire.
2. Prepare the 45 cm length of white/yellow wire (h) supplied with the kit. Solder one end of this wire together with two white/yellow wires removed from Pin 11 by Step 1. Insulate the soldered point with 1.5 cm length of the 3 mm yellow tube.
3. Disconnect the white wire from Pin 14 of MJ-5 and solder it to one end of the 40 cm length of white wire supplied. Insulate the soldered point with 1.5 cm length of the 3 mm yellow tube.
4. Remove a wire between Pin 10 of MJ-3 and terminal board at the side of MJ-3. (See Fig.6-9)

5. Locate the unsoldered and insulated red coax cable at the side of MJ-3. Solder inner conductor of the red coax cable to Pin 10 of MJ-3. The yellow coax cable is not used and the end of it should be insulated by tubing.
6. Prepare the 45 cm length of yellow coax cable. Solder the inner conductor to the terminal of 6P terminal board from which the wire is removed by Step 4. Solder the outer conductor to the ground where the outer conductor of the red coax cable was soldered by Step 5. Please do the soldering work very carefully so as not to damage the coax insulator.
7. Lead the three wires soldered by Step 2, Step 3, and Step 6 above the chassis through an opening near the VFO gear.
8. Solder black (j) and white/orange (g) wires and 10K ohm resistor (c) as illustrated in Fig. 6-2.
9. Remove screw marked \* and loosen screw marked ▲ in Fig.6-3. Slide trimmer board toward arrow direction and lift. Locate the clarifier potentiometer and disconnect all soldering from the potentiometer with soldering iron. Remove knob and remove the potentiometer.

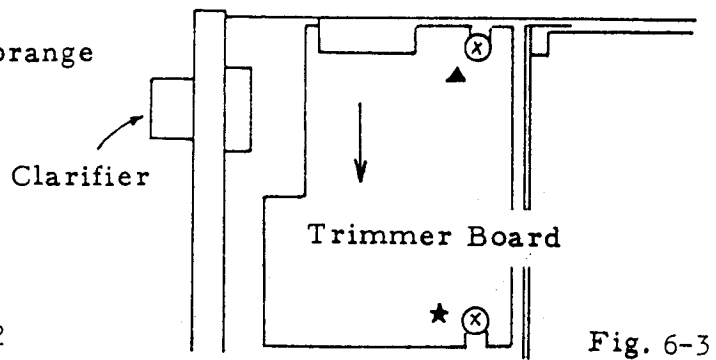
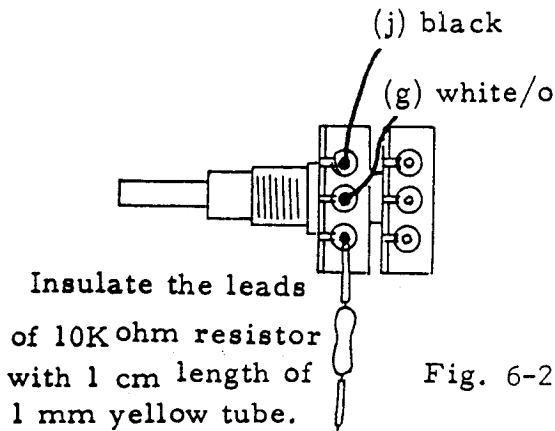

10. Install the new potentiometer soldered in Step 8. Resolder all wiring removed in Step 9 as illustrated in Fig.6-4. Solder the other end of the 10K ohm resistor to the terminal of clarifier switch where a white/brown wire is soldered.

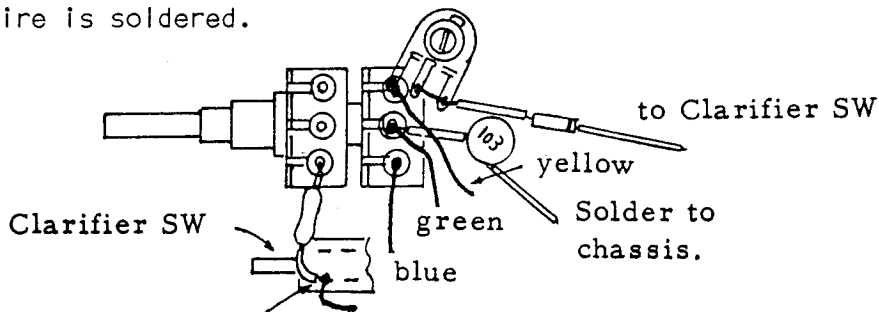

Terminal where white/  
brown wire is soldered

Fig. 6-4

11. Solder the other end of the black wire soldered to the potentiometer in Step 8 to the ground at coil board (PB1083A) as illustrated in Fig.6-5. The white/orange wire is led above the chassis from the opening near the VFO as illustrated. Bind the white/orange, white/yellow wires and yellow coax cable to wire harness with string supplied as illustrated.
12. Resolder speaker wires and reinstall the speaker board.

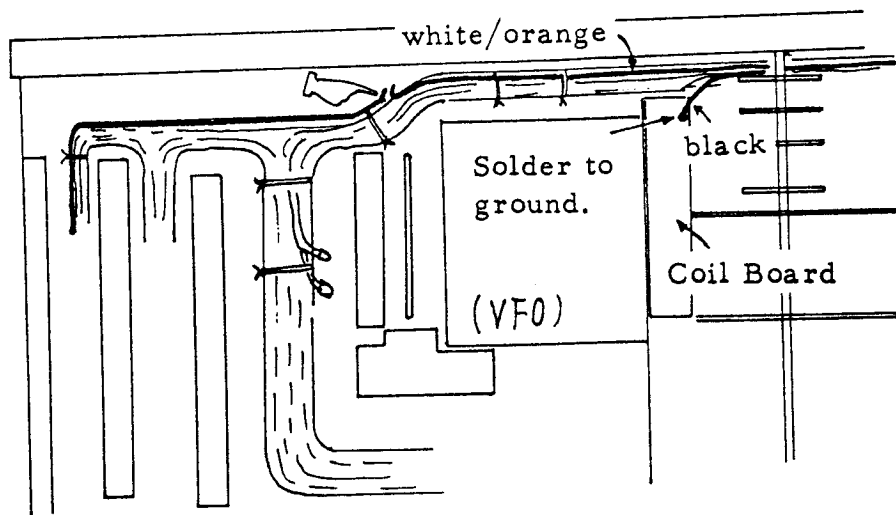
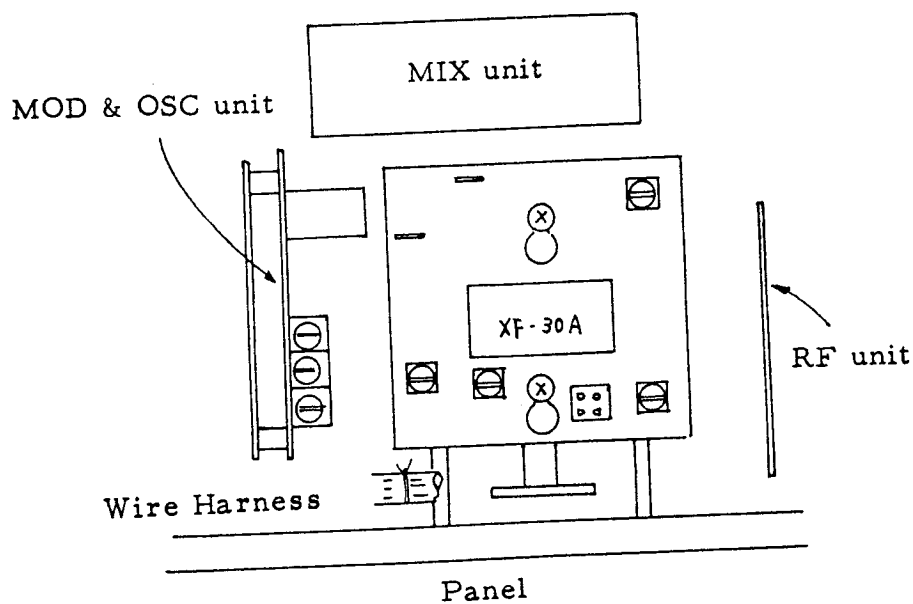

Fig. 6-5

ABOVE THE CHASSIS:

1. Remove a nylon clamp holding the wires at the top cover of the VFO unit. Bind these wires together with the wires which are brought above the chassis from the opening near the VFO unit as illustrated in Fig.6-6. The yellow coax cable is not used, therefore, cut it as short as possible.



2. Install the RF processor unit on the VFO unit using the screw removed in Step 1 (UNDER THE CHASSIS instructions).
3. Solder all wires as illustrated in Fig.6-7. There are two kinds of same colored wire, i.e. white/red and white/brown. These wires are from the VFO select switch as underlined in the illustration.
4. Tighten the clarifier/level potentiometer so that lever and knob travel equally for both sides as illustrated in Fig.6-8. Set the knob and lever supplied.
5. Replace the trimmer board temporarily removed in Step 9 (UNDER THE CHASSIS instructions).
6. Carefully check to see that the wiring is correctly done.

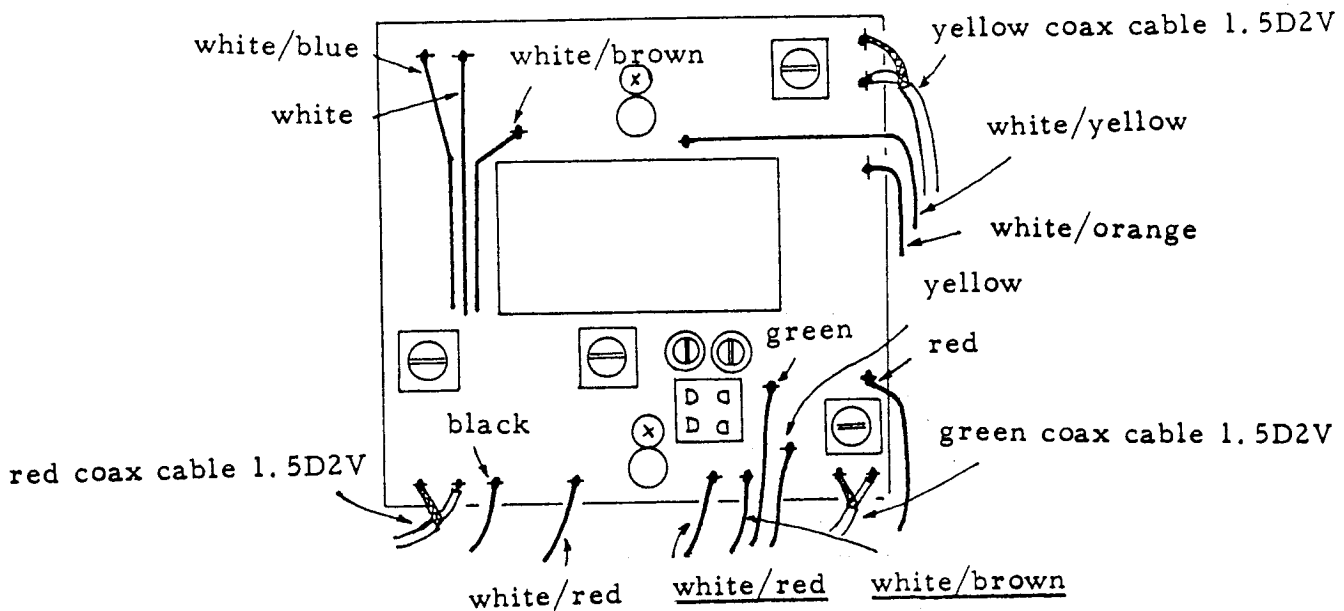

Fig. 6-7

For Service Manuals Contact  
**MAURITRON TECHNICAL SERVICES**  
 8 Cherry Tree Rd, Chinnor  
 Oxon OX9 4QY  
 Tel:- 01844-351694 Fax:- 01844-352554  
 Email:- enquiries@mauritron.co.uk

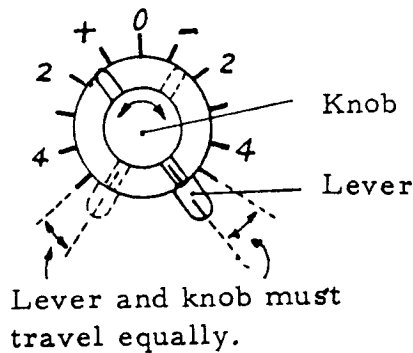

Fig. 6-8

## INSTALLATION

For units bearing serial numbers higher '150001', prior to installation of the RF processor, the transceiver should be modified by the following steps:

### UNDER THE CHASSIS:

1. Remove the jumper wire between Pin 10 of MJ-3 and 6P terminal board (X mark in Fig. 6-9).
2. Locate the unsoldered red and yellow coax cable between MJ-3 and chassis wall. Solder inner conductors as illustrated in Fig. 6-9.
3. Re-install the speaker board.

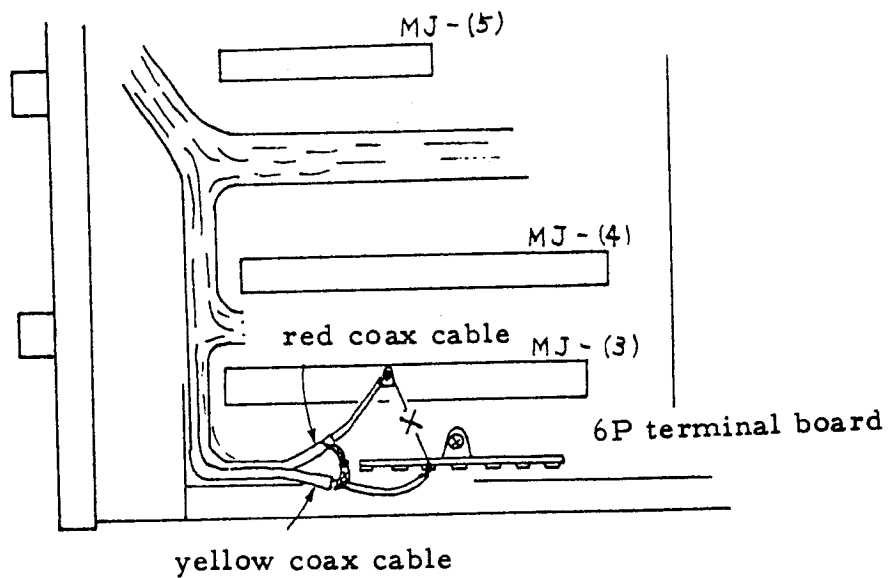

Fig. 6-9

ABOVE THE CHASSIS:

1. Remove a nylon clamp holding wires at the top cover of the VFO unit.
2. Remove a black tube from the wires. Red, white, white/yellow and white/grey wires are soldered together. Separate all wires. The white wire is not used and the end of it should be insulated by tubing.
3. Mount the RF processor board as illustrated in Fig. 6-6.
4. Wire as illustrated in Fig.6-10. Underlined wires are from VFO select switch and the others are from the wire harness.

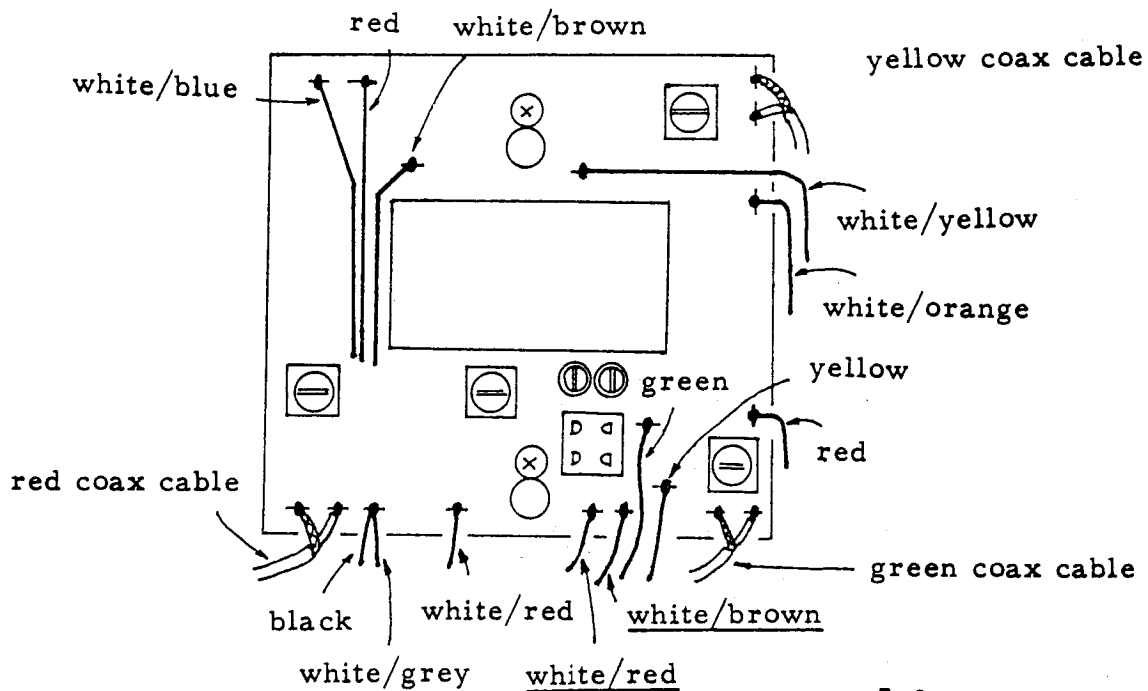

Fig. 6-10

For Service Manuals Contact  
MAURITRON TECHNICAL SERVICES  
8 Cherry Tree Rd, Chinnor  
Oxon OX9 4QY  
Tel:- 01844-351694 Fax:- 01844-352554  
Email:- enquiries@mauritron.co.uk



## ALIGNMENT

### Resistance Check:

Prior to applying power to the transceiver, check the wiring. Set the controls and switches as follows and measure the resistance between various check points and ground.

MOX VOX PTT SW . . . . . PTT  
 VFO SELECT SW . . . . . INT  
 CLARIFIER CONTROL . . . . . 0  
 MODE SW . . . . . USB or LSB  
 LEVEL CONTROL . . . . . FULLY CW POSITION  
 PROC SW . . . . . OFF  
 METER SW . . . . . IC  
 CLAR SW . . . . . OFF

Table 1 shows resistance value when measured at various test points shown in Fig.6-11. (Minus lead of the circuit tester connected to ground).

When meter indications exceed the values shown by more than 10%, re-check your wiring.

Test Point		Test Point	
(A)	0	(J)	1K
(B)	∞	(K)	250 (90)
(C)	0	(L)	8
(D)	160 (55)	(M)	160K
(E)	∞	(N)	0 (5K)
(F)	∞	(O)	62 (2.5K)
(G)	0	(P)	600 (3.4K)
(H)	0	(Q)	1K
(I)	∞	(R)	0

TABLE 1

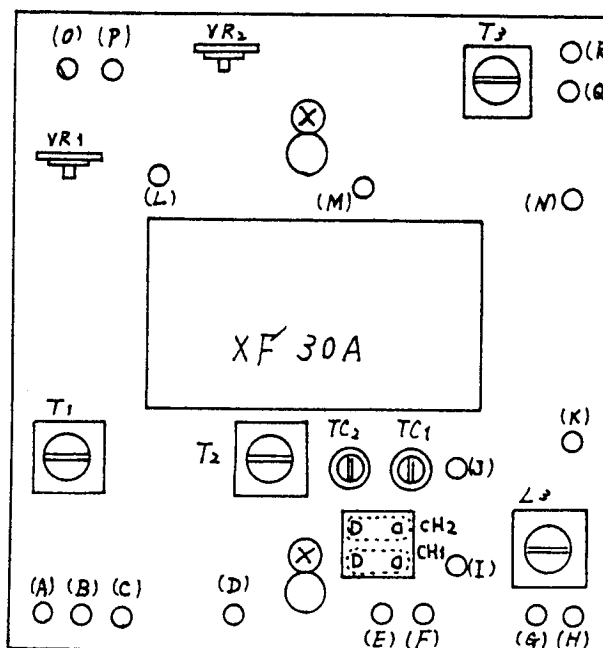

Fig. 6-11

- \* At test point (D) the plus lead of VTVM is connected to ground. Value of 55 ohms is measured with PROCESS switch "ON".
- \* At test point (K) a 90 ohm value is measured when VFO SELECT SW is at Ch 1 or Ch 2.
- \* At test point (N) a 5K ohm value is measured when LEVEL control is at a fully CCW position.
- \* At test point (O) the plus lead of VTVM is connected to ground. Value of 2.5K ohms is measured with PROCESS switch "ON".
- \* At test point (P) a 3.4K ohm value is measured when METER SW is at ALC position.

VOLTAGE CHECK:

Apply power to the transceiver. Measure the following voltages at the indicated check points:

Check Point (L) + 13 Volts

Check Point (K) + 6 Volts with VFO SELECT SWITCH on Ch 1 and Ch 2 positions -0 volts on other positions.

Check Point (N) 0 Volts with LEVEL control at fully clockwise position and + 6.75 volts at fully counter clockwise position.

Values were measured by using a 20K ohms/volt Voltmeter.

For transceivers bearing serial numbers lower than "150000", the clarifier zero set potentiometer, VR4 should be realigned as described in the Instruction Manual, on page 16.

ALIGNMENT:

The RF Processor Kit is completely checked and tested at the factory prior to shipment. The following test procedure may be of help to you if the controls are moved by mistake.

Set the controls and switches as follows:

POWER	- ON	MODE	- USB or LSB
HEATER	- OFF	METER	- ALC
PROCESSOR	- OFF	MIC GAIN	- "0" fully CCW position

1. Set function switch to MOX position, then adjust VR2 on the processor board until the meter indicates full scale.
2. Connect RF probe of VTVM to check point (B) in Fig.6-11. Apply 1 kHz signal at 10 mv to the microphone input. Adjust MIC GAIN control for 30 mv VTVM reading.
3. Set VR1 to the center of its range. Connect the RF probe of your VTVM to check point (Q). Peak T1 and T3 for maximum indication of VTVM. Set VR1 for 30 mv VTVM reading.
4. Set the processor switch to "ON" position and peak T2 for a maximum output.

#### HOW TO OPERATE THE RF PROCESSOR

1. Set the meter switch to ALC and RF processor switch to "OFF" position. Speak into the microphone in a normal tone, and adjust the MIC GAIN control so that the meter indication does not exceed the green portion on voice peaks.
2. Set the RF processor switch to "ON" position. Set the LEVEL control so that the ALC indication does not exceed the green portion on the voice peaks.
3. Excessive setting of the MIC GAIN will decrease S/N ratio of the transmitted signal.

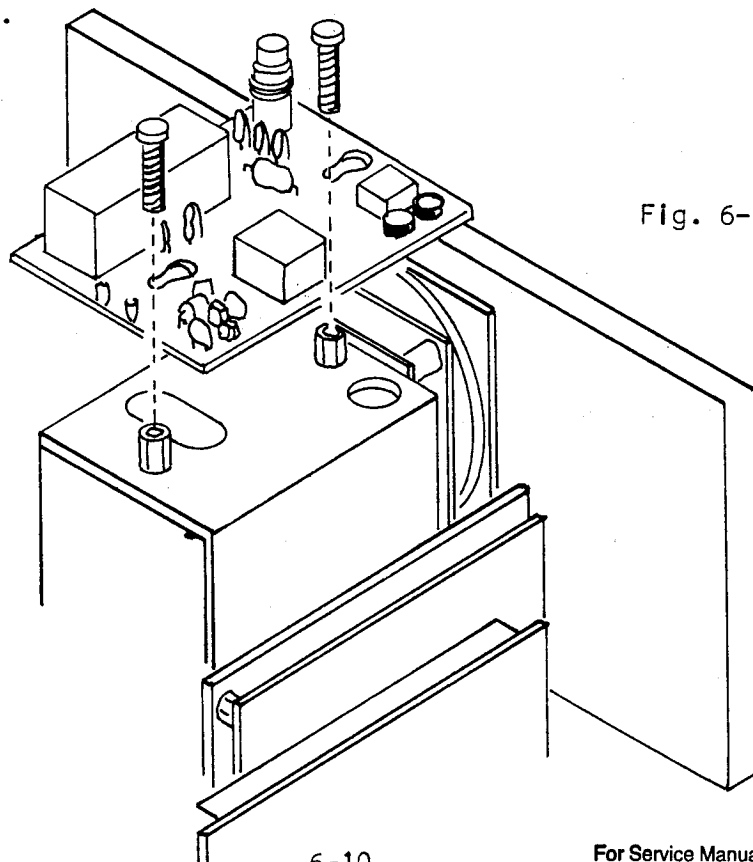

Fig. 6-12

For Service Manuals Contact  
**MAURITRON TECHNICAL SERVICES**  
 8 Cherry Tree Rd, Chinnor  
 Oxon OX9 4QY  
 Tel:- 01844-351694 Fax:- 01844-352554  
 Email:- enquiries@mauritron.co.uk

RF SPEECH PROCESSOR  
INSTALLATION INTO LATE FT-101 AND FT-101B

PARTS REQUIRED:

- (1) Lug type terminal strip (6-32 mount hole)
- (2) RF-174 miniature coax cables, 21" long
- (2) Plastic insulated hookup wire, #22 solid or stranded, 21" long
- (1) Diode (1S1555) minimum rated 13.5v at 50ma
- (1) Insulated tubing, 3" long, 1/2" ID - PVC or shrink tube
- (1) SPDT switch (optional)
- (1) PB1494 Speech Processor board

Strip and pre-tin the two hookup wires, 1/2 inch on each end. Strip and pre-tin the two coax cables, so you have 1/4 inch of center conductor bare, 3/4 inch center conductor insulated and a 1 inch braid pigtail.

Remove the top cover and locate the VFO unit. Install the processor board as shown in Fig. 6-12.

If a yellow/white wire is present between MJ-3 pin 10, and this point, clip it out and discard it. (Fig. 6-14) The RF signal is now going to move up from pin 10 of MJ-3, through the first new coax, into the processor "IN" lug, get processed, and return down the second new coax to lug 3. If you get into trouble, this is where you use your scope to check it out.

The jumper, of course, just moved the signal straight across to lug 3, so if you get absent minded and leave that jumper in place, the processor will act the same, in or out.

Now hook up the rest of the wires as shown in Fig. 6-13, be neat and be careful soldering. No overheating, cold joints or solder splashes.

Strip and solder one end of a 21" length of hookup wire to the "OFF" lug of the processor. (In the FT-101EE or EX, this is a white/blue wire already in the bundle, so you do not need to add an extra wire).

Route the free end down under the chassis and dress it toward socket MJ-6, that's the one holding the regulator board. Locate T12, using Fig. 6-15 to help you orient yourself. Mount the new terminal strip under the mounting screw of T12 that is nearest the center of the chassis.

Wire up the PB1494 as shown in Fig.6-13, dressing the wires neatly in formed bundles, as shown.

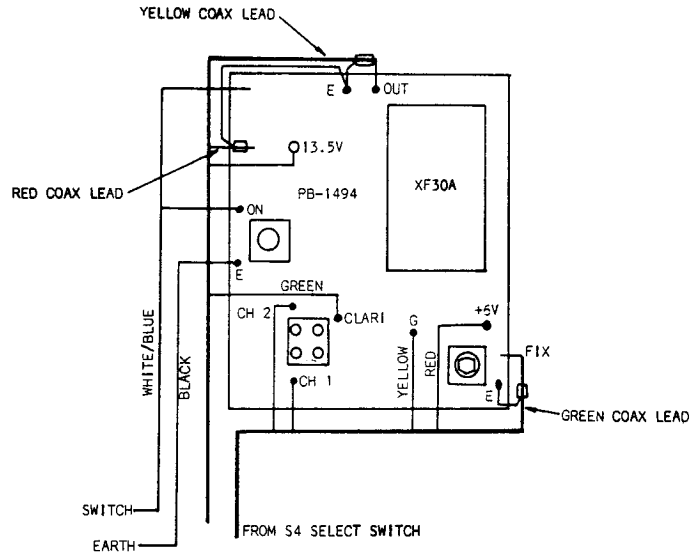

FIG. 6-13

Begin by soldering one coax center conductor to the "IN" terminal of PB1494, and its braid to "E".

Locate the green coax coming from the select switch (S-4) and solder it to the "fix" terminal, shield to the adjacent "E" point. You may have to tug the wire up a bit from the bundle, but it will reach okay.

Route the free end of your first coax along the board edge, then down through the space between chassis opening and panel, along the wiring harness to MJ-3 (IF unit socket) solder the center conductor to pin 10 of MJ-3, and the shield to pin 13.

Solder the second piece of new coax to the board, center conductor to "out", shield to "E". Dress the free end parallel to the other new coax, and terminate it on the lug type terminal, center conductor to lug 3 of the terminal strip just below MJ-3 socket, and parallel to it as shown in Fig.6-14. This is the junction of R19, R20 and D8, if you need more orientation.

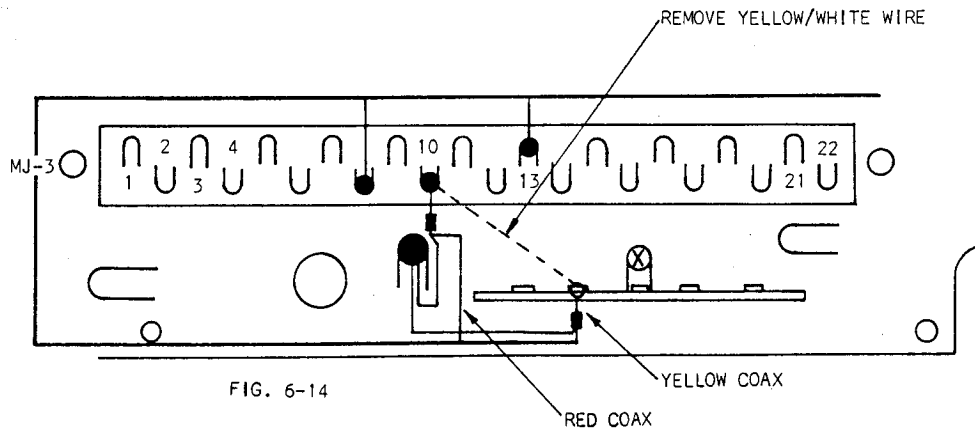

FIG. 6-14

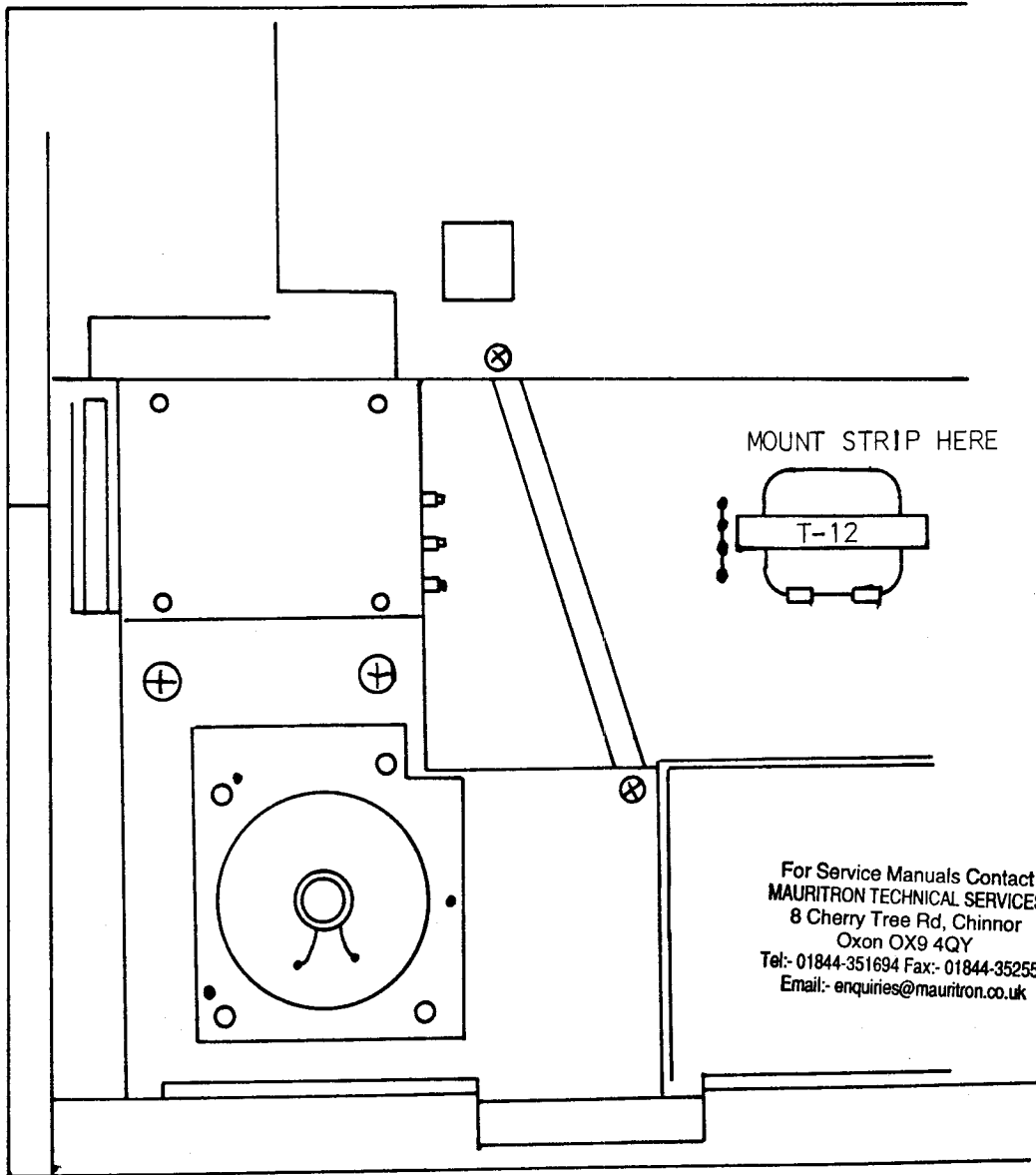

FIG. 6-15

Now locate pin 9 of MJ-6. You will see a wire extends and connects to a three lug terminal strip where a diode is terminated. Solder the 1S1555 diode's cathode (banded) end to where the wire extension to the terminal strip is made. The anode of the diode is connected to the new terminal strip. Connect the free end of your hookup wire that you attached to the "OFF" lug at the beginning of this exercise, and solder it to the lug the 1S1555 anode is connected to.

Take the remaining piece of hookup wire, strip the ends 1/4 inch and solder one end to +13 on the processor board. Route it down through the chassis to pin 19 of MJ-3, and solder the free end there.

The processor is now "in" at all times, so to allow you to switch it in and out at will, an extra switch must be installed. Many owners stop right here, and just leave it in the circuit at all times.

No "extra hole" is available for a switch, so some ingenuity on the part of the owner is necessary, unless he has no qualms about drilling a new hole in the panel.

One suggestion is to mount the switch to the shield at PB1104, which leaves it accessible and looks neat.

Wire the SPDT switch so that the anode of the 1S1555 diode can be switched between the "OFF" and "ON" lugs of the PB1494.

Open the hookup wire you installed earlier (the first one) that runs between the "OFF" lug and the anode of the new 1S1555 diode, and solder the anode side to the switch common, the board "OFF" lug side to one side of the switch, and then run another (3rd) piece of hookup wire between the other side of the switch and the "ON" lug of the processor board.

Recheck your assembly, and test for operation, adjusting it as required for the different bands.

#### CW FILTER INSTALLATION

1. Remove top cover of transceiver cabinet and locate printed circuit boards PB1315A and PB1183B.
2. Remove two screws holding PB1315A to the U-shaped bracket. Remove two screws holding the U-shaped bracket to the shield plate, located between the two boards.
3. Remove PB1315A from the chassis connector receptacle. Gently, rock the circuit board out of the connector.
4. Remove the two screws holding the shield plate and lift out of the cabinet.
5. Grasping the U-shaped brackets still attached to PB1183B, gently rock the circuit board out of the connector.

6. With PB1183B removed from the chassis, remove C10 and C9 (.01 uF) capacitors from board. Install XF-30C CW filter in position indicated using the nuts and lockwashers provided. Solder the four filter terminals to the board.
7. Re-install PB1183B into socket, screw shield plate to chassis, and re-install PB1315A into socket. Replace all attaching screws.

This completes the CW filter installation. The filter provides a 600 Hz bandpass when the mode switch is placed in the CW position. Transceiver realignment is not required for this installation.

For Service Manuals Contact  
**MAURITRON TECHNICAL SERVICES**  
 8 Cherry Tree Rd, Chinnor  
 Oxon OX9 4QY  
 Tel:- 01844-351694 Fax:- 01844-352554  
 Email:- enquires@mauritron.co.uk

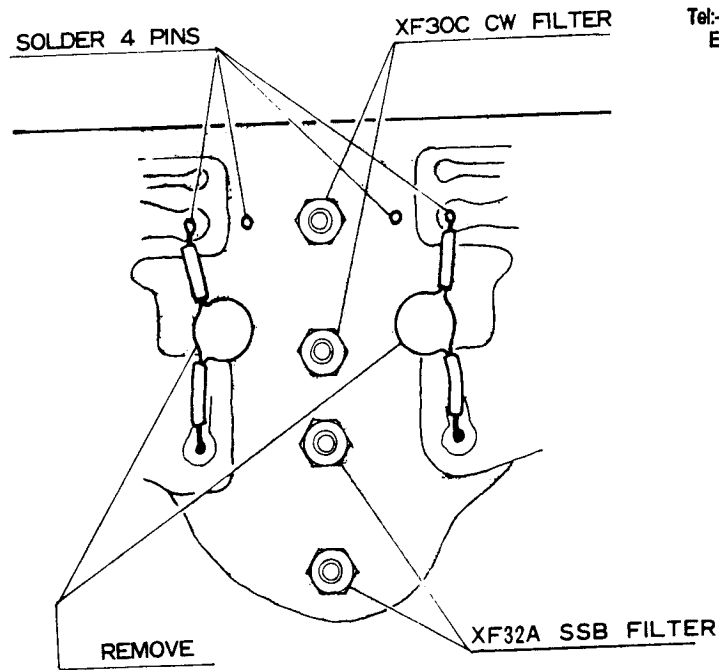

Fig. 6-16

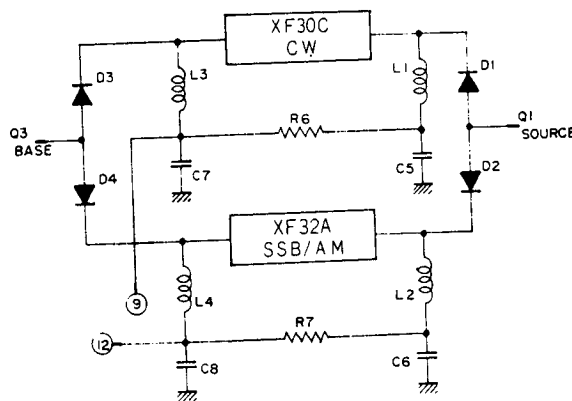

Fig. 6-17

CW FILTER INSTALLATION DIAGRAM



FT-101 AM MODIFICATION

Install AM filter in the CW filter position. Wire mode switch S2C as follows:

1. Remove the jumper between pins 1 and 5.
2. Remove the banded end of diode D1 from pin 5 and solder it to pin 4.
3. Solder a jumper from pin 3 to pin 2.
4. Remove the yellow wire at pin 9 of MJ-3 which goes to the heater switch SSB and solder it to pin 4 of S2C.
5. Remove the yellow wire from pin 4 of S2C and solder it to pin 5 of S2C.
6. Remove the red wire from pin 1 of S2C and solder it to pin 1 of mike connector J3.

This completes the AM filter modification. The set will operate normal in the LSB and USB modes and will use the SSB filter in the CW mode. The wide band AM filter will be switched into the circuit when the mode switch is placed in the AM position and the SSB filter will be switched out of the circuit. The only change from normal operation will be in the TUNE-CW modes. The mike pre-amp and amplifier stages will be turned on if the VOX switch is in the VOX position. Audio can not be transmitted in the CW mode even though the VOX relay can be energized via the mike, but in the TUNE mode audio can be transmitted if the mike gain is turned up.

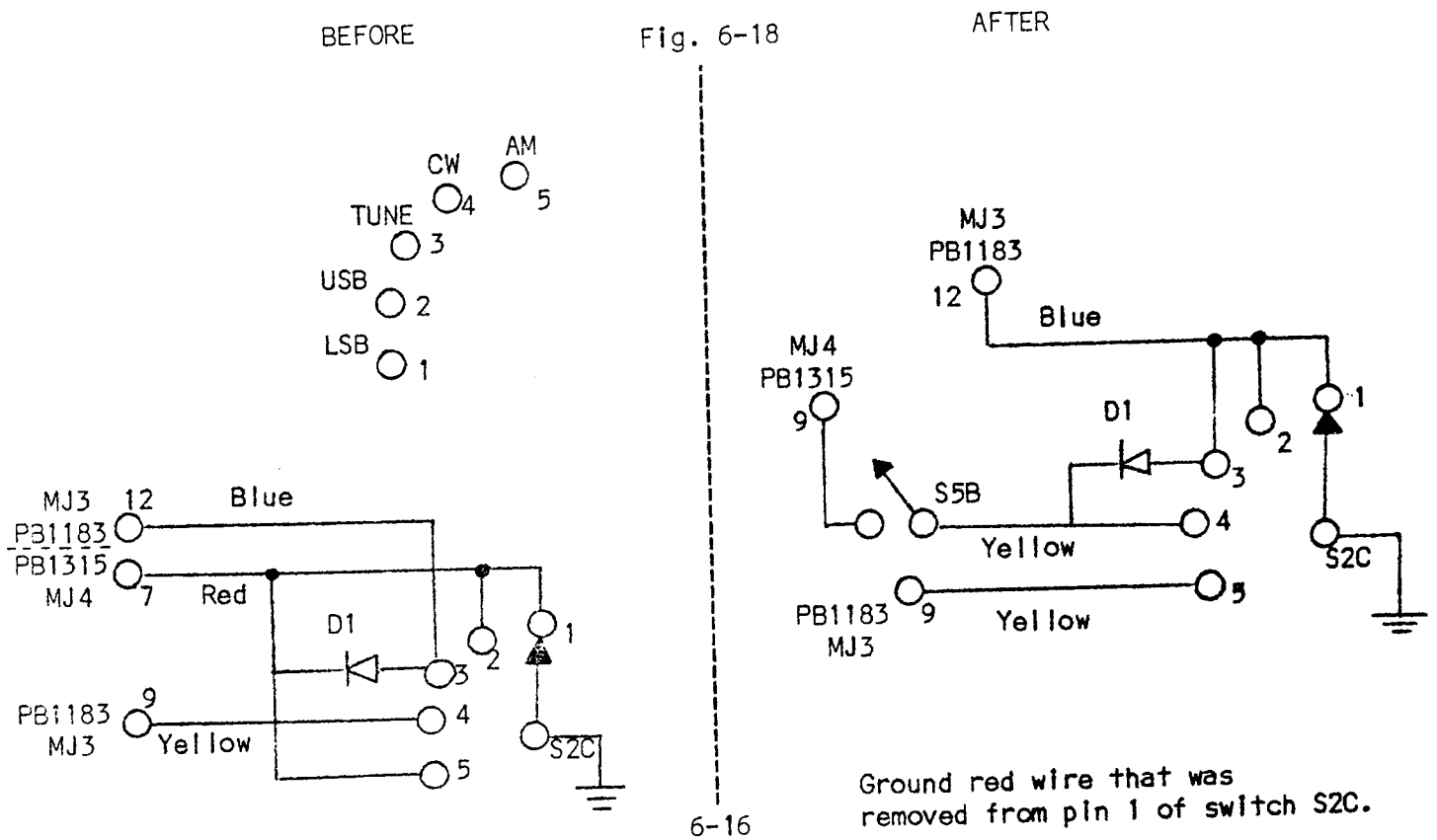

## FT-101EX DC-DC CONVERTER INSTALLATION

For installation of DC-DC converter, base and collector wires have already been wired into the power supply in the FT-101EX, and are terminated (and insulated) in a sleeve on the rear of the transceiver. The converter kit will allow DC operation of the transceiver, with the appropriate line cord.

### PARTS REQUIRED:

- (2) . . . . Transistors (2N4280, 2SB206 or 2SB212)
- (1) . . . . Heat Sink
- (1) . . . . Heat Sink Cover
- (2) . . . . Heat Sink Clamps
- (4) . . . . Screws M3 x 25
- (4) . . . . Flat Washers M3
- (4) . . . . Spring Washers M3
- (1) . . . . DC Cable (With 12 pin square plug)
- (2) . . . . Fuses 20 Amp
- (4) . . . . Tapping Screws M3 x 6
- (1) . . . . Insulator 1429A
- (1) . . . . MP Condenser 0.47 uF 60V

For Service Manuals Contact  
**MAURITRON TECHNICAL SERVICES**  
8 Cherry Tree Rd, Chinnor  
Oxon OX9 4QY  
Tel:- 01844-351694 Fax:- 01844-352554  
Email:- enquiries@mauritron.co.uk

### INSTALLATION:

1. Remove the nylon clamp from the back panel, and slip off the vinyl tube from the wires.
2. Take the protection paper off from the 1429A insulator and stick the insulator to the back panel, as shown in Fig.6-19.
3. Screw the heat sink spacers onto the back panel as illustrated in Fig.6-19, using the self tapping screws provided.
4. Wrap and solder the wires coming from the back panel to each transistor as shown in Fig.6-20. Make sure each wire is soldered well, but do not overheat the transistors.
5. Use the four screws M3 x 25 and washers to install the heat sink and its cover onto the spacer, folding the wires gently into loops. Do not pinch or crush them while assembling the unit.
6. Change the AC power cord to DC power cord.

**CAUTION**

If using 2SB206's, leave out the 0.47 $\mu$ f capacitor - you don't need it. Wire as shown in Fig.6-20 or below.

If using 2SB212's, use a 2.2 $\mu$ f instead of the 0.47 $\mu$ f capacitor. Wire as shown in Fig.6-20 or below.

If using 2N4280's, use the 0.47 $\mu$ f capacitor, and wire as shown in Fig.6-20 or below:

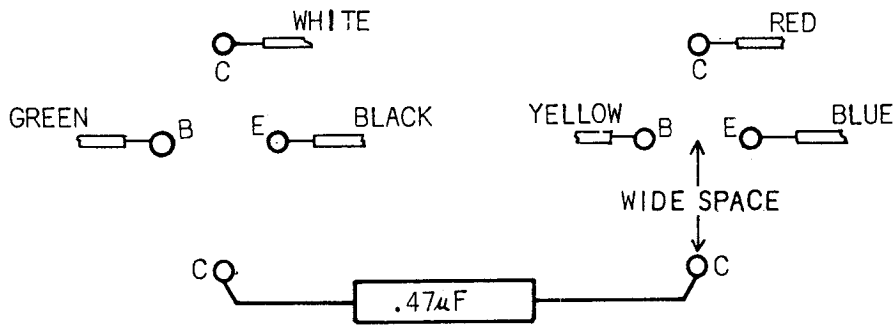

DC TEST

1. Both power and heater switches off initially.
2. Connect the DC power cord to either a 12 volt battery or a 13.5 volt power unit, connecting the red cord to the (+) side and the black cord to the (-) side of the battery.
3. Turn the power switch on. Advance the AF GAIN switch. Then make sure that the receiver is in normal operation. Use your calibrator signal to check it out.
4. Turn the heater switch on, ensure the DC-DC converter works and the fan motor runs. Should the fan motor not function, reverse the yellow and green wire connections for the proper polarity.
5. It is normal to hear a faint audible "singing" of the converter when it is functioning.

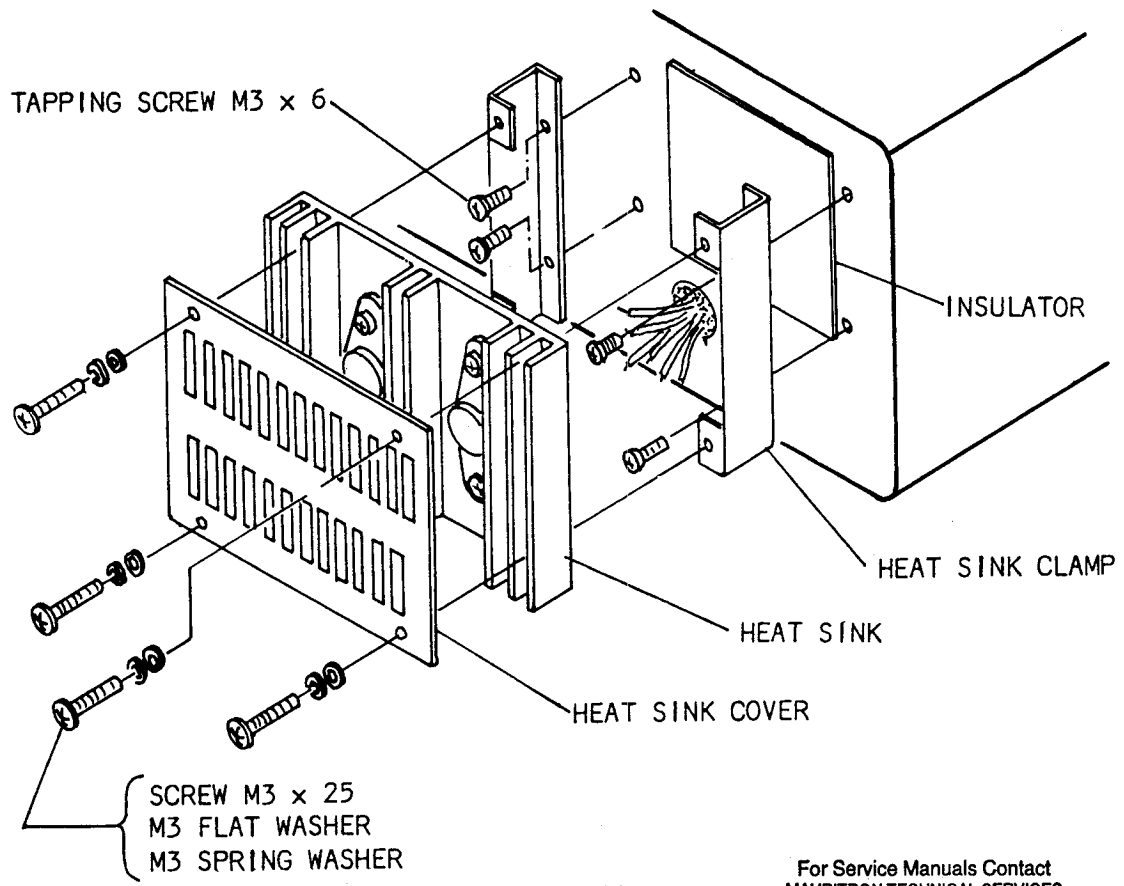

FIGURE 6-19

For Service Manuals Contact  
MAURITRON TECHNICAL SERVICES  
8 Cherry Tree Rd, Chinnor  
Oxon OX9 4QY  
Tel:- 01844-351694 Fax:- 01844-352554  
Email:- enquiries@mauritron.co.uk

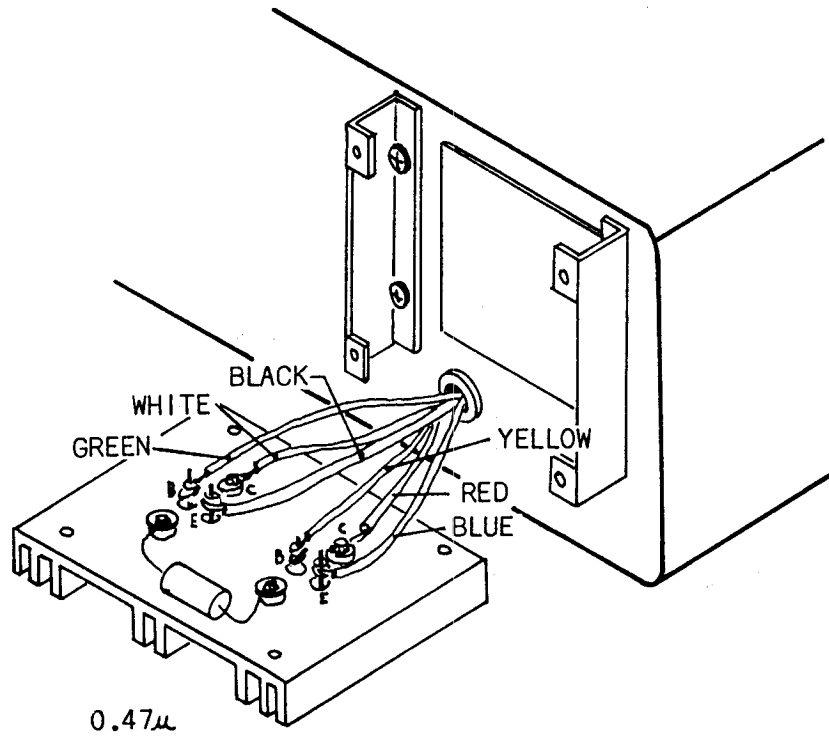

FIGURE 6-20

## HUM PROBLEMS IN EARLY FT-101

Occasionally, a seemingly incurable hum problem arose in older model FT-101 with serial numbers approximately between 006400 and 058000. (We don't know the exact beginning and end of this problem).

The hum usually appeared on both receive and transmit. It was not bad filtering or a defective component, it was caused by a ground loop and the fix was applied to PB1079, the voltage regulator/calibrator board, which in later FT-101's became the PB1185.

If you encounter this problem, it is a fairly straight forward solution. The drawings below illustrate the back of the board (solder side) and represent only the lower right hand one-fourth of the board with the plug facing the bottom of the page.

Using an artists knife or other suitable tool, isolate the small section of ground plane as shown in the illustration. Nothing additional should be done to this, as it has a ground on the other side of the board. Then clean up the solder connection which is indicated in the drawing. Get it smoothed off so you can drill right through the board and remove this connection completely. The front and back ground planes are connected at this point and the connection must be removed. Drill right through the center of the connection with about a number 36 drill.

If you have done it right and completely, the hum should be gone when you check your work.

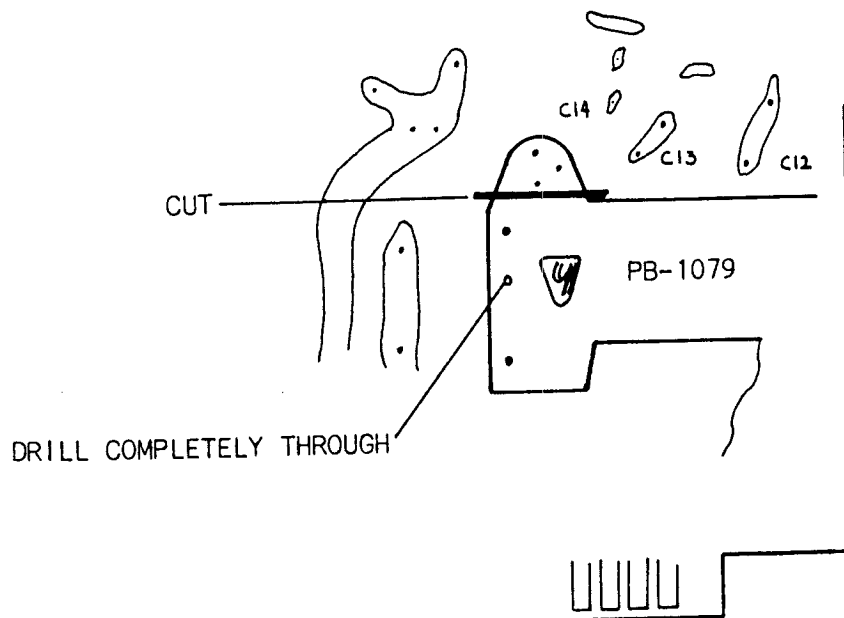

Fig. 6-21

## HUM PROBLEMS IN LATER FT-101B/E/EE/EX

The most common cause of hum is rosin on the contacts of the PB1315 audio board. If cleaning the contacts with alcohol does not resolve the problem, a second source of hum may be in pickup from the pilot lamp circuit. The cure is fairly simple, but you will have to modify this circuit; so remove the top and bottom covers.

1. Locate the two brown wires connected to the center pilot light, and clip the one brown wire going down (toward the chassis). Insulate the cut end and push it out of the way.
2. Solder a 5.6 ohm, 3 watt resistor between the left pilot light socket and the heater switch. (See Fig. 6-22).
3. Add a 1000 uF, 25wv between T12 and ground, as shown in Fig. 6-23.

Replace the covers and check it for hum level. It should not be greater than 10mv, with the volume control at minimum.

For Service Manuals Contact  
MAURITRON TECHNICAL SERVICES  
8 Cherry Tree Rd, Chinnor  
Oxon OX9 4QY  
Tel:- 01844-351694 Fax:- 01844-352554  
Email:- enquiries@mauritron.co.uk

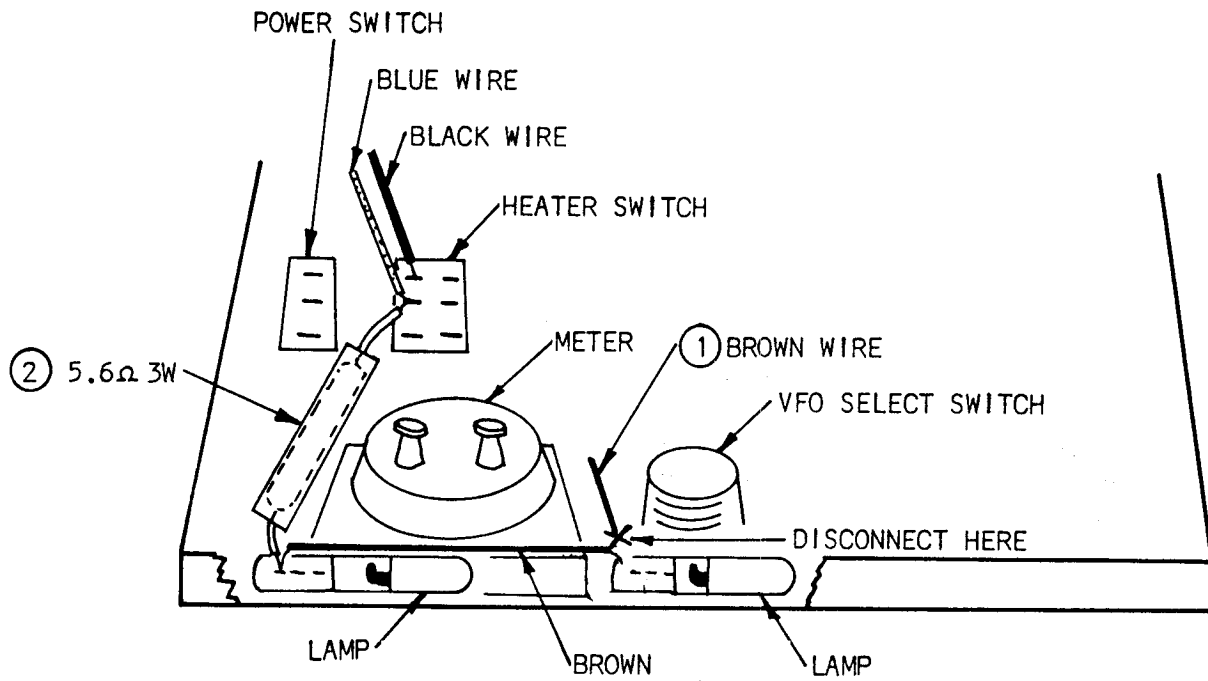

FIGURE 6-22

For Service Manuals Contact  
**MAURITRON TECHNICAL SERVICES**  
 8 Cherry Tree Rd, Chinnor  
 Oxon OX9 4QY  
 Tel: 01844-351694 Fax: 01844-352554  
 Email: enquiries@mauritron.co.uk

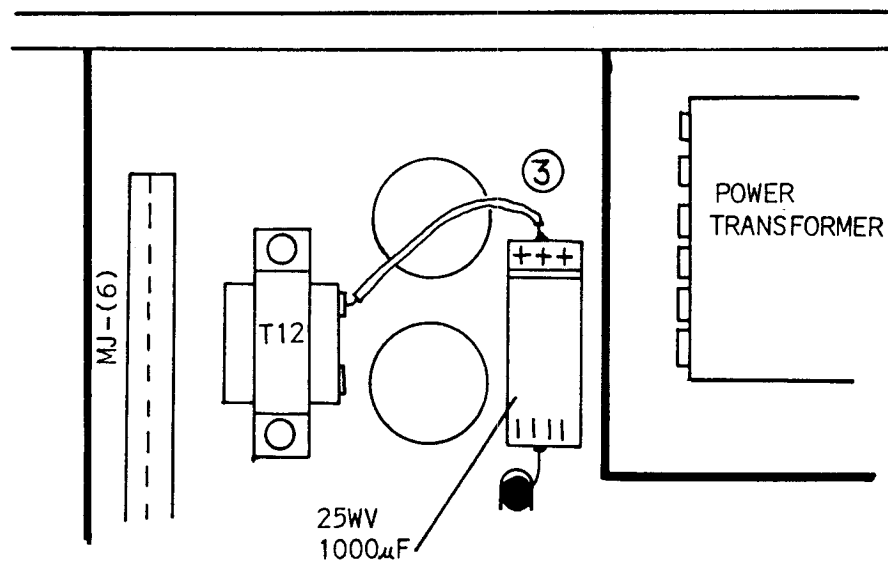

FIGURE 6-23

MODEL FT-101 ( )

PROBLEM: Loud pop when returning to receive mode

IF UNIT MODIFICATION (PB1183)

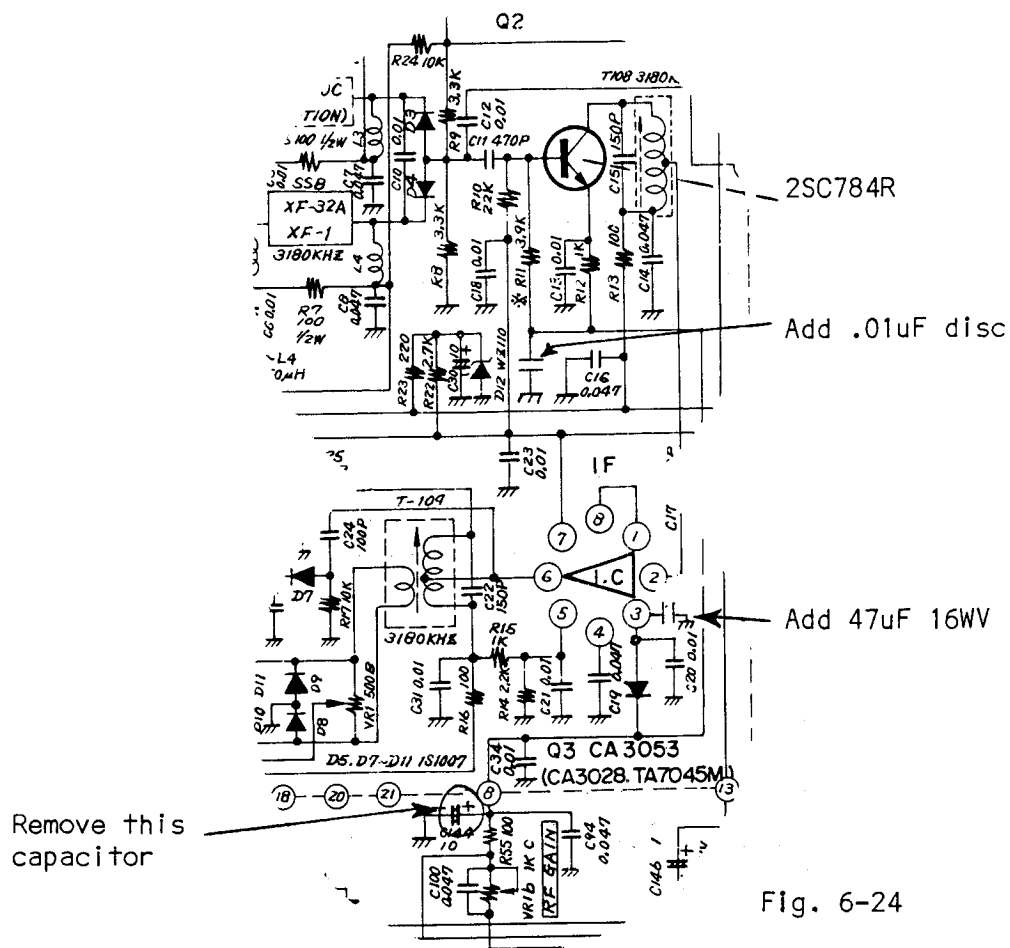

Fig. 6-24

The above modification to FT-101( ) IF module achieves limiting of noise pulses created in some units during the transition from transmit to receive and vice versa.



# MODIFIED FAN HOOK UP

## FT-101-B/E

FAN NO. FC75B

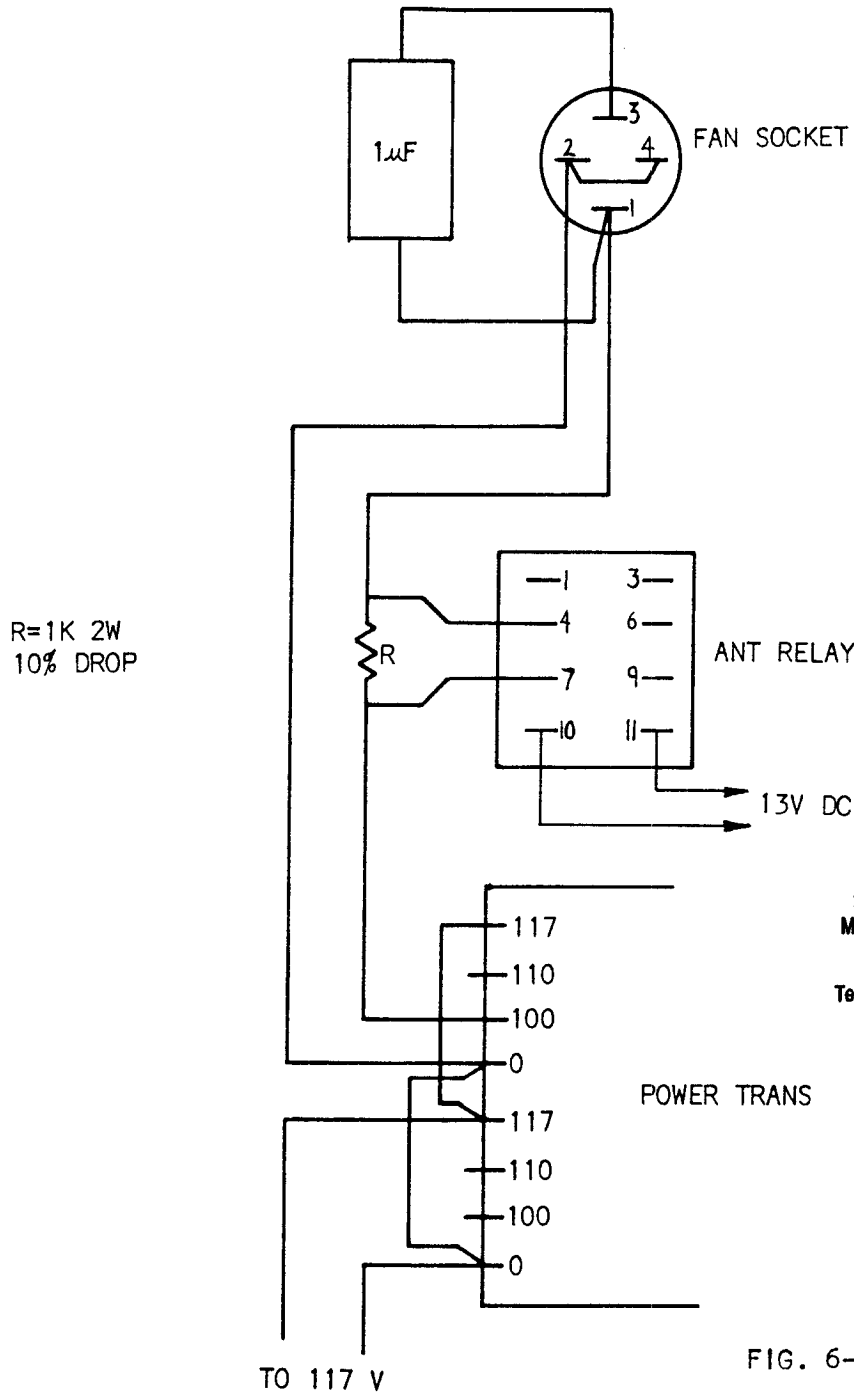

For Service Manuals Contact  
**MAURITRON TECHNICAL SERVICES**  
 8 Cherry Tree Rd, Chinnor  
 Oxon OX9 4QY  
 Tel:- 01844-351694 Fax:- 01844-352554  
 Email:- enquiries@mauritron.co.uk

FIG. 6-25

Note: Fan will operate only when transmitting.

# MODIFICATION

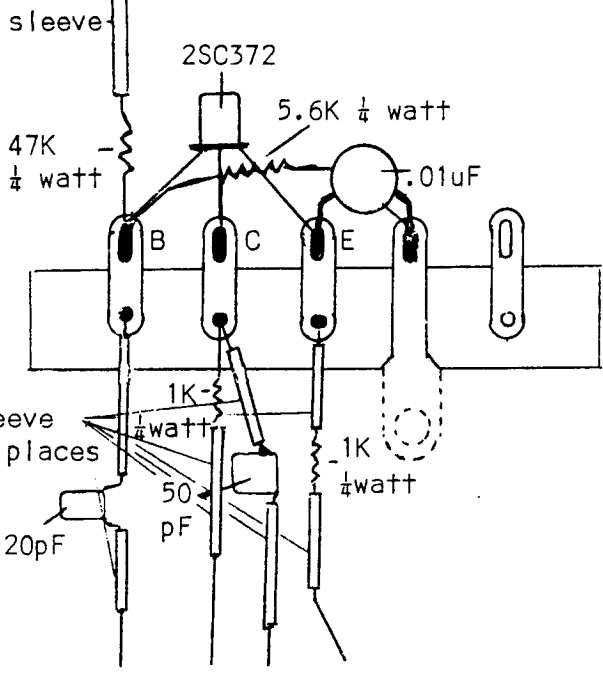

FIG. 6-26

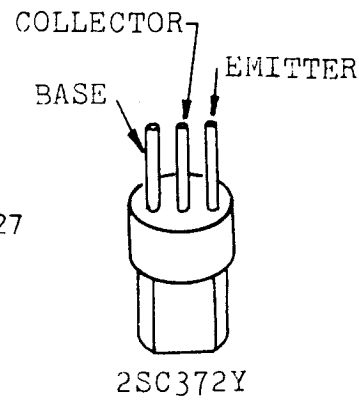
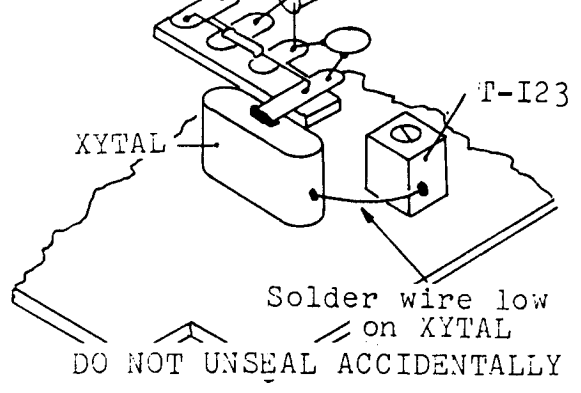

FIG. 6-27

2SC372Y

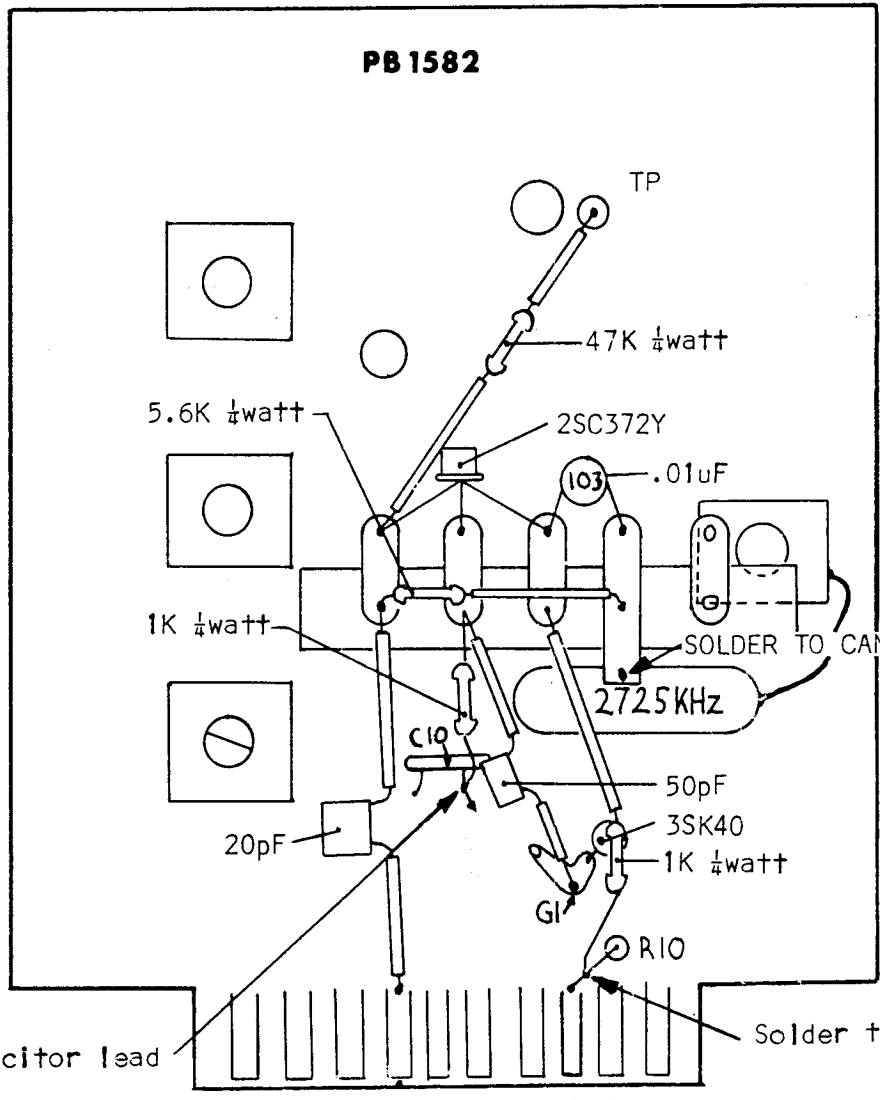

FIG. 6-28

Solder to capacitor lead

Solder to resistor lead

1 2 3 4 5 6 7 8 9 10

FAN INSTALLATION FOR FT-101/101B  
(220V FAN)

PARTS REQUIRED:

(1)	Fan Motor Assembly, FC-75-B	1 ea.
(2)	MP Capacitor, 1 uF 220VAC (none pola)	1 ea.
(3)	Plug, 4 pin	1 ea.
(4)	Packing	1 ea.
(5)	Washer	8 ea.
(6)	Screw, M3 x 10	4 ea.
(7)	Insulating Tube, 1 m/m	10 cm
(8)	Insulating Tube, 4 m/m	20 cm

INSTALLATION

1. Capacitor

For Service Manuals Contact  
**MAURITRON TECHNICAL SERVICES**  
8 Cherry Tree Rd, Chinnor  
Oxon OX9 4QY  
Tel:- 01844-351694 Fax:- 01844-352554  
Email:- enquiries@mauritron.co.uk

Open a top cover of the transceiver. Then remove 3 screws on the top cover of final compartment. Remove top cover of the final compartment and locate a socket on rear panel. Use 1 m/m insulating tube for capacitor leads and solder the capacitor as illustrated in Fig. 6-29.

INSIDE REAR PANEL

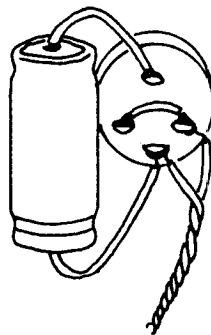

FIG. 6-29

## 2. Power Plug

Insert four wires into 4 m/m insulating tube. Solder these four wires to the plug supplied as illustrated in Fig. 6-30.

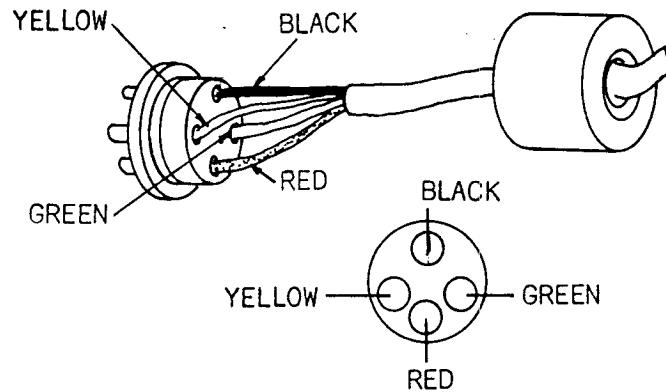

FIG. 6-30

## 3. Fan Motor

Remove four screws from a slit cover on the final compartment of rear panel. Install the fan into the hole as illustrated in Fig. 6-31.

Insert the power plug into the socket. The fan will activate when the power switch is turned on for AC operation, and when both power and heater switches are turned on for DC operation

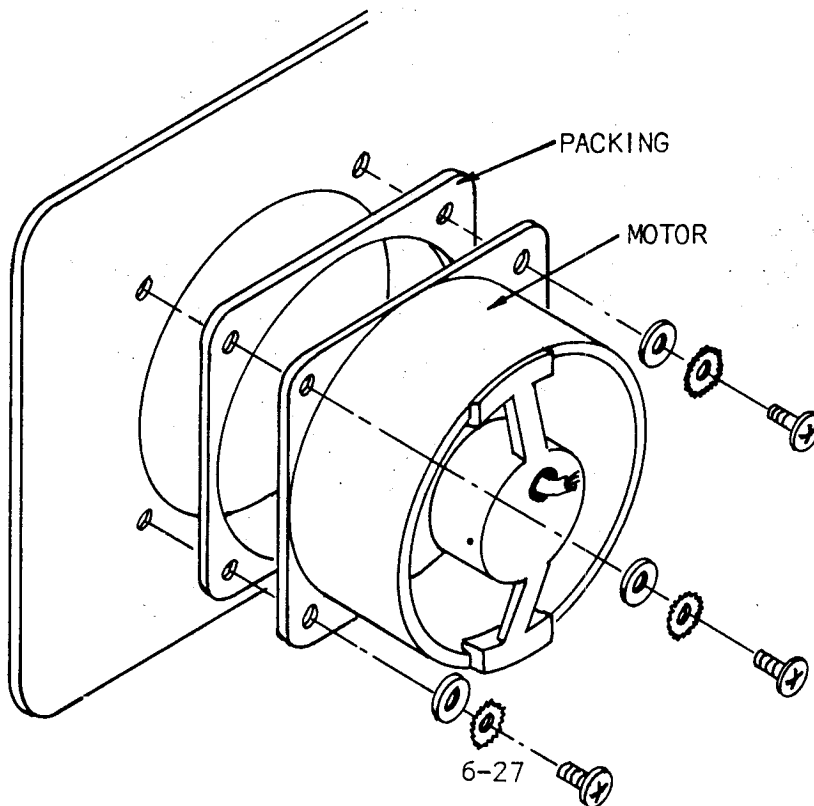

FIG. 6-31

COOLING FAN INSTALLATION  
FT-101E/EE/EX  
(100V FAN)

PARTS REQUIRED

(1) Fan Motor Assembly 2SB-10A	1 ea.
(2) 4-pin Plug	1 ea.
(3) Packing	1 ea.
(4) Washer	8 ea.
(5) Screw M3 x 10	4 ea.
(6) Vinyl Tube	20 cm.

INSTALLATION

Cut a lead from the motor to appropriate length (10 - 20 cm), insert two leads into vinyl tube. Solder these leads to the plug supplied as illustrated in Fig.6-32. Install the fan onto the rear panel of the equipment as illustrated in Fig.6-33.

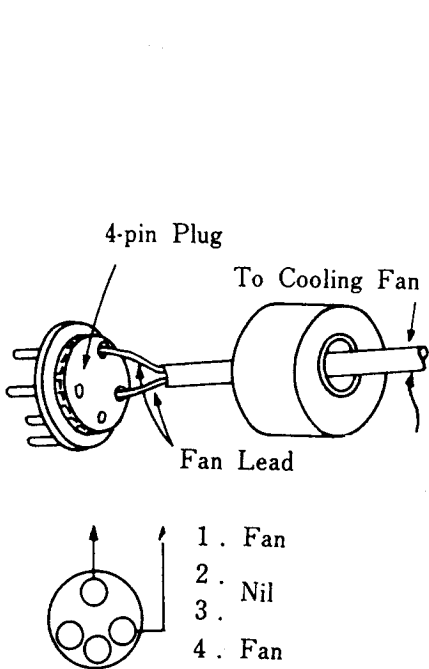

FIG. 6-32

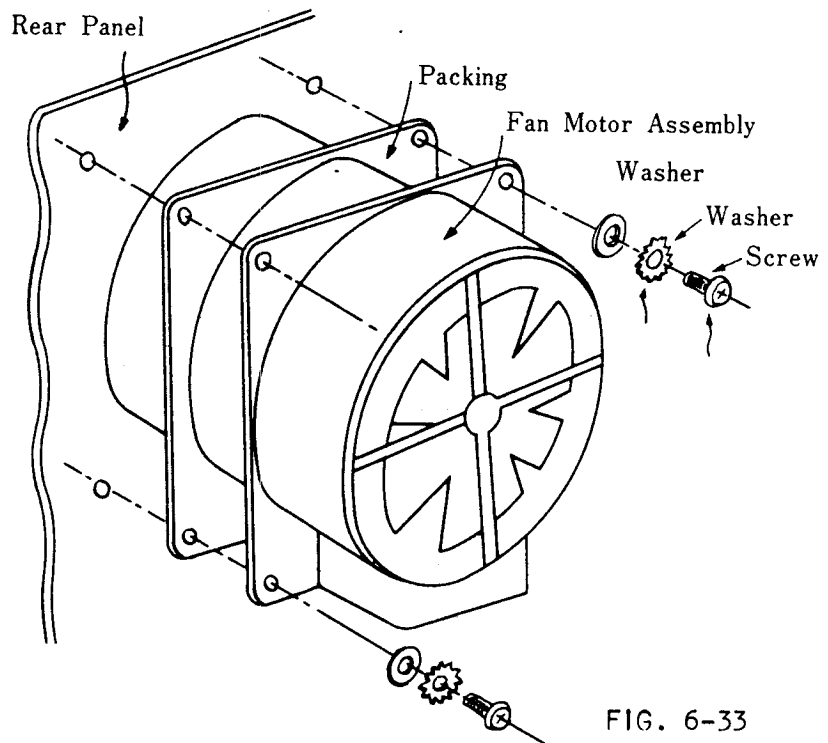

FIG. 6-33

# MODIFICATION OF FT-101B, E, EE, OR EX TO ADD FSK CAPABILITY

The circuit is set up for dry keying, and supplies 7.5 volts to a keyboard, or tape reader. (CAUTION: DO NOT APPLY VOLTAGE FROM A KEYSER, OR YOU WILL FRY THE COMPONENTS).

Shift is variable 140/850 Hz by setting the 500 ohm pot.

For Service Manuals Contact  
**MAURITRON TECHNICAL SERVICES**  
 8 Cherry Tree Rd, Chinnor  
 Oxon OX9 4QY  
 Tel:- 01844-351694 Fax:- 01844-352554  
 Email:- enquiries@mauritron.co.uk

FIG. 6-34

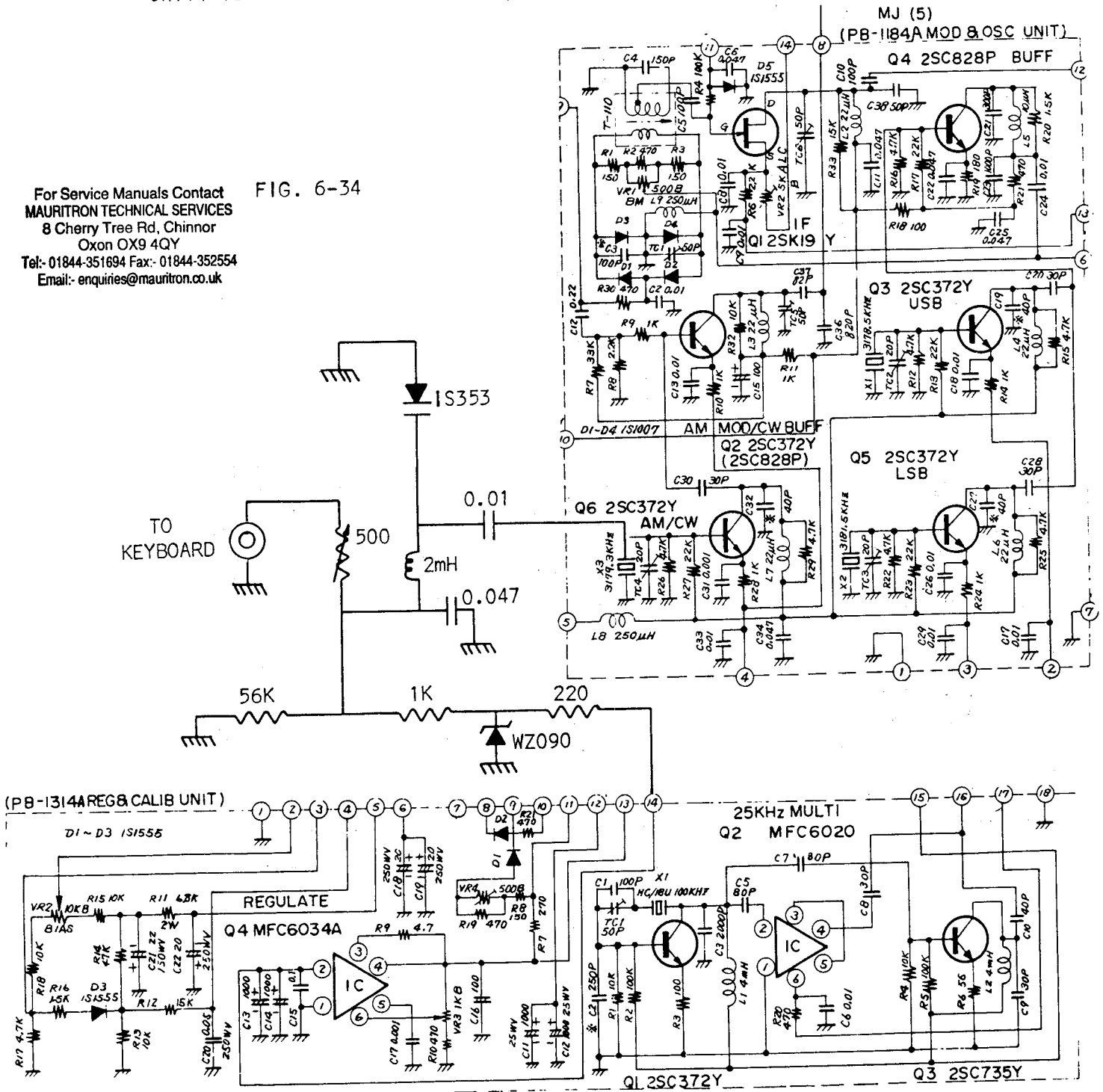

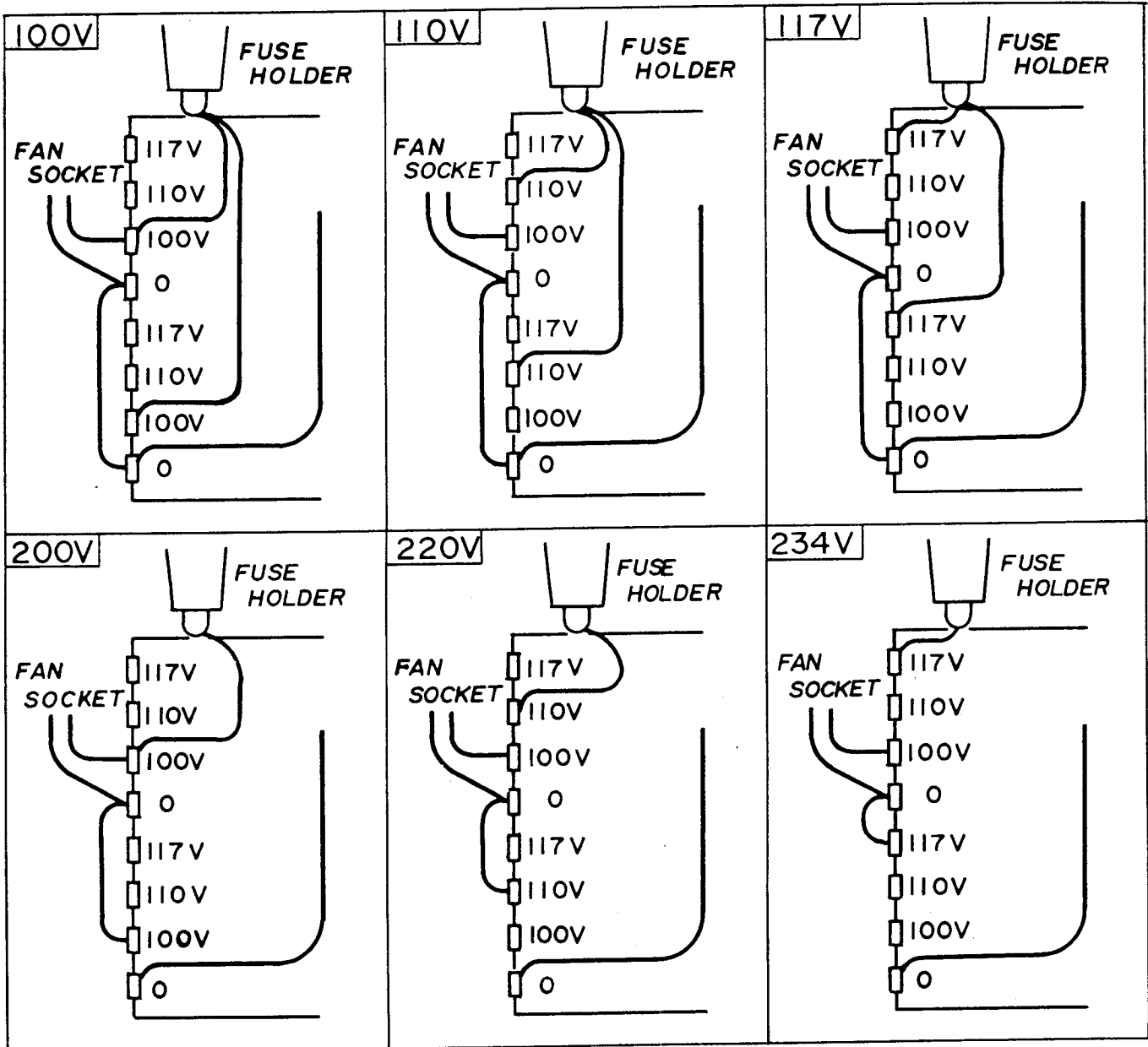

POWER TRANSFORMER CONNECTIONS

FIG. 6-35

For Service Manuals Contact  
 MAURITRON TECHNICAL SERVICES  
 8 Cherry Tree Rd, Chinnor  
 Oxon OX9 4QY  
 Tel:- 01844-351694 Fax:- 01844-352554  
 Email:- enquiries@maurtron.co.uk

MODIFICATION OF THE FT-101 SERIES  
FOR NON-STANDARD FREQUENCIES

To put the FT-101 on MARS channels requires some re-alignment and usually an hour or two of bench work, but the data provided herein should make it practical to do yourself, if you clearly understand what the FT-101 will, (and won't) do.

Since the late FT-101 series, there has been no "auxiliary" position on the band switch, so with all eleven positions of the band switch "used up", it is necessary to give up one of the bands marked on the dial.

For example, if your desired frequency is between 1.8 and 3.0 MHz, plan on using the 160 meter crystal position; between 3.0 and 5.0 MHz, the 80 meter slot; 5.0 to 8.0 MHz the 40 meter slot, and so on.

As preliminary work, identify what band you are going to use, and the crystal socket location. Look over Table 5, for frequencies between 2.0 and 3.0 MHz; Table 6 for 3.0 to 8.0 MHz and Table 7 for 8.0 to 28.0 MHz.

These tables will identify what capacitors you will need at the various oscillator, driver and final stages as you progress through the modification.

TABLE 5

Part Number	Frequency Part	2.0 MHz	2.1 MHz	2.4 MHz	2.7 MHz
		2.1 MHz	2.4 MHz	2.7 MHz	3.0 MHz
(a)	Crystal (HC-25/U)	8,020kHz	8,120kHz	8,420kHz	8,720kHz
(b)	parallel capacitance to TC26	80 pF	80 pF	80 pF	none
(c)	parallel capacitance to TC29	820 pF	820 pF	470 pF	400 pF
(d)	parallel capacitance to TC28	820 pF	820 pF	470 pF	400 pF
(e)	parallel capacitance to TC10	820 pF	820 pF	470 pF	400 pF
(f)	capacitance for S1J	ceramic 600 pF	ceramic 600 pF	ceramic 500 pF	ceramic 300 pF
(g)	capacitance for S1M	3000 pF	2500 pF	2500 pF	2000 pF
(h)	turns of PA coil	23	23	20	20



TABLE 6

BAND mHz	RECEIVE				TRANSMIT				
	XTAL FREQ	A (pF)	B (pF)	PRE SEL	FINAL COIL	PLATE	C	D	LOAD
3.0-3.5	9.02	320	470	1.6-6.5	19	5	1000	5000	5
4.0-4.5	10.02	220	250	2.0-5.4	"				
4.5-5.0	10.52	200	200	2.7-6.0	"				
6.5-7.0	12.52	150	100	3.0-5.5	"				
7.5-8.0	13.52	140	40	2.0-4.2	12	5	0	470	5

TABLE 7

BAND (mHz)	RECEIVE				TRANSMIT				
	XTAL FREQ(Z)	A (pF)	BAND	PRE SEL	FINAL COIL	PLATE	B	LOAD	VC
8.0- 8.5	14.02	130	20	0.2-1.8	12	5	0	470	5
9.5-10.0	15.52	100		3.5-4.1					
10.0-10.5	16.02			4.1-4.7					
10.5-11.0	16.52			4.7-5.2					
11.0-11.5	17.02	80		5.2-5.6					
11.5-12.0	17.52			5.6-6.0	9	5	2.5	100	1
12.0-12.5	18.02	70		6.0-6.4					
12.5-13.0	18.52			6.4-6.7					
13.0-13.5	19.02	50		6.7-7.1					
13.5-14.0	19.52			7.1-7.4					
14.5-15.0	20.52			7.8-8.1					
15.0-15.5	21.02	40		8.1-8.4					
15.5-16.0	21.52			8.4-8.7					
16.0-16.5	22.02	30	15	6.0-6.3					
16.5-17.0	22.52			6.3-6.6					
17.0-17.5	23.02			6.6-6.9					
17.5-18.0	23.52			6.9-7.1					
18.0-18.5	24.02	20		7.1-7.3					
18.5-19.0	24.52			7.3-7.5					
19.0-19.5	25.02			7.5-7.8					
19.5-20.0	25.52			7.8-8.0	5	8	2.0	0	
20.0-20.5	26.02			8.0-8.2					
20.5-21.0	26.52			8.2-8.5					
21.5-22.0	27.52			8.7-8.9					
22.0-22.5	28.02			8.9-9.1					
22.5-23.0	28.52		11	6.9-7.1					
23.0-23.5	29.02			7.1-7.3					
23.5-24.0	29.52			7.3-7.5					
24.0-24.5	30.02			7.5-7.7					
24.5-25.0	30.52	0		7.7-7.9					
25.0-25.5	31.02			7.9-8.1					
25.5-26.0	31.52			8.1-8.3					
26.0-26.5	32.02			8.3-8.4					
26.5-27.0	32.52			8.4-8.6					
27.5-28.0	33.52		10	8.7-8.9					

1. Begin the modification by tuning up the rig into a dummy load, on the band that you are going to use in the modification, to verify that no pre-existing problems are present in the rig.
2. Shut off the rig, remove the power connector and discharge the high voltage.
3. Remove the covers, including the metal plate cover over the trimmer deck.
4. Modify the local oscillator circuit by adding or removing capacity in parallel with the appropriate trimmer.
5. Insert the correct crystal, as taken from the table. (Crystal ordering data is provided in Section 1 of this manual, if you need it).
6. Now add/remove the appropriate capacitor to the mixer stage, and the driver stage, again in accord with the tables.
7. Count the turns on the final tank coil, and tap it as indicated.
8. Re-check your work, to be sure you have not hard-wired a short into the rig, and if it is up to your quality standards, re-install the boards, shields, etc., and re-align the rig.

We will step you through one of the more difficult jobs so you can see (read) what is going on, but remember that modification of an early FT-101 and a "latest issue" FT-101E is going to involve different board numbers, but by reviewing steps 1 through 8, you should be able to adjust your approach accordingly.

Let's assume you want to put an FT-101 onto 2182 kHz. First, install an 8120 kHz crystal into the 160 meter slot (or "AUX" if it is an early FT-101).

Now turn to page 7-14 and examine Fig. 7-7. It identifies the function and location of the trimmers.

1. Turn on the rig and receive the internal marker calibrator signal at 2200 kHz.
2. Check for the presence of 0.3 VDC at the oscillator test point (on PB1181) using a VTVM. Adjust TC26 as required, to get 0.3 VDC.

**For Service Manuals Contact**  
**MAURITRON TECHNICAL SERVICES**  
8 Cherry Tree Rd, Chinnor  
Oxon OX9 4QY  
Tel:- 01844-351694 Fax:- 01844-352554  
Email:- enquiries@mauritron.co.uk

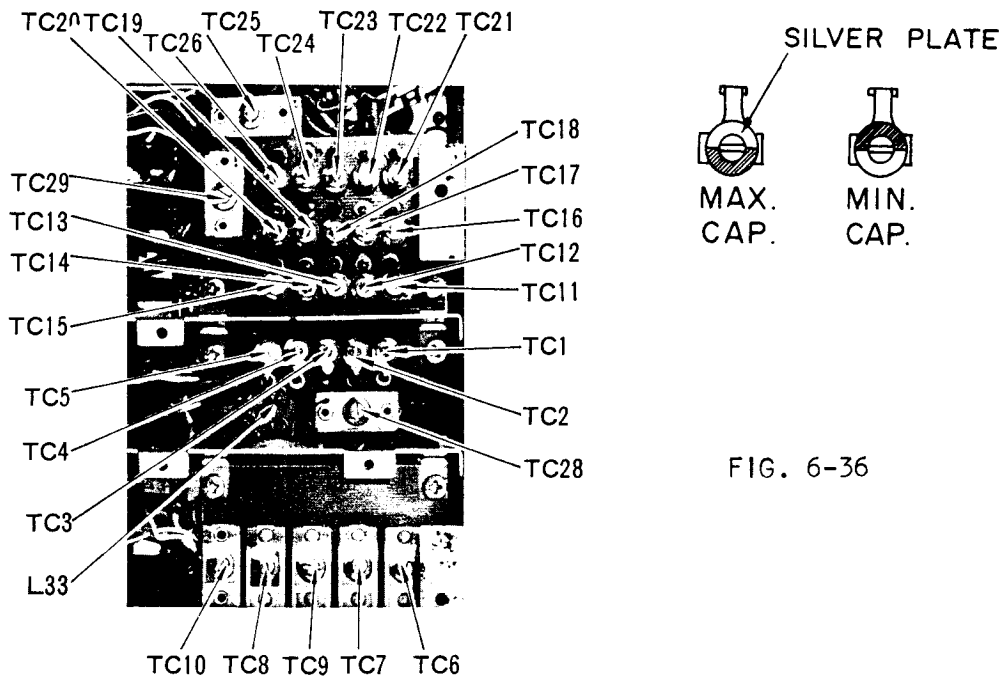

FIG. 6-36

3. Peak the calibrator signal, using the preselector set to the chart recommendation, and then peaking TC29, for maximum indication on the "S" meter. Now if you don't get a peak somewhere between minimum and maximum capacity of the trimmer, add or subtract capacity across TC29 until you do. Consider the chart value as a starting point, and select the final value only when you get a "peak", somewhere in the mid-range of the capacitor setting. (TC29 is located on PB1188A, the board closest to the front panel).
4. Now leave the preselector alone, and modify the mixer-driver by adding the recommended capacity across TC28, located on the middle board (PB1187A). Don't power up the unit yet.
5. Add the recommended capacitor to the driver plate circuit, across TC10, located on the board furthest from the front panel (PB1092). Now you can hook up the dummy load, and get ready to align the transmitter section.

## ALIGNMENT AFTER MODIFICATION

1. Connect the RF probe of VTVM to TP (test point) of T111, and adjust TC25 to give 0.3 VTVM reading.
2. Set the preselector to the position given under the preselect column. Tune the transceiver to the nearest 100 kHz marker signal of signal generator and adjust TC29 (PB1188A) and TC28 (PB1187A) for maximum "S" meter reading.
3. Tune and load the transceiver and adjust TC10 on PB1092 for maximum IC reading.  
For the frequencies given in Table 7, it is unnecessary to adjust TC10.
4. Adjust plate tune and load controls for maximum power output. The plate and load value listed in the table gives approximate setting of the controls.

When the added fixed capacity does not allow the trimmer capacitor to tune the circuit, cut and try small values of capacity until satisfactory tuning can be accomplished.

Older versions of the FT-101 (S/N 025000 and lower) had different boards, and in some cases TC29 is missing completely. If you run into this situation, don't despair, but just solder your 50pf trimmer onto the metal shaft of the band switch as shown in Fig.6-37.

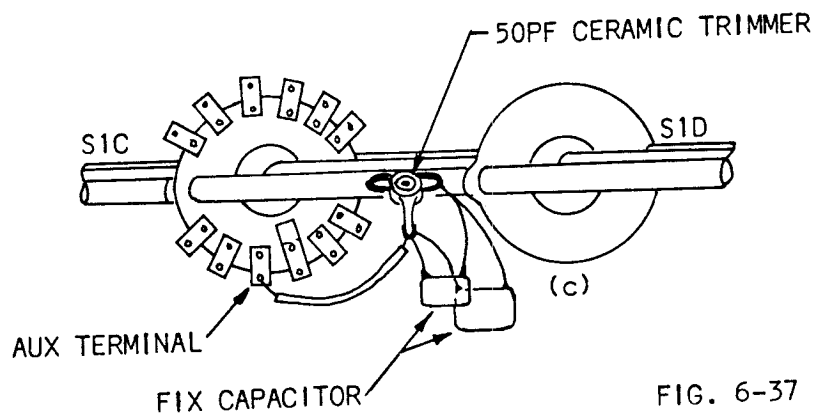

FIG. 6-37

To find S1C and S1D, look along the band switch, (which is S1) S1A is the wafer closest to the front panel, B is next, S1C is the third wafer from the front.

In these older versions, where I have referenced PB1188A, as the oscillator antenna board, it will be PB1074; PB1187A mixer board is PB1075. Otherwise, the instructions are the same, unless you use the "AUX" position on an old version. Then you will have to wire up to those open wafer terminals, as shown in the drawing.

(FOR OLDER FT-101's ONLY)

PB-1074

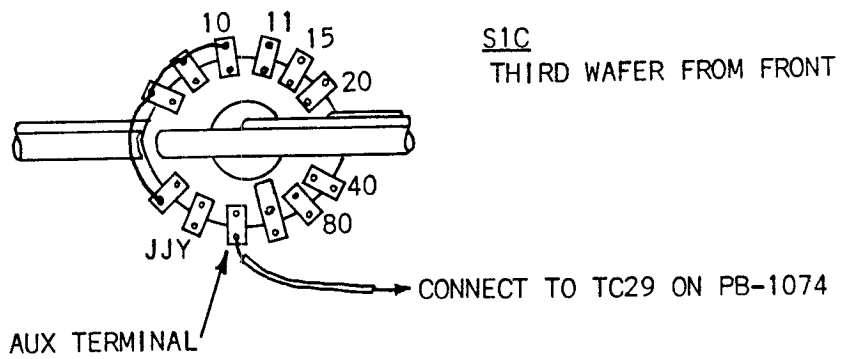
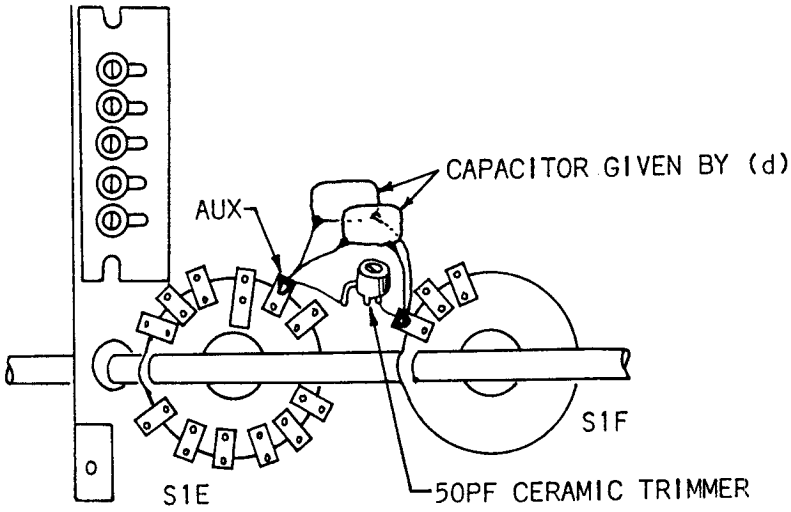
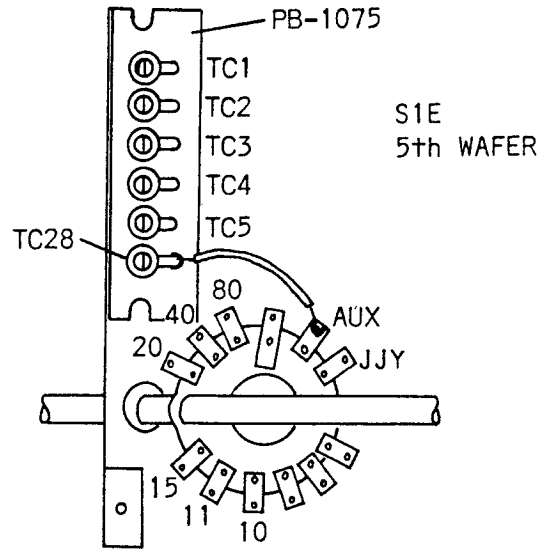
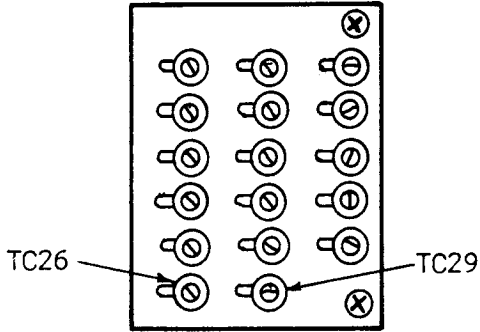

# ALIGNMENT

## SECTION 7

CONTENTS	PAGE
WARNING AND CAUTION NOTICE . . . . .	7-1
EQUIPMENT REQUIRED . . . . .	7-1
ALIGNMENT PROCEDURE, Tx AND Rx . . . . .	7-2
TRAP COIL ALIGNMENT . . . . .	7-7
HETERODYNE CRYSTAL OSCILLATOR ALIGNMENT . . . . .	7-8
"S" METER ADJUSTMENT . . . . .	7-9
NOISE BLANKER ADJUSTMENT . . . . .	7-9
SIDETONE LEVEL ADJUSTMENT . . . . .	7-9
VOX ADJUSTMENT . . . . .	7-9
CARRIER BALANCE NULLING . . . . .	7-10
ALC LEVEL ADJUSTMENT . . . . .	7-10
RF PROCESSOR . . . . .	7-10
BIAS ADJUSTMENT . . . . .	7-11
FINAL AMPLIFIER NEUTRALIZATION . . . . .	7-11
POWER OUTPUT (PO) ADJUSTMENT . . . . .	7-12
BAND PASS FILTER ADJUSTMENT . . . . .	7-17

For Service Manuals Contact  
**MAURITRON TECHNICAL SERVICES**  
8 Cherry Tree Rd, Chinnor  
Oxon OX9 4QY  
Tel: 01844-351694 Fax: 01844-352554  
Email: enquiries@mauritron.co.uk

## GENERAL

### WARNING

DANGEROUS VOLTAGES ARE PRESENT. USE EXTREME CAUTION WHEN WORKING ON THE TRANSCEIVER WITH COVERS REMOVED, AND THE POWER IS ON. DISCHARGE ALL CAPACITORS BY SHORTING TO GROUND AFTER REMOVING THE POWER, TO AVOID BEING SHOCKED BY A FULLY CHARGED CAPACITOR, WHEN YOU LEAST EXPECT DANGER.

The transceiver was carefully aligned and tested at the factory, however, service or replacement of a major component may require subsequent realignment. Don't begin a realignment however, unless the operation of the transceiver is fully understood, the malfunction has been analyzed and definitely traced to misalignment.

Service work should be performed by experienced personnel, using the proper test equipment, however, careful reading of this manual will usually result in a successful job.

Capacitors, resistors, inductors, and transformer adjustments should not be varied more than a few degrees in either direction from their original setting. If the adjustments require varying by an appreciable amount, check for the presence of a defect other than alignment.

### CAUTION

NEVER OPERATE THE TRANSCEIVER IN THE TRANSMIT MODE WITHOUT A MATCHED ANTENNA OR ADEQUATE DUMMY LOAD. THE POWER AMPLIFIER TUBES AND PI NETWORK COMPONENTS CAN BE DAMAGED IF THE TRANSCEIVER IS OPERATED WITHOUT THE PROPER LOAD TERMINATION.

#### EQUIPMENT REQUIRED:

1. RF Signal Generator: Hewlett-Packard Model 606A, or equivalent with one volt output at an impedance of 50 ohms and a frequency coverage to 30 MHz.
2. Vacuum Tube Voltmeter (VTVM): Hewlett-Packard Model 410B, or equivalent VTVM with an RF probe good to 40 MHz.
3. Dummy Load: Yaesu YP-150 or equivalent 50 ohms non-reactive load rated at 150 watts CW power.
4. AF Signal Generator: Hewlett-Packard Model 200 AB or equivalent.
5. A General Coverage Receiver covering the frequency range from 3 to 30 MHz with a 100 kHz calibrator. FRG-7, FR-101 or equivalent.
6. Frequency Counter, Yaesu YC-355D or equivalent.

## ALIGNMENT OF TRANSMITTER MIXER/DRIVER AND RECEIVER FRONT END STAGES

The final amplifier bias adjustment must be set to 60 ma before extensive operation of the transmitter is attempted. It is assumed that the signal generating stages of the transceiver are functioning properly. You can use the internally generated signal of the transceiver to align the transmitter mixer and driver stages, and the RF signal generator to align the receiver front end stage.

We will start at the highest frequency of the rig, and align the transmitter section, then without moving the preselector, align the receiver so it peaks at the same point. If you get a rig where Tx and Rx do not peak at the same point, chances are good that re-alignment in accordance with this procedure will cure your difficulty.

Then, we will align the various traps, and set the adjustments. If you work carefully, your FT-101 will emerge from the alignment meeting all factory specifications.

Remove the covers, and read through the procedure, so you understand the system we will be using, and where the alignment points are located.

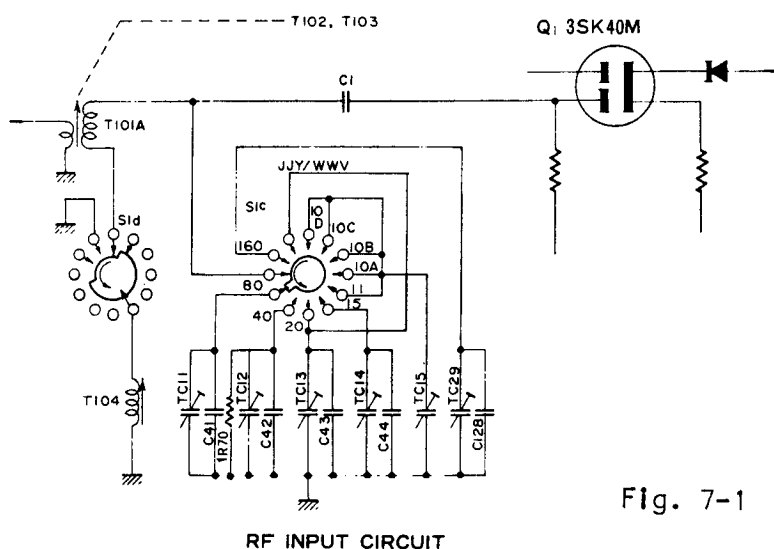

Fig. 7-1

BAND	COIL	CAPACITOR	TRIMMER
160		C128 820 PF	TC29
80	T101A+T104	C41 240	TC11
40		C42 30P	TC12
20		C43 50 PF	TC13
15	T101A	C44 20 PF	TC14
10			TC15

NOTE: See Fig.1-4 in Section 1 for the test setup we use.

1. Connect a 50 ohm non-reactive dummy load to the antenna jack. Tune up the transceiver at 30,000 kHz (BAND 10D, VFO at 30,000 kHz) as follows:
  - a. Set the BAND switch to 10D, the VFO to 30,000 kHz, PRESELECTOR control to the upper end of 10 and 11 meter segment and the OPERATION switch at MOX. Don't leave it in the MOX position for more than 10 seconds at a time until it is in resonance!



- b. Advance the CARRIER control and tune the final amplifier.
  - c. Don't exceed a resonant plate current (IC) of 100 ma. Use the CARRIER control to adjust it up or down as required.
  - d. Locate and set trimmer TC5 (Fig. 7-2 , bottom) to the mid-capacitance position (Fig. 7-2). Soften the glue holding the spring shafts, and adjust the slugs of T102 and T103 (part of the PRE-SELECTOR gang on top of the chassis) for maximum output into the dummy load.
  - e. After you have peaked T102 and T103, reduce the transmitter output to zero with the CARRIER control, and switch off the MOX.
2. Set the OPERATION switch to PTT, RF and AF GAIN control to maximum, CLARIFIER control to "OFF", and NOISE BLANKER to "OFF". Do not change the VFO setting and PRESELECTOR control setting set up in step 1. Tune the RF signal generator to 30,000 kHz and adjust it for approximately 1,000 Hz beat note. Use just enough signal generator output (approximately 1 microvolt for an aligned unit) to keep from developing AGC voltage (no S-meter indication). Set trimmer TC15 to the mid-capacitance position. Adjust the slug of T101 for maximum audio output without developing AGC voltage. Reduce the signal generator output as required, to prevent developing AGC.

the signal generator and re-connect the dummy load.

3. Set the BAND switch at 10A, the VFO at 28,000-kHz and the "MOX-PTT-VOX" switch at MOX. Advance the CARRIER control and tune the final amplifier. Maintain the plate current at 100 ma with the CARRIER control as described before.

Now set the PRESELECTOR control to the lower end of the 10 and 11 meter segment marked in the panel, and re-adjust trimmer TC5 for maximum output at the dummy load. After you have set it at the peak, reduce the transmitter output to zero with the CARRIER control, and switch back to PTT.

4. Without changing the VFO or PRESELECTOR control settings, tune the RF signal generator to 28,000 kHz and obtain a 1,000 Hz beat note.
- Control the signal generator output as before, to avoid AGC action and adjust trimmer TC15 for maximum audio output as described in step 2.
5. Repeat steps 1,2,3 and 4 to peak out the coil adjustments for the 10 meter band.

6. So now you have the 10 meter (and that includes 11 meter) band aligned. Set the BAND switch to 15, the VFO to 21,000 kHz and the PRESELECTOR to the lower edge of the 15 meter segment. Tune up the transceiver to 21,000 kHz as described above. Adjust trimmers TC4 and TC9 for maximum transmitter output into the dummy load.
7. After you have peaked TC4 and TC9, set the OPERATION switch to PTT, and without changing the VFO or PRESELECTOR settings, tune the RF signal generator to 21,000 kHz and obtain the 1,000 Hz beat note. Adjust trimmer TC14 for maximum audio output as described in step 2.
8. Repeat the procedures given in steps 6 and 7 on the 20 meter band. Trimmers TC3 and TC8 are used for maximum transmitter output and TC13 for maximum audio output in receive.

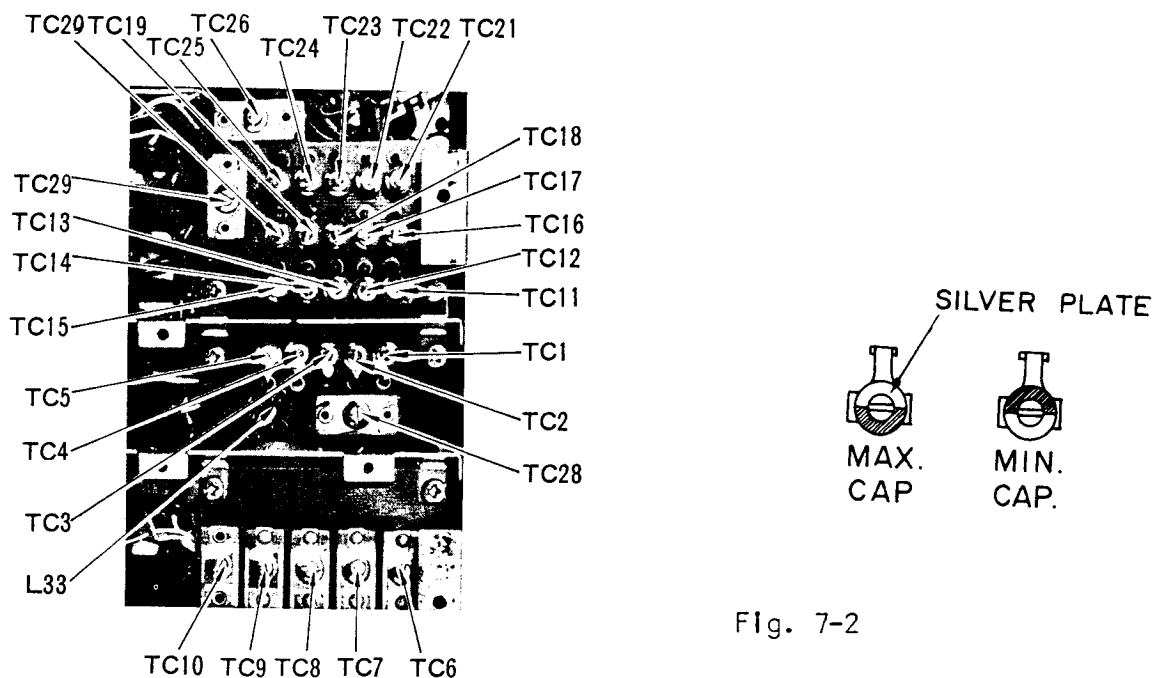
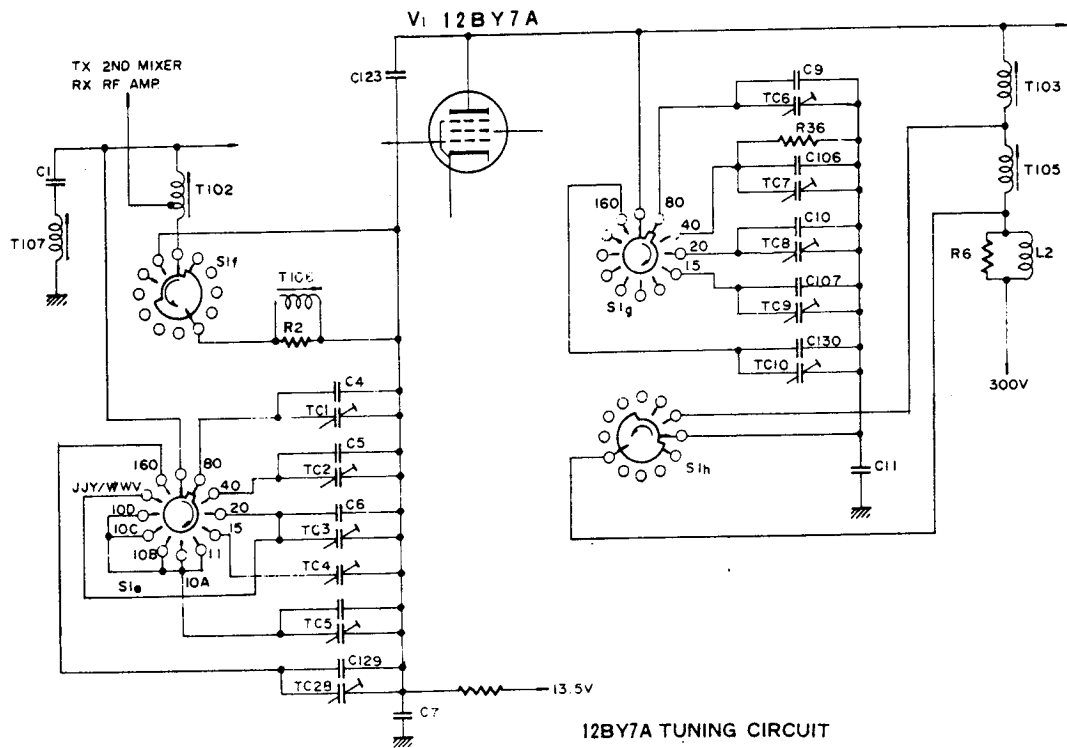

Fig. 7-2

9. Set the BAND switch at 80, VFO at 4,000 kHz, and the PRESELECTOR at 7 of the inner scale. Pre-set TC1 and TC6 at their mid-capacitance point. Then tune the transceiver to 4,000 kHz and adjust T105 and T106 for maximum transmitter power output into the dummy load.
10. Set the OPERATION switch to PTT, and without changing the VFO or PRESELECTOR settings, tune the RF signal generator to 4,000 kHz and obtain a 1,000 Hz beat note. Pre-set TC11 to the mid-capacitance point. Adjust T104 for maximum audio output as described in step 2. T104 takes a nylon hex alignment tool, and is held in position with wax. See Fig.7-6 for it's location, and don't forget to soften the wax before trying to turn it. We see many cracked cores from absent-minded servicemen!

11. Set the PRESELECTOR to the lower edge of the 80 meter segment, VFO at 3,500 kHz, and adjust TC1 and TC6 for maximum transmitter power output into the dummy load.
12. Set the OPERATION switch to PTT, and without changing the VFO or PRESELECTOR settings, tune the RF signal generator to 3,500 kHz and obtain a 1,000 Hz beat note. Then adjust TC11 for maximum audio output as described in step 2.
13. Repeat steps 9, 10, 11, and 12 to peak out the coil adjustments for optimum on the 80 meter band.
14. Set the BAND switch to 40, VFO at 7,000 kHz and the PRESELECTOR to the lower edge of the 40 meter segment. Adjust TC2 and TC7 for maximum transmitter power output into the dummy load. (Note your settings, because you will have to come back to them in step 16).
15. Set the VFO at 7,150 kHz and PRESELECTOR for maximum power output. Adjust L33 for maximum power output into the dummy load.
16. Set the OPERATION switch to PTT, and set the VFO and PRESELECTOR settings to the same position as step 14, tune the RF signal generator to 7,000 kHz and obtain a 1,000 Hz beat note. Adjust TC12 for maximum audio output.
17. Set the BAND switch to 160, VFO at 1,900 kHz and the PRESELECTOR at 2 of the inner scale. Adjust TC28 and TC10 for maximum power output into the dummy load.
18. Turn the OPERATION switch to PTT, and leave the VFO and PRESELECTOR settings unchanged. Apply the RF signal generator output at 1,900 kHz to antenna terminal. Adjust TC29 for maximum S-meter reading.

For Service Manuals Contact  
MAURITRON TECHNICAL SERVICES  
8 Cherry Tree Rd, Chinnor  
Oxon OX9 4QY  
Tel:- 01844-351694 Fax:- 01844-352554  
Email:- enquiries@mauritron.co.uk



BAND	GRID CIRCUIT			PLATE CIRCUIT		
	COIL	CAPACITOR	TRIMMER	COIL	CAPACITOR	TRIMMER
160	T102+T106	C129 820P	TC28	T103+T105	C130 820P	TC10
80		C4 200P	TC1		C9 200P	TC6
40		C5 30P	TC2		C106 30PF	TC7
20	T102	C6 50PF	TC3	T103	C10 50PF	TC8
15			TC4		C107 10PF	TC9
10			TC5			

Fig. 7-3

## TRAP COIL ALIGNMENT

1. T107 is used to eliminate the direct feed through interference at the IF frequency, and is tuned to 5,720 kHz. Set the transceiver at 7,300 kHz LSB in receive mode and peak the PRESELECTOR for maximum noise output. Set the RF signal generator to 5,720 kHz and increase the signal generator output until an audio beat note is heard. Adjust T107 for minimum audio output.
2. L29 is located on the printed circuit board near the antenna changeover relay RL2. It is also used to eliminate direct feed through interference. Set the transceiver at 7,080 kHz in the receive mode. Tune the RF signal generator to 5,940 kHz. Adjust L29 for minimum S-meter reading.
3. L22 eliminates the interference by the 9th harmonic of the carrier oscillator. Tune the transceiver to 28,600 kHz USB in the receive mode, and increase RF and AF gain control until an audio beat note is heard. Adjust L22 for minimum audio output.
4. T113 in the high frequency IF unit (PB1180B) is used to minimize spurious radiation on the 20 meter band. For alignment, tune transceiver to maximum output into a dummy load at 14,350 kHz in the tune position. Measure the spurious radiation, by using the S-meter of another receiver tuned to 14,520 kHz where a spurious radiation can be heard. Adjust T113 for minimum S-meter reading on the external receiver without decreasing the power output of the transceiver.
5. T115 is located on a printed circuit board near the VFO unit and is used to suppress carrier oscillator feed through. Tune the transceiver to any frequency and load it to full output. Reduce the microphone gain to zero and place the mode switch in the USB position. Adjust T115 for minimum S-meter reading on an external receiver, tuned to the frequency you set the transceiver up on.
6. L28 is used to eliminate spurious radiation on the 15 meter band. Tune the transceiver to maximum output at 21,200 kHz in the tune position. Locate the spurious radiation at 21,220 kHz on another receiver, then adjust L28 for minimum S-meter reading on the external receiver.
7. TC30 is connected in series with L32 on a printed circuit board located on the main chassis near the relay RL1. It is used to eliminate spurious radiation on the 10 meter band. For alignment, tune the transceiver to maximum output at 28,500 kHz in the tune position. Measure the level of spurious radiation by using the S-meter of another receiver tuned to 28,160 kHz where the spurious signal can be heard. Adjust TC30 for minimum S-meter reading on the external receiver without decreasing the power output of the transceiver.

## HETERODYNE CRYSTAL OSCILLATOR ALIGNMENT

The heterodyne crystal oscillation injection may be checked in the following manner. Connect the VTVM RF probe to the local oscillator test point. Injection is normal if the injection voltage measures 0.3 volt RMS on all bands.

If not, alignment is required. Set the BAND switch at 10D, TC24 at 1/3 capacitance position, and adjust T111 for 0.3 volt RMS reading on VTVM. Then adjust TC23, TC22, TC21, TC16 and TC26 for each of the band to read 0.3 volt RMS on VTVM.

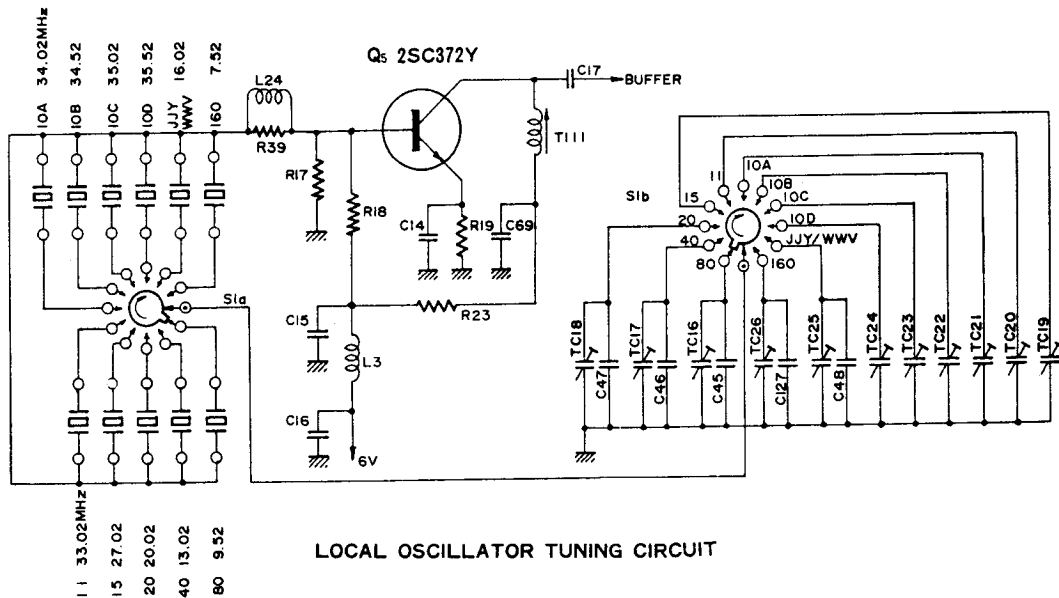

Fig. 7-4

BAND	Na	TUNING CAPACITOR		CRYSTAL FREQUENCY
		Value	Type	
160	X11	C127 250PF	TC26	7.52MHz
80	X 1	C45 300PF	TC16	9.52MHz
40	X 2	C46 150PF	TC17	13.02MHz
20	X 3	C47 50PF	TC18	20.02MHz
15	X 4		TC19	27.02MHz
11	X 5		TC20	33.02MHz
10A	X 6		TC21	34.02MHz
10B	X 7		TC22	34.52MHz
10C	X 8		TC23	35.02MHz
10D	X 9		TC24	35.52MHz
WWV	X10	C48 100PF	TC25	16.02MHz

## S-METER ADJUSTMENT

Use a signal generator with a calibrated attenuator, (such as the HP-606A) matched to a 50 ohm unbalanced load.

Connect the signal generator to the antenna terminal and set it to 14,200 kHz, with an output of 50 microvolts. Tune the transceiver for the maximum S-meter reading. Adjust VR2 on PB1183B so the meter reads 25 over S-9. Disconnect signal generator.

## NOISE BLANKER THRESHOLD ADJUSTMENT (PB1292 BLANKER)

The operating threshold of the noise blanker is set by VR1 on the PB1292 board. (It is marked "NB" on most units) Counter clockwise rotation of the control increases the effectiveness, but an extreme setting will affect the sensitivity of the receiver, so use judgement.

Switch on the calibrator and tune it in at 14,100 kHz, peaking for maximum S-meter indication with the noise blanker off. Switch the noise blanker on, and if the blanker is set properly, the meter will decrease 1/2 to 1 "S" unit. Adjust VR1 to get the proper setting.

## VOX ADJUSTMENT

VOX controls are located on PB1315A. These are VR1 VOX Gain, VR2 Delay, VR3 Relay Sensitivity and VR5 Antitrip Gain.

Set the operation switch to the VOX position and turn the AF GAIN and MIC GAIN controls fully counter clockwise. Slowly rotate the RELAY control (VR3) clockwise until the relay activates, then return the control carefully counter clockwise until relay releases. This release point is the proper setting for the RELAY sensitivity control.

Set MIC GAIN control to the center of it's travel. Speak into the microphone normally, adjust VOX control VR1 to just activate VOX relay.

Tune in a signal and adjust the AF GAIN control to a comfortable listening level. Set the ANTITRIP control VR5 to the minimum point that will prevent the speaker output from tripping the VOX.

Adjust the DELAY control VR2 for suitable release time.

## CW SIDETONE LEVEL ADJUSTMENT

CW sidetone level may be adjusted by rotating the TONE level potentiometer (VR4) located on PB1315A.

## CARRIER BALANCE

The transceiver should be allowed to reach operating temperature before making carrier balance adjustments.

Tune up the transceiver for SSB operation using a dummy load. Turn the MIC GAIN control fully counter clockwise to remove all audio from the modulator stage.

With the MODE switch set to either the LSB/USB positions, turn the "MOX-PTT-VOX" switch to the MOX position and adjust the carrier balance controls (VR1 and TC1) on PB1184A for minimum P0 meter reading.

A more precise balance may be obtained by tuning a receiver, having an S-meter, to the transmitted frequency. Adjust the balance controls for minimum S-meter reading while switching the MODE switch back and forth between the two sideband positions to obtain best carrier suppression for both sidebands, as indicated on the external receiver.

## ALC LEVEL ADJUSTMENT

To adjust the meter, set the controls as follows:

MODE . . . . .	USB
MIC GAIN . . . . .	FULLY CCW
MOX-PTT-VOX . . . . .	MOX

If the meter reads other than .5 on the bottom scale, adjust the ALC control VR2 on PB1184A for a meter indication of .5. Return the "MOX-PTT-VOX" switch to the PTT position. On the FT-101E, VR2 is found on the processor board. Otherwise adjustments are the same.

## RF PROCESSOR

Set the MODE switch to SSB (either USB or LSB) position, and the HEATER switch to OFF position. Connect the 1 kHz audio signal generator output to the MIC input terminal. Set the MIC control to 12 o'clock position and the FUNCTION switch to MOX position. Adjust the audio signal level to give 50mv input to the RF processor unit.

Set the PROCESS switch on the front panel to OFF position. Adjust VR2 on the RF processor printed board for 50 mv output level at the processor output.

Set the PROCESS switch to ON position and VR1 to fully counter clockwise position. Peak T<sub>1</sub> for maximum output at the processor output. Set the VR1 to the point where the RF processor output level becomes equal to the input level (unity gain).

Finally increase the audio input from the microphone until the RF processor input becomes 100 mv. Under this condition, the processor output level is approximately 60 mv when the RF processor is properly adjusted.



## VOLTAGE REGULATOR ADJUSTMENT

Connect a VTVM DC probe between pin 13 of MJ6 (PB1314A) and ground. Adjust volt potentiometer VR3 for exactly 6 volt reading on VTVM.

## CLARIFIER ADJUSTMENT

The frequencies should coincide at CLARIFIER control OFF and 0 positions in the receive mode. If not, adjust potentiometer VR4 located near the clarifier control potentiometer under the main chassis until they do. (See Fig.7-6).

Transmitter and receiver frequencies should coincide at the CLARIFIER control OFF position. If not, adjust the ZERO potentiometer VR4 on PB1314A. (This is VR3 on PB1547 - see pages 5-22 and 5-33).

## BIAS ADJUSTMENT

The final amplifier bias must be checked to insure linearity and normal operating plate dissipation for the final tubes. Adjust the BIAS control VR2 on PB1314A as follows: Set the transceiver to the receive mode and allow the transceiver to reach operating temperature.

Connect the transceiver to a dummy load. Set the MODE switch to USB, METER switch to IC and the "MOX-PTT-VOX" switch to MOX position for transmit condition. The meter will indicate PA plate current. Idle plate current is 60 ma if the bias is correct. If not, adjust VR2. (This is VR1 on PB1547).

## FINAL AMPLIFIER NEUTRALIZATION

When replacing the final amplifier tubes, it may be necessary to reset the bias to give correct idle current and check neutralization. Using the procedure outline below will guarantee maximum output and long tube life.

### CAUTION

HIGH VOLTAGES ARE PRESENT ON UNDERSIDE OF CHASSIS  
AND INSIDE OF FINAL COMPARTMENT. USE GREAT CARE  
WHILE MAKING ADJUSTMENTS WITH WIRING EXPOSED.

1. Connect a dummy load to antenna, and set meter to IC.
2. Locate TC27 the neutralization variable capacitor shaft on the underside of the chassis near the driver stage band switch wafer, in the final amplifier section.
3. Check final amplifier idle current in USB or LSB position and adjust as described before.
4. Tune up the transceiver at 29 mHz, 10B or 10C band with MODE switch at TUNE position, and advance the CARRIER control until meter IC reads 200 ma.

5. Rotate PLATE tuning control and observe dip as indicated on the meter. If the dip is not prominent, reduce the loading control slightly for better indication. As the PLATE control is rotated the meter should rise equally and smoothly on either side of maximum dip indication.
6. Determine which side of the dip rises abruptly. Set PLATE control slightly to this side of dip keeping the meter reading below 100 ma.
7. Using nonmetallic tuning wand, rotate neutralization capacitor shaft very slightly in the direction which reduces the current shown on the meter. Repeat steps 6 and 7 until the meter indicates a smooth and equal rise on either side of the maximum dip point.

The final compartment cover must be in place to supply the RF shielding required during the neutralization procedure.

#### POWER OUTPUT METER ADJUSTMENT

VR6, located on the transceiver rear panel adjacent to the antenna coax fitting, provides an adjustment for power output indication on the meter.

This potentiometer should be adjusted to indicate 1/2 to 2/3 full scale meter deflection when the transmitter is producing full output power in the tune position.

It should be noted that the meter indicates relative power output and is not the basis for determining actual power output.

VR6 has been preset at the factory to read 1/2 to 2/3 full scale into a 52 ohm dummy load. The operator should not indiscriminately adjust VR6 into an unknown load or an antenna with high VSWR.

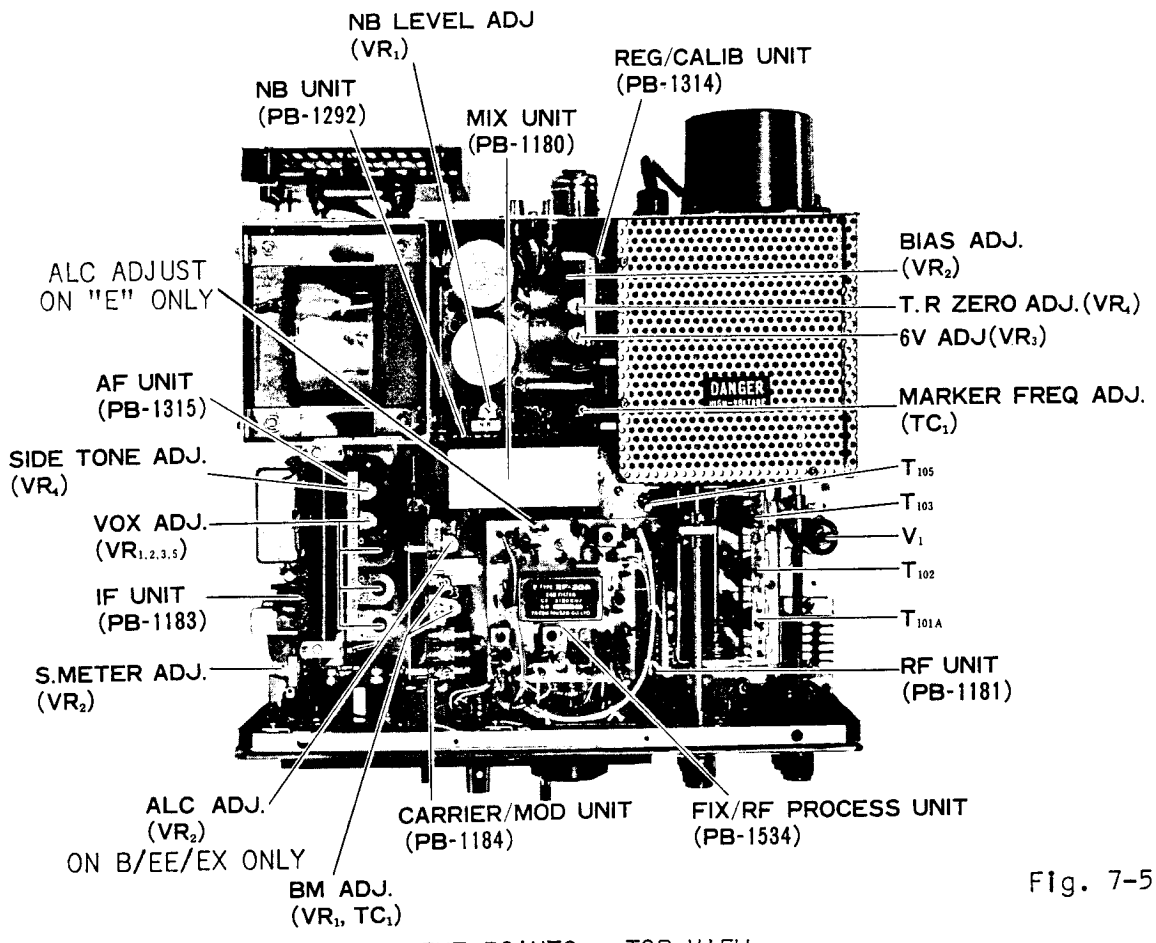

Fig. 7-5

ALIGNMENT POINTS - TOP VIEW

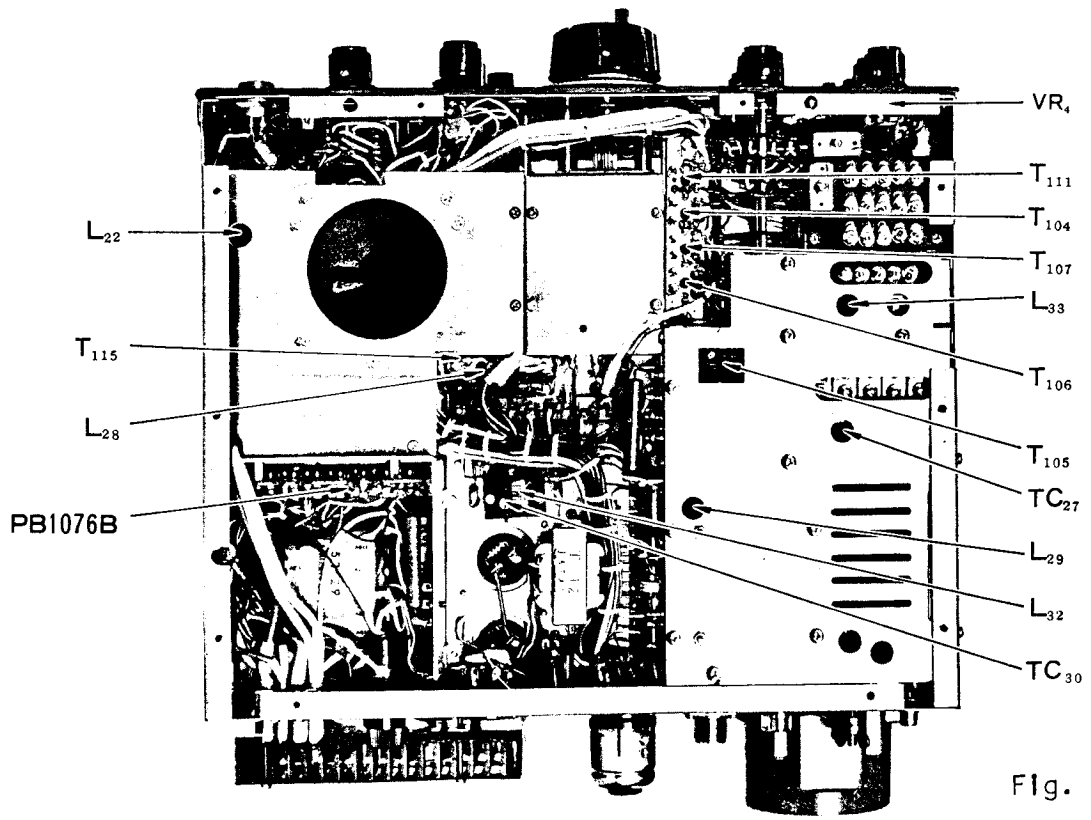

Fig. 7-6

ALIGNMENT POINTS - BOTTOM VIEW

For Service Manuals Contact  
**MAURITRON TECHNICAL SERVICES**  
 8 Cherry Tree Rd, Chinnor  
 Oxon OX9 4QY  
 Tel:- 01844-351694 Fax:- 01844-352554  
 Email:- enquiries@mauritron.co.uk

# TRIMMER DECK

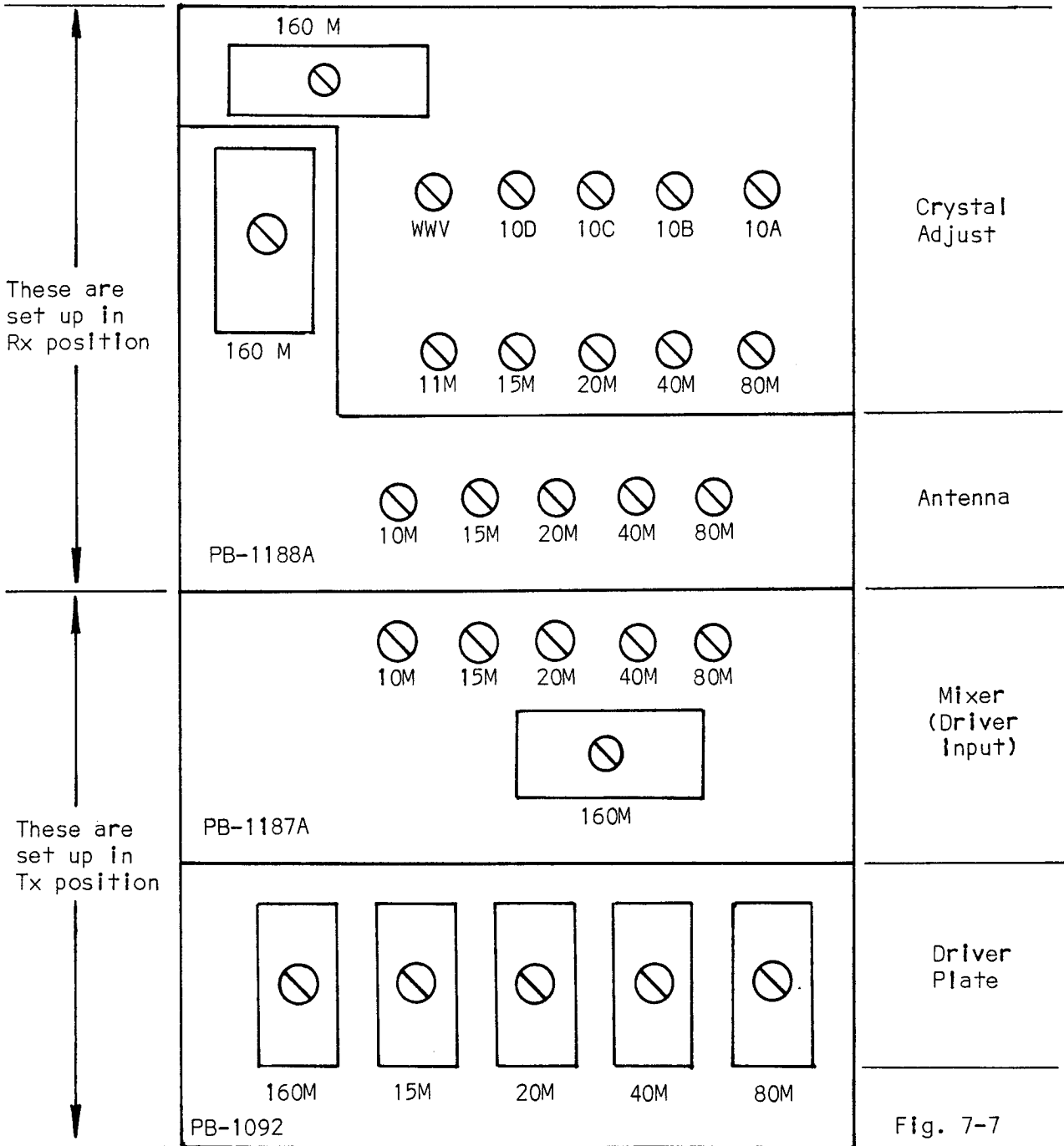
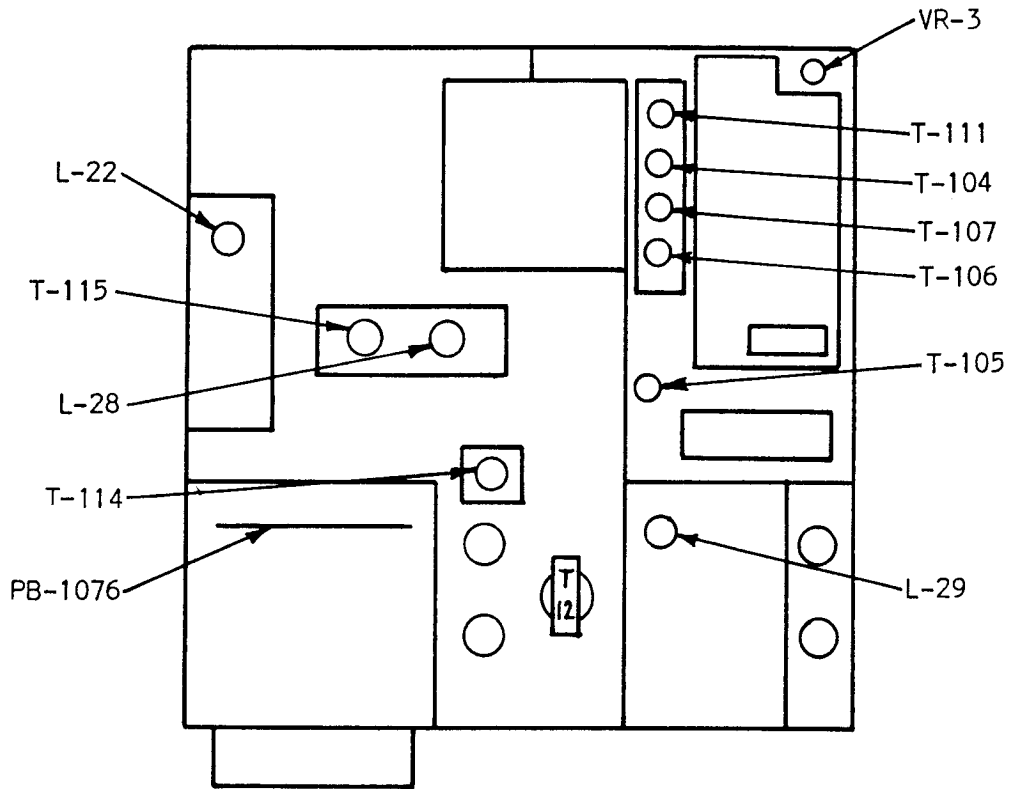

Fig. 7-7

# ALIGNMENT POINTS

(BOTTOM VIEWS)



FT-101

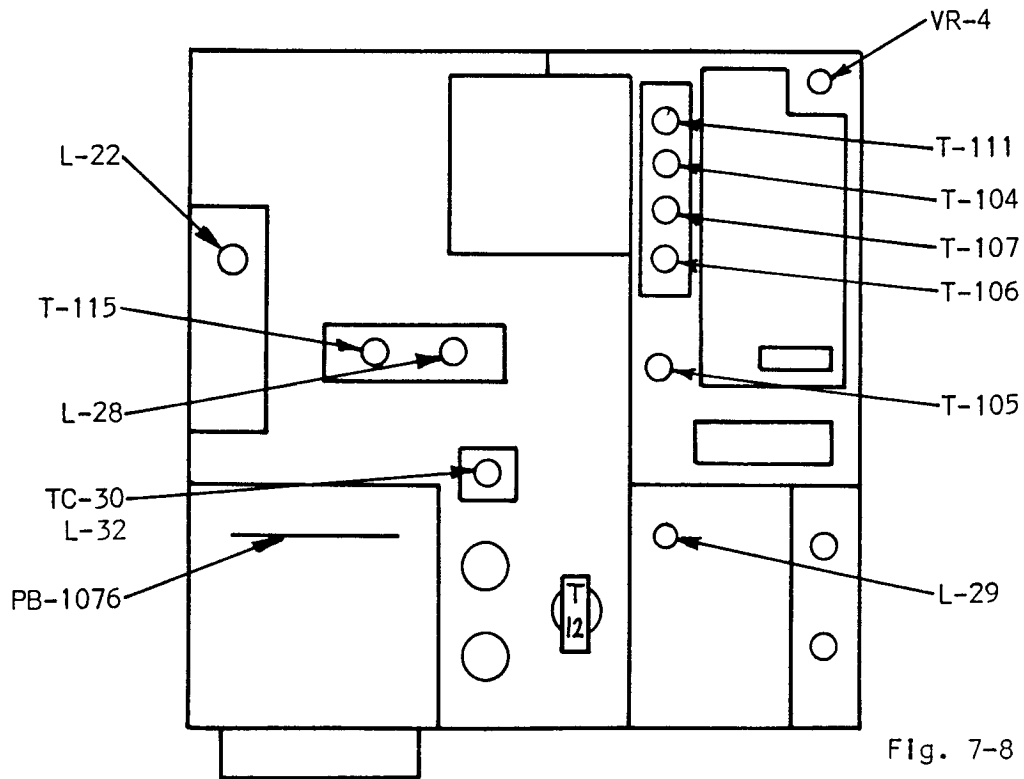

Fig. 7-8

FT-101-B

7-15

For Service Manuals Contact  
MAURITRON TECHNICAL SERVICES  
8 Cherry Tree Rd, Chinnor  
Oxon OX9 4QY  
Tel: 01844-351694 Fax: 01844-352554  
Email: enquiries@mauritron.co.uk

# ALIGNMENT POINTS

(BOTTOM VIEW)

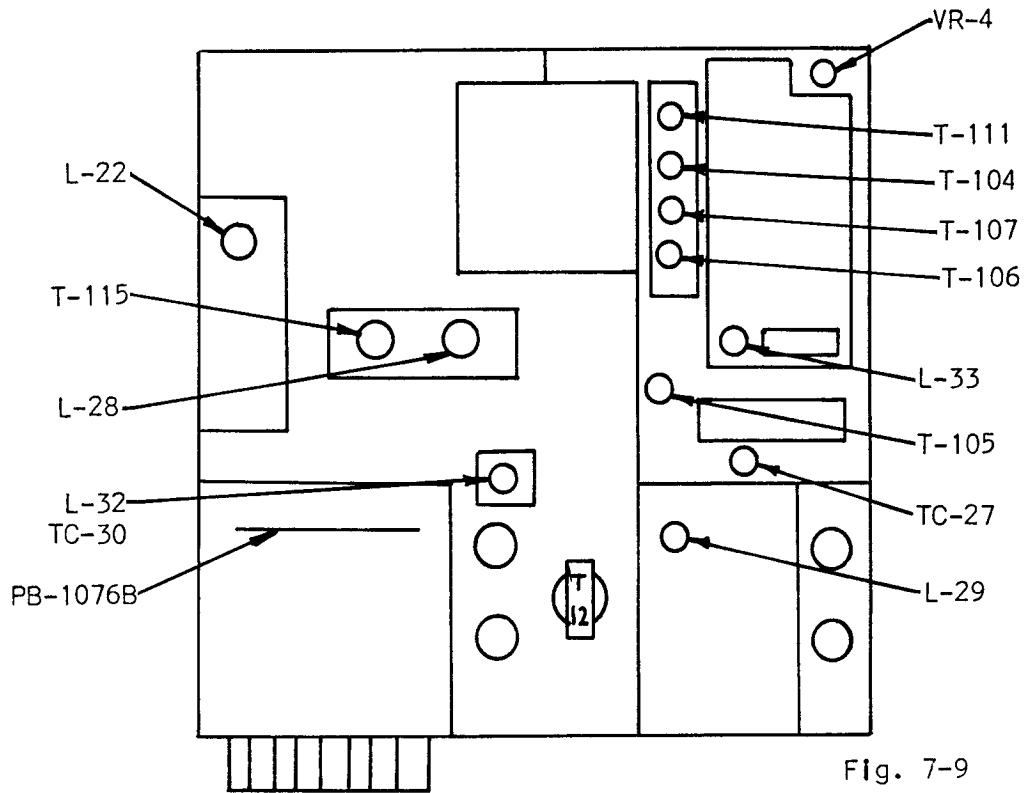

Fig. 7-9

FT-101 E/EE/EX

## BAND PASS FILTER ADJUSTMENT

The band pass filter located in PB1180 serves to minimize spurious frequencies that normally occur in a mixer, and also to provide improved impedance matching across the desired 5.52 - 6.02 MHz band.

A typical complaint that would cause a repairman to check out this circuit, would be a report of unequal power output from the low end of the VFO to the high end of the VFO, and most pronounced on the 10 m bands where the entire VFO spread is used.

To check it, set up the FT-101 on band 10B (28.5 - 29.0) using a dummy load such as the YP-150.

Use a microphone with the rig in the PTT position, to key it on and off, as you go through the following tests, to avoid damaging the finals. Just key it on long enough to read the meter, or make your adjustments.

Tune the rig up at 28.75 MHz, for maximum power in the tune position, then using the carrier control, reduce the plate current indicated on the "S" meter, (IC position) to 200 ma. (Don't overheat the tubes while tuning up).

Now go through the following steps:

1. Tune up at 28.5 MHz (bottom of VFO) leaving the carrier level alone. The meter should read 200 ma  $\pm$ 5 ma.
2. Tune up at 28.75 MHz (middle of VFO) the meter should read 200 ma  $\pm$ 10 ma.
3. Tune up at 29.0 MHz (top of VFO) meter should read 200 ma  $\pm$ 5 ma.

If you have no major deviations in plate current from those given above, your problem is elsewhere.

Before you begin a re-alignment, make sure the 6.36 MHz trap (TC30) is aligned correctly. (See page 7-7, step 7).

After the trap is set, and if you still have unequal power output, go back to step 1, and tune the rig to 28.75 MHz, with 200 ma indicated plate current (IC). Then tune TC2 for maximum. (Leave the carrier control alone).

Go to step 2, and tune up at 29.0 MHz and adjust TC1 for maximum indicated IC.

Go to step 3, and tune up at 28.5 MHz, and adjust TC3 for maximum indicated IC.

Finally, go back to step 1, and reset the IC to 200 ma, and check for equal output across the VFO range by tuning up at several spots between 28.5 and 29.0 MHz.

A certain amount of error might be expected if this is your first experience with aligning band pass filters, so work it over carefully, repeating steps 1, 2, and 3 until you have essentially the same power output across the 500 kHz band segment.

The curve you are trying to achieve is shown below in Fig. 7-10.

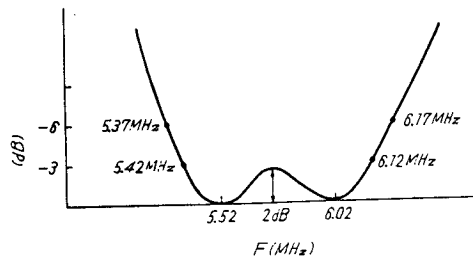
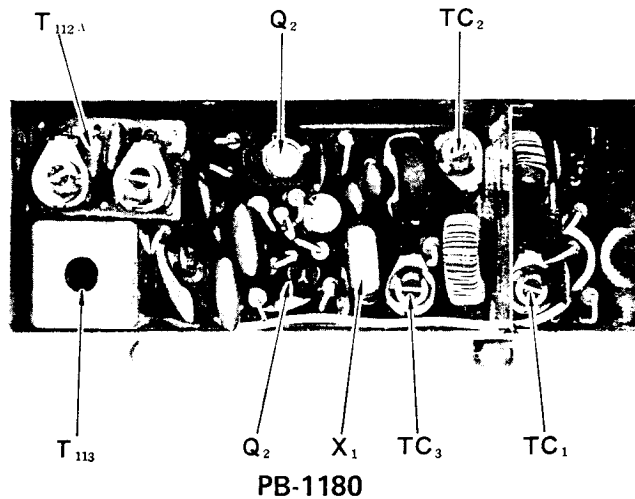

Fig. 7-10

BANDPASS NETWORK CHARACTERISTICS



PARTS LISTS & ORDERING DATA

SECTION 8

<u>CONTENTS</u>	<u>PAGE</u>
PARTS ORDERING DATA . . . . .	8-1
PARTS LIST FT-101 . . . . .	8-3
PARTS LIST FT-101B . . . . .	8-7
PARTS LIST FT-101E/EE/EX . . . . .	8-12

For Service Manuals Contact  
**MAURITRON TECHNICAL SERVICES**  
8 Cherry Tree Rd, Chinnor  
Oxon OX9 4QY  
Tel:- 01844-351694 Fax:- 01844-352554  
Email:- enquiries@mauritron.co.uk

## PARTS LIST AND ORDERING DATA

### Obtaining Replacement Parts

When ordering, you must specify the exact model number of the radio that the part is for.

While many parts are standard, such as disc capacitors and resistors, you should use care when substituting electrolytics, tantalum capacitors, etc.

If in doubt, order and use exact factory replacements using the order form (or a copy of it) in the rear of this section.

The parts list identifies first the board that the parts go on, (or into) then the circuit designator and description. When ordering, use full descriptions as shown in the example.

Example: FT-101E, Main chassis, meter MK 45

FT-101E, Main chassis, transformer T-102 (grid coil A)

FT-101E, PB1292C, FET 2SK19GR (Q3)

FT-101E, PB1314A, IC MFC6030 (IC4) etc.

Shipment is usually made UPS - C.O.D. Allow at least a week for our sterling parts department to perform their magic. You will not be notified that your order has been received, but if parts are back ordered or the order is not clear, they will contact you for advice on how you want it handled.

BLANK PAGE

# FT-101 PARTS

(No. 1 RF UNIT)		PRINTED BOARD	PB-1080A
PRINTED CIRCUIT BOARD PB-1077B		<b>Q-FET, TRANSISTOR &amp; IC</b>	
<b>Q-FET &amp; TRANSISTOR</b>		1	MK-10F
1	3SK39Q	2	2SC784R
3, 5	2SC372Y	6	2SC372Y(2SC828P)
4	2SC784R	4, 5	2SC828Q
<b>RL-RELAY</b>		3	CA-3053
1	SM-12	<b>D-DIODE</b>	
<b>D-DIODE</b>		2, 4, 5, 6, 7, 8, 10, 11, 12, 13, 14, 15, 16	1S1007
1	1S1007	3, 9	1S194I
<b>L-INDUCTOR</b>		<b>L-INDUCTOR</b>	
1	250 $\mu$ H	1, 3, 4, 5, 6	250 $\mu$ H
<b>C-CAPACITOR</b>		<b>T-INDUCTOR</b>	
1, 11	DIPPED MICA 500WV 100P $\pm$ 10%	108	IF COIL
6	500WV 50P $\pm$ 10%	109	DET COIL
2, 8, 9, 10, 12, 14, 15, 16	CERAMIC DISC 50WV 0.01 $\mu$ $\pm$ 100%	<b>VR-POTENTIOMETER</b>	
4	50WV 0.001 $\mu$	1	(BALANCE) VI01KR-I B500 $\Omega$
7	50WV 0.047 $\mu$ $\pm$ 100%	2	(SM-ADJ) VI01KR B500 $\Omega$
<b>R-RESISTOR</b>		3	(NB) VI01KR B10K $\Omega$
1, 5, 16, 17	$\frac{1}{4}$ Wor $\frac{1}{2}$ W 100K $\Omega$ $\pm$ 10%	<b>XF-CRYSTAL FILTER</b>	
2	$\frac{1}{4}$ Wor $\frac{1}{2}$ W 22K $\Omega$ $\pm$ 10%	1	(2.4KHz) XF-30A
3	$\frac{1}{4}$ Wor $\frac{1}{2}$ W 330 $\Omega$ $\pm$ 10%	2	(CW) XF-30C (OPTION)
4, 9	$\frac{1}{4}$ Wor $\frac{1}{2}$ W 1.5K $\Omega$ $\pm$ 10%	<b>C-CAPACITOR</b>	
6	$\frac{1}{4}$ Wor $\frac{1}{2}$ W 2.2K $\Omega$ $\pm$ 10%	35	MYLAR 50WV 0.47 $\mu$ $\pm$ 20%
7, 13	$\frac{1}{4}$ Wor $\frac{1}{2}$ W 470 $\Omega$ $\pm$ 10%	3, 30, 31	DIPPED MICA 500WV 100P $\pm$ 10%
8, 12	$\frac{1}{4}$ Wor $\frac{1}{2}$ W 15K $\Omega$ $\pm$ 10%	6, 17, 23	500WV 470P $\pm$ 10%
10	$\frac{1}{4}$ Wor $\frac{1}{2}$ W 220 $\Omega$ $\pm$ 10%	21, 28	500WV 150P $\pm$ 10%
11	$\frac{1}{4}$ Wor $\frac{1}{2}$ W 3.3K $\Omega$ $\pm$ 10%	39	500WV 5P $\pm$ 10%
14	$\frac{1}{4}$ Wor $\frac{1}{2}$ W 100 $\Omega$ $\pm$ 10%	<b>ELECTROLYTIC</b>	
15	$\frac{1}{2}$ W 560 $\Omega$ $\pm$ 10%	36, 42	16WV 10 $\mu$
18	$\frac{1}{4}$ Wor $\frac{1}{2}$ W 68K $\Omega$ $\pm$ 10%	41	16WV 100 $\mu$
(No. 2 MIXER UNIT)		7, 13, 14, 20, 22	CERAMIC DISC
PRINTED CIRCUIT BOARD PB-1082B		25, 45,	50WV 0.047 $\mu$
PRINTED CIRCUIT BOARD PB-1084C		32, 33, 34	50WV 0.001 $\mu$
<b>Q-FET &amp; TRANSISTOR</b>		4, 5, 8, 9, 10, 11, 12, 15, 16, 18, 19, 24, 26, 27, 29, 37, 38, 40, 43, 44, 46, 47,	50WV 0.01 $\mu$
1	3SK39Q	<b>R-RESISTOR</b>	
2	2SC372Y	28	$\frac{1}{4}$ Wor $\frac{1}{2}$ W 470K $\Omega$ $\pm$ 10%
<b>TC-TRIMMER CAPACITOR</b>		3, 22, 25	$\frac{1}{4}$ Wor $\frac{1}{2}$ W 100K $\Omega$ $\pm$ 10%
1, 2, 3	1ZW50P(MAX)	4, 7, 17, 20	$\frac{1}{4}$ Wor $\frac{1}{2}$ W 100 $\Omega$ $\pm$ 10%
<b>L-INDUCTOR</b>		5, 18	$\frac{1}{4}$ Wor $\frac{1}{2}$ W 2.2K $\Omega$ $\pm$ 10%
1, 3	25T(BPF)	6, 30	$\frac{1}{4}$ Wor $\frac{1}{2}$ W 1.5K $\Omega$ $\pm$ 10%
2	40T(BPF)	31	$\frac{1}{4}$ Wor $\frac{1}{2}$ W 220 $\Omega$ $\pm$ 10%
4	250 $\mu$ H	8, 9	$\frac{1}{4}$ Wor $\frac{1}{2}$ W 5.6K $\Omega$ $\pm$ 10%
<b>T-INDUCTOR</b>		12, 13, 15, 26, 32	$\frac{1}{4}$ Wor $\frac{1}{2}$ W 3.3K $\Omega$ $\pm$ 10%
112A	MIXER COIL	14	$\frac{1}{4}$ Wor $\frac{1}{2}$ W 27K $\Omega$ $\pm$ 10%
113	14MHz TRAP COIL	16, 19, 23, 33	$\frac{1}{4}$ Wor $\frac{1}{2}$ W 1K $\Omega$ $\pm$ 10%
<b>VR-VARIABLE RESISTOR</b>		21, 34, 35, 36	$\frac{1}{4}$ Wor $\frac{1}{2}$ W 10K $\Omega$ $\pm$ 10%
1	SR19R001 B2.2K $\Omega$	24, 27	$\frac{1}{4}$ Wor $\frac{1}{2}$ W 470 $\Omega$ $\pm$ 10%
<b>C-CAPACITOR</b>		29	$\frac{1}{4}$ Wor $\frac{1}{2}$ W 4.7K $\Omega$ $\pm$ 10%
1	DIPPED MICA 500WV 40P $\pm$ 10%	10, 11	$\frac{1}{2}$ W 100 $\Omega$ $\pm$ 10%
2	500WV 470P $\pm$ 10%	(No. 4 AF UNIT)	
6	500WV 100P $\pm$ 10%	PRINTED BOARD PB-1081C	
3, 4, 5, 7, 10, 15	CERAMIC DISC 50WV 0.01 $\mu$ $\pm$ 100%	<b>Q-FET, TRANSISTOR &amp; IC</b>	
9	50WV 0.047 $\mu$ $\pm$ 100%	1	MK-10F
<b>FEED THRU BYPASS</b>		2, 3, 8	2SC372Y (2SC828P)
12, 13, 14	500WV 1000P $\pm$ 100%	5	MK-1D
<b>R-RESISTOR</b>		6, 7	2SC373
1	$\frac{1}{4}$ Wor $\frac{1}{2}$ W 27K $\Omega$ $\pm$ 10%	4	(IC) TA-7042M
2	$\frac{1}{4}$ Wor $\frac{1}{2}$ W 3.3K $\Omega$ $\pm$ 10%	9	(IC) STK401
3	$\frac{1}{4}$ Wor $\frac{1}{2}$ W 1K $\Omega$ $\pm$ 10%	<b>D-DIODE</b>	
4, 8, 11	$\frac{1}{4}$ Wor $\frac{1}{2}$ W 15K $\Omega$ $\pm$ 10%	1, 2, 3, 4	1S194I
5, 6, 10	$\frac{1}{4}$ Wor $\frac{1}{2}$ W 100 $\Omega$ $\pm$ 10%		1S334
7	$\frac{1}{4}$ Wor $\frac{1}{2}$ W 22K $\Omega$ $\pm$ 10%		
12	$\frac{1}{4}$ Wor $\frac{1}{2}$ W 100K $\Omega$ $\pm$ 10%		
13	$\frac{1}{4}$ Wor $\frac{1}{2}$ W 10 $\Omega$ $\pm$ 10%		
(No. 3 IF UNIT)			

# FT-101 PARTS

	110	MOD. COIL
	<b>VR-POTENTIOMETER</b>	
	1	(TX BM) VI01KR - B500Ω
	2	(ALC) VI01KR - B5KΩ
<b>VR-POTENTIOMETER</b>		
1, 5	(VOX)(TONE) VI60KRZ - 1B10KΩ	
2	(DELAY) VI60KRZ - 1B2MΩ	
3	(RELAY) VI01KR B 1KΩ	
4	(ANTI) VI01KR B 10KΩ	
<b>TC-TRIMMER</b>		
	1	1ZW50P (MAX)
	2, 3, 4	1ZW20P (MAX)
<b>C-CAPACITOR</b>		
14	DIPPED MICA	500WV 100P ± 10%
	ELECTROLYTIC	500WV 130P ± 10%
2, 15, 17, 18, 28	16WV 10μ	500WV 150P ± 10%
4, 16, 39, 41	16WV 100μ	500WV 10P ± 10%
5, 6, 7, 10, 13, 19, 31, 34,	16WV 1μ	500WV 200P ± 10%
8, 38, 37, 44, 45, 46	16WV 22μ	500WV 40P ± 10%
36	16WV 47μ	500WV 50P ± 10%
12	16WV 220μ	500WV 300P ± 10%
29, 35, 21	MYLAR	500WV 1000P ± 10%
	50WV 0.1μ ± 20%	
30	50WV 0.0022μ ± 20%	
11	PLASTIC FILM	
	50WV 2.2μ ± 20%	
1, 9, 20, 25, 26, 27, 42	MYLAR	
	50WV 0.01μ ± 20%	
3, 23, 24, 40	50WV 0.047μ ± 20%	
22	50WV 0.022μ ± 20%	
32, 33, 43	50WV 0.001μ ± 20%	
<b>R-RESISTOR</b>		
1, 3, 14, 19, 26, 27,	¼W or ½W 4.7KΩ ± 10%	
2, 33, 35	¼W or ½W 47KΩ ± 10%	
4, 28	¼W or ½W 5.6KΩ ± 10%	
5, 8, 15, 36,	¼W or ½W 1KΩ ± 10%	
6, 34	¼W or ½W 3.3KΩ ± 10%	
7	¼W or ½W 22KΩ ± 10%	
9, 10, 32, 37, 38, 39	¼W or ½W 10KΩ ± 10%	
11, 18	¼W or ½W 15KΩ ± 10%	
12	¼W or ½W 330Ω ± 10%	
13	¼W or ½W 100Ω ± 10%	
16, 17, 30	¼W or ½W 470Ω ± 10%	
41	¼W or ½W 82Ω ± 10%	
20, 31	¼W or ½W 2.2KΩ ± 10%	
21	¼W or ½W 1.5KΩ ± 10%	
23, 24	½W 3.3MΩ ± 10%	
25	¼W or ½W 6.8KΩ ± 10%	
29	¼W or ½W 33KΩ ± 10%	
40	¼W or ½W 220Ω ± 10%	
22	¼W or ½W 470KΩ ± 10%	
42	¼W or ½W 4.7Ω ± 10%	
<b>R-RESISTOR</b>		
1, 3	¼W or ½W 150Ω ± 10%	
2, 21, 30	¼W or ½W 470Ω ± 10%	
4	¼W or ½W 100KΩ ± 10%	
12, 15, 16, 22, 25, 26, 29	¼W or ½W 4.7KΩ ± 10%	
6	¼W or ½W 2.2KΩ ± 10%	
7	¼W or ½W 33KΩ ± 10%	
8	¼W or ½W 3.3KΩ ± 10%	
9, 10, 11, 14, 24, 28	¼W or ½W 1KΩ ± 10%	
13, 17, 23, 27	¼W or ½W 22KΩ ± 10%	
18	¼W or ½W 100Ω ± 10%	
19	¼W or ½W 180Ω ± 10%	
20	¼W or ½W 1.5KΩ ± 10%	
[NO. 6 REG & CALIB UNIT]		
<b>PRINTED BOARD</b>		PB-1079A
<b>Q-TRANSISTOR</b>		
1, 2, 3, 4	2SC735Y (2SC367Y)	
5	2SC697B, D, E	
6	2SC372Y (2SC828P)	
<b>D-DIODE</b>		
1, 4, 5	1S1941	
2	1S993	
3	1S334	
<b>X-CRYSTAL</b>		
1	HC/13U 100KHz	
<b>L-INDUCTOR</b>		
1, 2	4MH	
<b>VR-POTENTIOMETER</b>		
1	(MULTI) VI01KR B 10KΩ	
2	(BIAS) VI60KRZ - 1B10KΩ	
3	(VOLT) VI01KR B 1KΩ	
4	(FREQ. ADJ) VI01KR B500Ω	
<b>TC-TRIMMER</b>		
1	1ZW50P (MAX)	
<b>C-CAPACITOR</b>		
1	DIPPED MICA	
	500WV	250P ± 10%
2	500WV	100P ± 10%
3	500WV	2000P ± 10%
5, 6, 21	500WV	30P ± 10%
7, 8	500WV	1000P ± 10%
9	500WV	40P ± 10%
20	500WV	50P ± 10%
10, 11	ELECTROLYTIC	
	250WV	20μ
12, 13	150WV	20μ
17, 18	25WV	470μF
14, 15, 16,	16WV	1000μ
<b>PRINTED BOARD</b>		
<b>Q-FET &amp; TRANSISTOR</b>		PB-1078A
1	MK-10D	
2, 4	2SC372Y (2SC828P)	
3, 5, 6	2SC372Y	
<b>D-DIODE</b>		
1, 2, 3, 4	1S1007	
<b>X-CRYSTAL</b>		
1	(USB) HC/6U 3178.5KHz	
2	(LSB) HC/6U 3181.5KHz	
3	(CW) HC/6U 3179.3KHz	
<b>L-INDUCTOR</b>		
2, 8, 9	250μH	
3, 4, 6, 7	22μH	
5	10μH	
<b>T-INDUCTOR</b>		

4, 19	CERAMIC DISC 50WV 0.01 $\mu$ $\pm 100\%$	1, 2, 4	50WV 0.01 $\mu$
<b>R-RESISTOR</b>		<b>R-RESISTOR</b>	
1, 8, 13, 15, 24	$\frac{1}{4}$ Wor $\frac{1}{2}$ W10K $\Omega$ $\pm 10\%$	1, 5	$\frac{1}{4}$ Wor $\frac{1}{2}$ W100K $\Omega$ $\pm 10\%$
2, 9	$\frac{1}{4}$ Wor $\frac{1}{2}$ W100K $\Omega$ $\pm 10\%$	2	$\frac{1}{4}$ Wor $\frac{1}{2}$ W56 $\Omega$ $\pm 10\%$
3, 10	$\frac{1}{4}$ Wor $\frac{1}{2}$ W100 $\Omega$ $\pm 10\%$	3	$\frac{1}{4}$ Wor $\frac{1}{2}$ W100 $\Omega$ $\pm 10\%$
4, 7, 11	$\frac{1}{4}$ Wor $\frac{1}{2}$ W4.7K $\Omega$ $\pm 10\%$	(NO. 9 REC UNIT)	
5	$\frac{1}{4}$ Wor $\frac{1}{2}$ W27K $\Omega$ $\pm 10\%$	PRINTED BOARD PB-1076B	
6	$\frac{1}{4}$ Wor $\frac{1}{2}$ W33K $\Omega$ $\pm 10\%$	<b>D-DIODE</b>	
12	$\frac{1}{4}$ Wor $\frac{1}{2}$ W1.5K $\Omega$ $\pm 10\%$	1, 2, 3, 4, 9, 10, 11, 12	10D10
14	$\frac{1}{4}$ Wor $\frac{1}{2}$ W47K $\Omega$ $\pm 10\%$	5, 6	1S1942
17, 19	$\frac{1}{4}$ Wor $\frac{1}{2}$ W330 $\Omega$ $\pm 10\%$	7, 8	10D1
18	$\frac{1}{4}$ Wor $\frac{1}{2}$ W1K $\Omega$ $\pm 10\%$	<b>C-CAPACITOR</b>	
22	$\frac{1}{4}$ Wor $\frac{1}{2}$ W3.3K $\Omega$ $\pm 10\%$	1, 2, 5	CERAMIC DISC $\pm 100\%$ 1.4KVDC 0.0047 $\mu$ $\pm 0\%$
23	$\frac{1}{4}$ Wor $\frac{1}{2}$ W2.2K $\Omega$ $\pm 10\%$	4,	500WV 0.01 $\mu$ $\pm 100\%$
20	$\frac{1}{4}$ Wor $\frac{1}{2}$ W2K $\Omega$ $\pm 5\%$	6,	50WV 0.047 $\mu$ $\pm 100\%$
16	1W 4.7K $\Omega$ $\pm 10\%$	3	<b>ELECTROLYTIC</b> 25WV 470 $\mu$
(NO. 7 VFO UNIT)		<b>R-RESISTOR</b>	
PRINTED BOARD PB-1056		1	2W 5.6 $\Omega$ $\pm 10\%$
<b>Q-FET &amp; TRANSISTOR</b>		2	$\frac{1}{2}$ W 1K $\Omega$ $\pm 10\%$
1, 2	3SK22G	4, 5	1W 3.3 $\Omega$ $\pm 10\%$
3	2SC372Y (2SC828P)	3	10W 47 $\Omega$ $\pm 10\%$
<b>D-DIODE</b>		6~13	$\frac{1}{4}$ Wor $\frac{1}{2}$ W 470K $\Omega$ $\pm 10\%$
1	1S145	(NO. 10 MAIN CHASSIS)	
<b>L-INDUCTOR</b>		PRINTED BOARD PB-1075B	
1	(OSC COIL) 3.3 $\mu$ H	PRINTED BOARD PB-1092	
2, 3, 4, 6, 7	250 $\mu$ H	PRINTED BOARD PB-1086A $\times 2$	
5	(RFC) 0.06/4 32T	PRINTED BOARD PB-1073A	
<b>VC-VARIABLE CAPACITOR</b>		PRINTED BOARD PB-1074A	
1	B5240DS	PRINTED BOARD PB-1083A	
<b>TC-TRIMMER</b>		PRINTED BOARD PB-1107	
1	150C 30P	PRINTED BOARD PB-1109	
2	170C 10P $\times 2$	PRINTED BOARD PB-1116	
<b>C-CAPACITOR</b>		<b>V-VACUUM TUBE</b>	
1, 2	DIPPED-MICA 500WV 650P $\pm 10\%$	1	12BY7A
8, 10	500WV 100P $\pm 10\%$	2, 3	6JS6A
*11	500WV 2000P $\pm 10\%$	<b>D-DIODE</b>	
16	500WV 20P $\pm 10\%$	1, 2, 3	1S1941
4	CERAMIC NPO 500WV 10P	4, 7, 8, 10, 11, 13	1S1007
14	500WV 6P	9	1S334
19	500WV 82P	<b>Q-TRANSISTOR</b>	
*17	CERAMIC UJ 500WV 20P	1, 2	DTG-110B
*18	500WV 7P	<b>M-METER</b>	
20	500WV 2P	1	TYPE-45 500 $\mu$ A
3, 5, 13	CERAMIC DISC 500WV 0.01 $\mu$	<b>S-SWITCH</b>	
6, 7, 9, 12, 15	50WV 0.01 $\mu$ $\pm 100\%$	1	(BAND) 12-12-11
<b>R-RESISTOR</b>		2	(MODE) ESR-E365R20Z
1	$\frac{1}{4}$ Wor $\frac{1}{2}$ W10K $\Omega$ $\pm 10$	3, 10	(SLIDE) SS-F-22-08
2, 5	$\frac{1}{4}$ Wor $\frac{1}{2}$ W100K $\Omega$ $\pm 10\%$	4	(SELECT) ESR-E246R20Z
3, 6	$\frac{1}{4}$ Wor $\frac{1}{2}$ W330 $\Omega$ $\pm 10\%$	5	(HEATER) WD-3201
4, 7	$\frac{1}{4}$ Wor $\frac{1}{2}$ W100 $\Omega$ $\pm 10\%$	6	(POWER) WD-3001
8	$\frac{1}{4}$ Wor $\frac{1}{2}$ W8.2K $\Omega$ $\pm 10\%$	7, 8, 9	(SLIDE) SS-H-23-08
9	$\frac{1}{4}$ Wor $\frac{1}{2}$ W22K $\Omega$ $\pm 10\%$	<b>RL-RELAY</b>	
10	$\frac{1}{4}$ Wor $\frac{1}{2}$ W270 $\Omega$ $\pm 10\%$	1	NK-6 (AE3171)
11	$\frac{1}{2}$ W 1K $\Omega$ $\pm 10\%$	2	MX-2
(NO. 8 FIX UNIT)		<b>X-CRYSTAL</b>	
PRINTED BOARD PB-1060A		1	80M HC/25U 9.520MHz
<b>Q-FET</b>		2	40M HC/25U 13.020MHz
1	MK-10Eor F	3	20M HC/25U 20.020MHz
<b>D-DIODE</b>		4	15M HC/25U 27.020MHz
1	1S145	6	(10A) HC/25U 34.020MHz
<b>L-INDUCTOR</b>		7	(10B) HC/25U 34.520MHz
1	OUT COIL	8	(10C) HC/25U 35.020MHz
2	(RFC) 250 $\mu$ H	9	(10D) HC/25U 35.520MHz
<b>TC-TRIMMER</b>		10	WWV HC/25U 16.020MHz
1, 2	1ZW20P (MAX)	5	CB HC/25U 33.020MHz
<b>C-CAPACITOR</b>		11	(AUX OPTION) HC/25U
3	DIPPED MICA 500WV 60P $\pm 10\%$	<b>VS-VACUUM TUBE SOCKET</b>	
5	500WV 20P $\pm 10\%$	1	(9P) TS-103 COI
	CERAMIC DISC	2, 3	(12P) SB-0703
		<b>J-JACK</b>	
		1, 4, 5, 7, 8, 11	RCA CN7017
		2, 10	SG7615 (2P)
		3	FM-144 (4P)

# FI-101 PARTS

6	J50-239 (INCH)	3	14V 30mA (LEAD LAMP)
9	450-AB12M (12P)	<b>C-CAPACITOR</b>	
12	P2240	1, 16, 107	DIPPED MICA
13	S-B0611 (8P)		500WV 10P ± 10%
14	SA-602B (11P)	2, 26, 29	500WV 470P ± 10%
15	S-16303 (4P)	105	500WV 200P ± 10%
<b>P-PLUG</b>		7, 27, 120, 121	500WV 1000P ± 10%
1, 4, 5, 7, 8, 11	RCA CN7017	28, 98, 126	500WV 5P ± 10%
2, 10	SH-3001 (2P)	48, 53, 55, 92, 99	500WV 100P ± 10%
3	SH-3601 (3P)	122	500WV 30P ± 10%
6	M-P-7 (INCH)	4, 41	500WV 330P ± 10%
9	450-PI2F	6, 43	500WV 70P ± 10%
12	P2240 (USPLUG)	9	500WV 270P ± 10%
13	S-10401 (8P)	10, 42, 47, 5	500WV 50P ± 10%
14	PA-602B (11P)	44, 97, 106	500WV 20P ± 10%
<b>MJ-MULTI JACK</b>		108	500WV 400P ± 10%
1, 2, 6	SI-4701 (18P)	104	500WV 80P ± 10%
3, 4	XI-8007 (22P)	45	500WV 300P ± 10%
5	SI-4703 (14P)	46, 111	500WV 150P ± 10%
<b>F-FUSE</b>		123	500WV 2PF ± 0.5P
1	AC 100~117V 5A	17	MICA 1KWV 2200P
	AC 200~220V 3A	76	MP 160WV 2.2μ ± 20%
2	DC 13V 20A	49	MYLAR
<b>FH-FUSE HOLDER</b>			50WV 0.47μ ± 20%
1	(AC) SN-1001	18	50WV 0.22μF ± 20%
	(DC) SN-1102	13, 125	MICA 1KWV 100P
<b>L-INDUCTOR</b>		11	1KWV 200P
1, 4 (P.S.)	½W56Ω 0.6φ2TS	23	1.5KWV 1000P
5, 6 (P.S.)	1W56Ω 1φ4TS	25	CERAMIC RDA30 150P ± 10%
2, 3, 11, 14, 15	RFC TV-245	54	ELECTROLYTIC 16WV 10μ
7	PLATE RFC	57	16WV 100μ
8	TANK COIL	116	16WV 1μ
9	RFC 300μH	63	16WV 220μ
12, 13, 16~21, 23, 26, 27, 31	250μH	127	16WV 470μ
22	28.6MHz TRAP	124	25WV 1000μ
24 (P.S.)	½W56Ω 0.3φ10TS	109	450WV 2.2μ
25	L.P. FILTER	77, 78	500WV 100μ
28, 29	TRAP	30, 31, 32, 39, 40, 67	FEED THROUGH BYPASS
<b>T-INDUCTOR</b>		68, 84, 37, 34, 35, 110	500WV 1000P ± 10%
101A	ANT COIL A	33, 38, 50, 52, 56, 58, 59, 60	CERAMIC DISC
102	GRID COIL A	61, 66, 70, 71, 72, 73, 85, 89	50WV 0.047μ ± 10%
103	DRIVE COIL A	91, 94, 95, 96, 100, 103, 119	
104	ANT COIL B	51, 69, 62, 81, 82	50WV 0.01μ ± 10%
105	GRID COIL B	83, 86, 87, 88, 90, 118	
106	DRIVE COIL B	3, 19, 21, 101, 102	500WV 0.01μ ± 10%
111	LOCAL COIL	8, 14, 15, 20, 22, 93	500WV 0.0047μ ± 10%
107	5MHz TRAP	24	1.4KV DC 4700P ± 10%
114	6.36 MHz TRAP	36, 75	1.4KV DC 0.01μ ± 10%
115	3.18MHz TRAP	74	1.4KVDC 0.001μ ± 10%
<b>T-TRANSFORMER</b>		<b>R-RESISTOR</b>	
11	POWER TRANS	2	½ W 3.3KΩ ± 10%
12	20mH 0.5A CHOKE	3	½ W 47KΩ ± 10%
14	1H 20mA CHOKE	4, 9, 17, 39	½ W 56Ω ± 10%
<b>TC-TRIMMER</b>		14, 21, 51, 52	½ W 100Ω ± 10%
1~4, 11~26, 28, 29	1ZW 50P (MAX)	6	½ W 2.2KΩ ± 10%
5	1ZW 10P (MAX)	7, 38, 49	½ W 1KΩ ± 10%
6, 7, 10	B-2PY 100P (MAX)	8, 25	½ W 10KΩ ± 10%
8, 9	B-1PY 40P (MAX)	28, 29	½ W 470KΩ ± 10%
27	150C 10P 1.5KV	16, 18	½ W 470Ω ± 10%
<b>VC-VARIABLE CAPCITOR</b>		19, 20, 23, 24, 31, 32, 33, 34	½ W 5.6KΩ ± 10%
1	(PLATE) RT-18B-300VC	22	½ W 330Ω ± 10%
2	(LOADING) BI240 DS	26	½ W 560Ω ± 10%
<b>VR-POTENTIOMETER</b>		35	½ W 680Ω ± 10%
1	(AF-RF GAIN) EVK-A8AF02314	10, 11	1W 56Ω ± 10%
		30	1W 47KΩ ± 10%
2	(MIC GAIN CARRIER) EVK-AOAF02339	12	M-1 SHUNT
		5	3W 5.1KΩ ± 5%
3	(CLARIFIER) ECVBOHS15A14	37	5W 18KΩ ± 10%
4	VI01KR B1KΩ	40	5W 1.5KΩ ± 10%
7	EVLS3AA00B53	※44	½ W 4.7KΩ ± 10%
6	(PO ADJ) EVHBOAS15BI3	36	½ W 33KΩ ± 10%
<b>SP-SPEAKER</b>		1	½ W 22KΩ ± 10%
1	B-26 VC 4~8Ω	13	½ W 1MΩ ± 10%
<b>PL-PILOT LAMP</b>		48	½ W 220Ω ± 10%
1, 2	15V SWAN	50	½ W 1.5KΩ ± 10%

# FT-101-B PARTS

RF UNIT				C-CAPACITOR			
PRINTED CIRCUIT BOARD PB-1181(A~Z)				DIPPED MICA			
Q-FET & TRANSISTOR				6, 19	50 WV	20PF ± 10%	
4	TR.	2SC372Y		1, 8	50 WV	40PF ± 10%	
5	TR.	2SC373		8	50 WV	100PF ± 10%	
3	TR.	2SC784R		2	50 WV	470PF ± 10%	
2	FET	2SK19GR		CERAMIC DISC			
1	FET	3SK40M		7	50 WV	0.001 μF	+ 80% - 20%
				3~5, 9, 11, 13	50 WV	0.01 μF	+ 80% - 20%
D-DIODE				17	50 WV	0.047 μF	+ 80% - 20%
1, 2	Si.	1S1555					
R-RESISTOR				CERAMIC FEED THRU			
CARBON FILM				14~16	500 WV	0.001 μF	+ 100% 0%
22	¼ W	56 Ω ± 10%		ELECTROLYTIC			
23	¼ W	100 Ω ± 10%		18	16 WV	1 μF	
16, 24	¼ W	220 Ω ± 10%		TC-TRIMMER CAPACITOR			
6	¼ W	330 Ω ± 10%		CERAMIC			
10, 19	¼ W	470 Ω ± 10%		1~3	ECV1ZW50P32	50 PF	
11	¼ W	560 Ω ± 10%		L-INDUCTOR			
9, 13	¼ W	1 KΩ ± 10%		1	BPF-A		
7	¼ W	1.8 KΩ ± 10%		2	BPF-B		
8	¼ W	2.2 KΩ ± 10%		3	BPF-C		
17, 20	¼ W	3.3 KΩ ± 10%		34	RF CHOKE	1.95 μH	
21	¼ W	8.2 KΩ ± 10%		4, 8	RF CHOKE	250 μH	
14, 18	¼ W	15 KΩ ± 10%		T-TURNFORMER & INDUCTOR			
2	¼ W	22 KΩ ± 10%		112A	IF TRANSFORMER		
4	¼ W	82 KΩ ± 10%		113	TRAP COIL		
1, 3, 5, 12	¼ W	100 KΩ ± 10%		X-CRYSTAL			
				1	HC-18/U	6360 KHz	
VR-VARIABLE RESISTOR							
1	TR-11R	5KΩB		IF UNIT			
C-CAPACITOR				PRINTED CIRCUIT BOARD PB-1183(A~Z)			
DIPPED MICA				Q-FET, IC & TRANSISTOR			
17	50 WV	6PF ± 0.5PF		2	TR.	2SC784R	
5	50 WV	50PF ± 10%		4, 5	TR.	2SC828Q	
1, 11	50 WV	100PF ± 10%		3	IC	CA3053	
CERAMIC DISC				1	FET	2SK19GR	
3	50 WV	0.001 μF	+ 80% - 20%	D-DIODE			
2, 4, 7~10, 12~16,	50 WV	0.01 μF	+ 80% - 20%	1~5, 7~11	Ge.	1S1007	
6, 18	50 WV	0.047 μF	+ 80% - 20%	6	Si.	1S1555	
ELECTROLYTIC				12	Zener	WZ-110	
19	16 WV	47 μF		R-RESISTOR			
L-INDUCTOR				CARBON FILM			
1, 2	RF CHOKE	1mH		2, 13, 16	¼ W	100 Ω ± 10%	
3	RF CHOKE	250mH		23	¼ W	220 Ω ± 10%	
MIXER UNIT				20	¼ W	470 Ω ± 10%	
PRINTED CIRCUIT BOARD PB-1082(A~Z) PB-1180(A~Z)				12, 15, 19	¼ W	1 KΩ ± 10%	
Q-FET & TRANSISTOR				3, 14	¼ W	2.2 KΩ ± 10%	
1	TR.	2SC372Y		22	¼ W	2.7 KΩ ± 10%	
2	FET	3SK40M		8, 9	¼ W	3.3 KΩ ± 10%	
D-DIODE				11	¼ W	3.9 KΩ ± 10%	
1	Si.	1S1555		4, 5	¼ W	5.6 KΩ ± 10%	
R-RESISTOR				17, 24, 25, 27	¼ W	10 KΩ ± 10%	
CARBON FILM				10	¼ W	27 KΩ ± 10%	
12	¼ W	10 Ω ± 10%		1, 18, 21	¼ W	100 KΩ ± 10%	
5, 7	¼ W	100 Ω ± 10%		CARBON COMPOSITION			
13	¼ W	470 Ω ± 10%		26	¼ W	1 MΩ ± 10%	
3, 16, 17	¼ W	1 KΩ ± 10%		6, 7	½ W	100 Ω ± 10%	
2	¼ W	4.7 KΩ ± 10%		VR-VARIABLE RESISTOR			
14, 15	¼ W	5.6 KΩ ± 10%		1	TRI2R	500ΩB	
10	¼ W	10 KΩ ± 10%		2	TRI1R	500ΩB	
4, 6	¼ W	15 KΩ ± 10%		C-CAPACITOR			
11	¼ W	22 KΩ ± 10%		DIPPED MICA			
1	¼ W	27 KΩ ± 10%		1, 24, 25	50 WV	100PF ± 10%	
8	¼ W	100 KΩ ± 10%					
9	¼ W	220 KΩ ± 10%					



# FT-101-B PARIS

15, 22	50WV	150PF ± 10%	<b>ELECTROLYTIC</b>	
11, 17	50WV	470PF ± 10%	5, 6, 7, 10, 14, 21	16WV 1 μF
<b>CERAMIC DISC</b>			11	16WV 2.2 μF
26 ~ 28	50WV	0.001 μF ± 80% - 20%	2, 16, 19, 20, 31, 36	16WV 10 μF
2 ~ 6, 9, 10, 12, 13, 18, 20,	50WV	0.01 μF ± 80% - 20%	8, 35	16WV 22 μF
21, 23, 31 ~ 34			40	16WV 33 μF
7, 8, 14, 16, 19, 35	50WV	0.047 μF ± 80% - 20%	4, 18, 38, 42, 49	16WV 100 μF
			13, 41, 44	16WV 220 μF
<b>PLASTIC FILM</b>				
29	50WV	0.47 μF ± 20%		
<b>ELECTROLYTIC</b>				
30	16WV	10 μF		
<b>L-INDUCTOR</b>				
1 ~ 4		250 μH	<b>MOD &amp; OSC UNIT</b>	
<b>T-TRANSFORMER &amp; INDUCTOR</b>			<b>PRINTED CIRCUIT BOARD PB-1184(A ~ Z)</b>	
108	<b>IF TRANSFORMER</b>		<b>Q-FET &amp; TRANSISTOR</b>	
109	<b>IF TRANSFORMER(DETECTOR)</b>		2, 3, 5, 6	TR. 2SC372Y
<b>XF-CRYSTAL FILTER</b>			4	TR. 2SC828P
1	<b>XF-32A SSB</b>		1	FET. 2SK19Y
2	<b>XF-30C CW(OPTION)</b>		<b>D-DIODE</b>	
			1 ~ 4	Ge. 1S1007
<b>AF UNIT</b>				
<b>PRINTED CIRCUIT BOARD PB1315(A ~ Z)</b>			<b>R-RESISTOR</b>	
<b>Q-FET, IC &amp; TRANSISTOR</b>			<b>CABON FILM</b>	
2, 3,	2SC372Y		18	¼W 100 Ω ± 10%
6, 7	2SC373		1, 3	¼W 150 Ω ± 10%
9	2SC1000		19	¼W 180 Ω ± 10%
1	2SK19GR		2, 21, 30	¼W 470 Ω ± 10%
5	2SK19Y		9 ~ 11, 14, 24, 28	¼W 1 KΩ ± 10%
8	AN214		20	¼W 1.5KΩ ± 10%
4	TA-7045M		6, 8	¼W 2.2KΩ ± 10%
<b>DIODE</b>			12, 15, 16, 22, 25, 26, 29	¼W 4.7KΩ ± 10%
1, 2, 3, 4	1S1555		32	¼W 10 KΩ ± 10%
5	WZ-090		33	¼W 15 KΩ ± 10%
<b>RESISTOR</b>			13, 17, 23, 27	¼W 22 KΩ ± 10%
13, 14	¼W	100 Ω ± 10%	7	¼W 33 KΩ ± 10%
53	¼W	120 Ω ± 10%	4	¼W 100 KΩ ± 10%
41	¼W	220 Ω ± 10%	<b>VR-VARIABLE RESISTOR</b>	
12	¼W	330 Ω ± 10%	1	TRIIR 500ΩB
16, 17, 33	¼W	470 Ω ± 10%	2	TRIIR 5KΩB
45	¼W	560 Ω ± 10%	<b>C-CAPACITOR</b>	
27	¼W	680 Ω ± 10%	<b>DIPPED MICA</b>	
5, 8, 15, 45, 49	¼W	1 KΩ ± 10%	20, 28, 30	50WV 30PF ± 10%
21	¼W	1.5KΩ ± 10%	19, 27, 32	50WV 40PF ± 10%
20, 28, 34	¼W	2.2KΩ ± 10%	38	50WV 50PF ± 10%
6	¼W	3.3KΩ ± 10%	5, 10, 37	50WV 100PF ± 10%
1, 3, 14, 29 ~ 31, 38, 39, 40	¼W	4.7KΩ ± 10%		
4, 48	¼W	5.6KΩ ± 10%	4	50WV 150PF ± 10%
9, 10, 35	¼W	10 KΩ ± 10%	21	50WV 300PF ± 10%
51	¼W	12 KΩ ± 10%	23, 36	50WV 1000PF ± 10%
11, 18	¼W	15 KΩ ± 10%	<b>CERAMIC DISC</b>	
7, 52	¼W	22 KΩ ± 10%	31	50WV 0.001 μF ± 80% - 20%
43, 47	¼W	27 KΩ ± 10%	2, 8, 9, 13, 17, 18, 24,	50WV 0.01 μF ± 80% - 70%
32, 42	¼W	33 KΩ ± 10%	26, 29, 33	
50	¼W	39 KΩ ± 10%	6, 11, 22, 25, 34	50WV 0.047 μF ± 80% - 20%
2, 36, 37, 46	¼W	47 KΩ ± 10%	<b>PLASTIC FILM</b>	
22	¼W	470 KΩ ± 10%	12	50WV 0.22 μF ± 20%
23, 24	½W	3.3MΩ ± 10%	<b>ELECTROLYTIC</b>	
25,	½W	5.6MΩ ± 10%	15	16WV 100 μF
26	<b>THERMISTOR SDT250</b>			
<b>VR-VARIABLE RESISTOR</b>			<b>TC-TRIMMER CAPACITOR</b>	
3, 4	TR-11R	10KΩB	<b>CERAMIC</b>	
1, 5	V160KRZ-1	10KΩB	2 ~ 4	ECVIZW20P40 20PF
2	V160KRZ-1	2MΩB	1, 5, 6	ECVIZW50P40 50PF
<b>C-CAPACITOR</b>			<b>L-INDUCTOR</b>	
46	DIPPED MICA	50WV 100 PF ± 10%	5	RF CHOKE 10 μH
15, 27, 51, 52	MYLAR	50WV 0.001 μF ± 20%	2 ~ 4, 6, 7	RF CHOKE 22 μH
47		50WV 0.0047 μF ± 20%	8, 9	RF CHOKE 250 μH
1, 9, 12, 17, 22, 33, 34	50WV	0.01 μF ± 20%		
24, 28, 29, 30, 39	50WV	0.022 μF ± 20%		
3, 25, 26, 48, 50	50WV	0.047 μF ± 20%		
23, 32, 37, 43, 45	50WV	0.1 μF ± 20%		

<b>T-TRANSFORMER</b>			<b>D-DIODE</b>		
110	IF TRANSFORMER		1~3	Si	1S1555
<b>X-CRYSTAL</b>			4	Zener	WZ090
1	HC-6/U 3178.5KHz(USB)		<b>R-RESISTOR</b>		
2	HC-6/U 3181.5KHz(LSB)		CARBON FILM		
3	HC-6/U 3179.3KHz(CW/AM)		4, 13	$\frac{1}{4}$ W	100 $\Omega \pm 10\%$
			16	$\frac{1}{4}$ W	330 $\Omega \pm 10\%$
			3	$\frac{1}{4}$ W	560 $\Omega \pm 10\%$
			6, 8, 12, 19	$\frac{1}{4}$ W	1 K $\Omega \pm 10\%$
<b>REG. &amp; CALIB. UNIT</b>			18	$\frac{1}{4}$ W	1.5K $\Omega \pm 10\%$
PRINTED CIRCUIT BOARD PB-1314(A~Z)			15	$\frac{1}{4}$ W	2.2K $\Omega \pm 10\%$
<b>Q-TRANSISTOR &amp; IC</b>			9, 11, 21, 22	$\frac{1}{4}$ W	3.3K $\Omega \pm 10\%$
1, 3	TR.	2SC735Y	1	$\frac{1}{4}$ W	4.7K $\Omega \pm 10\%$
2	IC	MFC-6020	23	$\frac{1}{4}$ W	15 K $\Omega \pm 10\%$
4	IC	MFC-6030A~4A	2, 10	$\frac{1}{4}$ W	22 K $\Omega \pm 10\%$
<b>D-DIODE</b>			5, 7, 14, 17, 20	$\frac{1}{4}$ W	100 K $\Omega \pm 10\%$
1, 2, 3	Si	1S1555	<b>VR-VARIABLE RESISTOR</b>		
<b>R-RESISTOR</b>			1	TRIIR	10K $\Omega$ B
CARBON FILM			<b>C-CAPACITOR</b>		
3, 6	$\frac{1}{4}$ W	100 $\Omega \pm 10\%$	DIPPED MICA		
10, 19, 20	$\frac{1}{4}$ W	470 $\Omega \pm 10\%$	1	50WV	3PF $\pm 0.5$ PF
8	$\frac{1}{4}$ W	560 $\Omega \pm 10\%$	13	50WV	6PF $\pm 1$ PF
7, 21	$\frac{1}{4}$ W	680 $\Omega \pm 10\%$	3, 9, 16, 18	50WV	30PF $\pm 10\%$
16	$\frac{1}{4}$ W	1.5K $\Omega \pm 10\%$	12	50WV	50PF $\pm 10\%$
17	$\frac{1}{4}$ W	4.7K $\Omega \pm 10\%$	11, 21, 22	50WV	100PF $\pm 10\%$
1, 4, 13, 15, 18	$\frac{1}{4}$ W	10 K $\Omega \pm 10\%$	2, 4, 8, 15	50WV	130PF $\pm 10\%$
2	$\frac{1}{4}$ W	15 K $\Omega \pm 10\%$	CERAMIC DISC		
14	$\frac{1}{4}$ W	47 K $\Omega \pm 10\%$	5, 10, 14, 17, 19, 20, 24,	50WV	0.01 $\mu$ F $\pm \begin{matrix} 80\% \\ 20\% \end{matrix}$
2, 5	$\frac{1}{4}$ W	100 K $\Omega \pm 10\%$	25, 28, 29		
CARBON COMPOSITION			6, 26, 27	50WV	0.047 $\mu$ F $\pm \begin{matrix} 80\% \\ 20\% \end{matrix}$
9	$\frac{1}{2}$ W	4.7 $\Omega \pm 10\%$	ELECTROLYTIC		
11	2W	6.8K $\Omega \pm 10\%$	7, 23	16WV	1 $\mu$ F
<b>VR-VARIABLE RESISTOR</b>			<b>TC-TRIMMER CAPACITOR</b>		
4	TRIIR	500 $\Omega$ B	CERAMIC		
3	TRIIR	1K $\Omega$ B	1~4	ECVIZW50P40	50PF
2	V160KRZ-1	10K $\Omega$ B	<b>L-INDUCTOR</b>		
<b>C-CAPACITOR</b>			2	RF CHOKE	250 $\mu$ H
DIPPED MICA			1, 3~5	RF CHOKE	1mH
7~9	50WV	30PF $\pm 10\%$	<b>T-TRANSFORMER</b>		
5, 10	50WV	40PF $\pm 10\%$	116~119	IF TRANSFORMER R124129	
1	50WV	100PF $\pm 10\%$	<b>FIX UNIT</b>		
2	50WV	250PF $\pm 10\%$	PRINTED CIRCUIT BOARD PB-1344(A~Z)		
3	50WV	2000PF $\pm 10\%$	<b>Q-FET</b>		
CERAMIC DISC			1	FET	2SK19GR
4, 6	50WV	0.01 $\mu$ F	<b>D-DIODE</b>		
PLASTIC FILM			1	Varactor	1S145
17	50WV	0.001 $\mu$ F	<b>R-RESISTOR</b>		
15	50WV	0.1 $\mu$ F	CARBON FILM		
20	250WV	0.047 $\mu$ F	2	$\frac{1}{4}$ W	56 $\Omega \pm 10\%$
ELECTROLYTIC			3	$\frac{1}{4}$ W	100 $\Omega \pm 10\%$
13, 14	16WV	1000 $\mu$ F	1, 4	$\frac{1}{4}$ W	100K $\Omega \pm 10\%$
16	16WV	100 $\mu$ F	<b>C-CAPACITOR</b>		
11, 12	25WV	1000 $\mu$ F	DIPPED MICA		
21	150WV	22 $\mu$ F	5	50WV	20PF $\pm 10\%$
18, 19, 22	250WV	22 $\mu$ F	3	50WV	50PF $\pm 10\%$
<b>TC-TRIMMER CAPACITOR</b>			CERAMIC DISC		
CERAMIC			1, 2, 4	50WV	0.01 $\mu$ F $\pm \begin{matrix} 80\% \\ 20\% \end{matrix}$
1	ECVIZW50P40	50PF	<b>L-INDUCTOR</b>		
<b>L-INDUCTOR</b>			2	RF CHOKE	250 $\mu$ H
1, 2	RF CHOKE	4mH	1	FIX OUTPUT COIL	
<b>X-CRYSTAL</b>			<b>VFO UNIT</b>		
1	HC-13/U	100KHz	PRINTED CIRCUIT BOARD PB-1056(A~Z)		
<b>NB UNIT</b>			<b>Q-FET &amp; TRANSISTOR</b>		
PRINTED CIRCUIT BOARD PB-1292(A~Z)			3	TR.	2SC372Y
<b>Q-FET &amp; TRANSISTOR</b>			1, 2	FET	2SK19GR
1, 6	TR.	2SC372Y	<b>D-DIODE</b>		
4	TR.	2SC784R	1	Varactor	1S145
2, 3, 5	FET	2SK19GR	<b>R-RESISTOR</b>		
			CARBON FILM		
			4, 7	$\frac{1}{4}$ W	100 $\Omega \pm 10\%$
			10	$\frac{1}{4}$ W	270 $\Omega \pm 10\%$
			3, 6	$\frac{1}{4}$ W	330 $\Omega \pm 10\%$
			8	$\frac{1}{4}$ W	8.2K $\Omega \pm 10\%$

1	1/4W	10	KΩ ±10%	1-3, 8, 11-13	Si.	IS1555
9	1/4W	22	KΩ ±10%	14	Si.	IS1555
2, 5	1/4W	100	KΩ ±10%	9	Zener	WZ-090
<b>CARBON COMPOSITION</b>				<b>R-RESISTOR</b>		
11(L5)	1/2W	1	KΩ ±10%	<b>CARBON FILM</b>		
				48	1/4W	220 Ω ±10%
				22	1/4W	330 Ω ±10%
				18	1/4W	470 Ω ±10%
				26, 63	1/4W	560 Ω ±10%
				64, 65, 68	1/4W	1KΩ ±10%
				50	1/4W	1.5KΩ ±10%
				70	1/4W	3.3KΩ ±10%
				61, 64	1/4W	4.7KΩ ±10%
				23, 24, 33, 34	1/4W	5.6KΩ ±10%
				25, 59	1/4W	10 KΩ ±10%
				60	1/4W	33KΩ ±10%
<b>C-CAPACITOR</b>				<b>CARBON COMPOSITION</b>		
				54	1/2W	10 Ω ±10%
				4, 9, 17, 39, 69	1/2W	56 Ω ±10%
				14, 51, 53, 55	1/2W	100 Ω ±10%
				16	1/2W	470 Ω ±10%
				35	1/2W	680 Ω ±10%
				7, 38, 66	1/2W	1 KΩ ±10%
				6, 67	1/2W	2.2KΩ ±10%
				2	1/2W	3.3KΩ ±10%
				44	1/2W	7KΩ ±10%
				19, 20	1/2W	5.6KΩ ±10%
				8	1/2W	10 KΩ ±10%
				36, 56	1/2W	33 KΩ ±10%
				3	1/2W	47 KΩ ±10%
				28, 29	1/2W	470 KΩ ±10%
				13	1/2W	1 MΩ ±10%
				10, 11	1 W	56 Ω ±10%
				<b>METALIC FILM</b>		
				30	1 W	47 KΩ ±10%
				5	3 W	5.1KΩ ±10%
				40	5 W	1.5KΩ ±10%
				37	5 W	18 KΩ ±10%
				<b>WIRE WOUND</b>		
				<b>METER SHUNT</b>		
				<b>VR-VARIABLE RESISTOR</b>		
				3	EVCBOQS20B13	1KΩB
				6	EVHBOAS15B13	1KΩB
				1	EVKA2AF02314	5KΩA/1KΩB
				2	EVKA2AF01339	5KΩA/5KΩP
				4	TR-11R	500ΩL
				<b>C-CAPACITOR</b>		
				<b>DIPPED MICA</b>		
				123	500WV	2PF ±0.5PF
				134	500WV	3PF ±0.5PF
				28	500WV	5PF ±0.5PF
				1, 16, 98, 107	500WV	10PF ±10%
				44	500WV	20PF ±10%
				97, 106, 122	500WV	30PF ±10%
				5, 6, 10, 42, 43, 47	500WV	50PF ±10%
				135	500WV	60PF ±10%
				48, 53, 55, 92, 99	500WV	100PF ±10%
				46, 111	500WV	150PF ±10%
				29	500WV	200PF ±10%
				4, 9, 127	500WV	250PF ±10%
				41,	500WV	270PF ±10%
				45	500WV	300PF ±10%
				105, 108	500WV	400PF ±10%
				2, 26, 136	500WV	470PF ±10%
				128, 129, 130	500WV	820PF ±10%
				7, 27, 120, 121,	500WV	1000PF ±10%
				131		
				17	500WV	2200PF ±10%
				133	500WV	3000PF ±10%
				<b>MOULDED MICA</b>		
				13, 104	1KWV	80PF ±10%
				125	1KWV	100PF ±10%
				11	1KWV	200PF ±10%
				23	1.5KWV	1000PF ±10%
				<b>CERAMIC DISC</b>		
<b>RECTIFIER UNIT</b>						
<b>PRINTED CIRCUIT BOARD PB-1076(A-Z)</b>						
<b>D-DIODE</b>						
5, 6	Si.	IS1942				
1-4, 9-12	Si.	10D10				
7, 8	Si.	V06B				
<b>R-RESISTOR</b>						
<b>CARBON FILM</b>						
6-13	1/4W	470	KΩ ±10%			
<b>CARBON COMPOSITION</b>						
4, 5	1 W	3.3	KΩ ±10%			
1	2 W	5.6	KΩ ±10%			
<b>METALIC FILM</b>						
3	5W	220	Ω ±10%			
<b>C-CAPACITOR</b>						
<b>CERAMIC DISC</b>						
6	50WV	0.047	μF ±80% ±20%			
4	500WV	0.01	μF ±100% ±0%			
1, 2, 5	1.4KV	0.0047	μF ±100% ±0%			
<b>ELECTROLYTIC</b>						
3	25WV	470	μF			
<b>MAIN CHASSIS</b>						
<b>V-VACUUM TUBE</b>						
1	12BY7A					
2, 3	6JS6C					
<b>Q-TRANSISTOR</b>						
1, 2	TR.	2SB206				
3	TR.	2SC372Y				
<b>D-DIODE</b>						
4, 7	Ge.	IS1007				

# FT-101-B PARTS

51, 62, 65, 81~83, 86, 87, 90, 118	50WV 0.01 $\mu$ F $\pm \frac{80}{20}\%$	T-TRANSFORMER & CHOKE COIL	11	POWER TRANSFORMER
33, 38, 50, 52, 59~61, 66, 69~73, 85, 89, 91, 94, 95, 100, 103	50WV 0.047 $\mu$ F $\pm \frac{80}{20}\%$		12	AF CHOKE 20mH 0.5A
8, 14, 15, 20, 22	500WV 0.0047 $\mu$ F $\pm \frac{100}{0}\%$	F-FUSE	1	AC 5A(100~117V)3A(200~234V)
3, 19, 21, 101, 102	500WV 0.01 $\mu$ F $\pm \frac{100}{0}\%$		2	DC 20A
74	1.4KV 0.001 $\mu$ F $\pm \frac{100}{0}\%$	FH-FUSE HOLDER		
24	1.4KV 0.0047 $\mu$ F $\pm \frac{100}{0}\%$		1	AC S-N1001
36, 75	1.4KV 0.01 $\mu$ F $\pm \frac{100}{0}\%$		2	DC S-N1102
25	(RDA30) 3KV 150PF $\pm 10\%$	RL-RELAY		
132	3KV 600PF $\pm 10\%$		1	AE3171-42
	CERAMIC FEED THRU		2	MX2P
30~32, 34, 35, 37, 39, 40, 67, 68, 84, 110	500WV 0.001 $\mu$ F $\pm \frac{100}{0}\%$			
	PLASTIC FILM	S-SWITCH		
140, 141	50WV 0.047 $\mu$ F $\pm 20\%$		1	ROTARY RS13-13-11(BAND)
18	50WV 0.22 $\mu$ F $\pm 20\%$		2	ROTARY ESRE365R20Z(MODE)
49	50WV 0.47 $\mu$ F $\pm 20\%$		4	ROTARY ESRE246R20Z(SELECT)
	METALIZED PAPER		6	SEASAW WD3001 (POWER)
76	160WV 2.2 $\mu$ F $\pm 20\%$		5	SEASAW WD3201 (HEATER)
145	220VAC 1 $\mu$ F		3, 10	SLIDE SS-F22-08
	ELECTROLYTIC		7~9	SLIDE SS-H23-08
142, 146	16WV 1 $\mu$ F			
54, 144	16WV 10 $\mu$ F			
143	16WV 100 $\mu$ F			
63	16WV 220 $\mu$ F	X-CRYSTAL		
109	450WV 2.2 $\mu$ F		1 80M	HC-25/U 9.52MHz
77, 78	500WV 100 $\mu$ F		2 40M	HC-25/U 13.02MHz
	VC-VARIABLE CAPACITOR		3 20M	HC-25/U 20.02MHz
1	(PLATE) AIR RT18B300VC 300PF		4 15M	HC-25/U 27.02MHz
2	(LOADING)AIR C123A129		5 11M	HC-25/U 33.02MHz
	TC-TRIMMER CAPACITOR		6 10M-A	HC-25/U 34.02MHz
	CERAMIC		7 10M-B	HC-25/U 34.52MHz
5	ECVIZW10P32 10PF		8 10M-C	HC-25/U 35.02MHz
1~4, 11~25	ECVIZW50P32 50PF		9 10M-D	HC-25/U 35.52MHz
7, 8, 9	MICA B-1PY 40PF		10 JJY/WWV	HC-25/U 16.02MHz
6, 31	B-2PY 100PF		11 160M	HC-25/U 7.52MHz
10, 26, 28, 29	B-7P 420PF			
27	AIR TSN-150C 10PF			
	PLASTIC FILM	MJ-MULTI JACK		
30	CTY12B 10PF		1, 2, 6	3305-018-011 18P
	L-INDUCTOR		3, 4	3305-022-011 22P
12, 13, 16~18, 20, RF CHOKE	250 $\mu$ H		5	3305-014-011 14P
21, 26, 31, 35			7	3305-010-011 10P
3, 11, 14, 15, 36	RF CHOKE(TV-2 4 5) 250 $\mu$ H	PL-LAMP		
9	RF CHOKE 300 $\mu$ H		1, 2, 4	16V 0.15A
7	RF CHOKE(PLATE) 500 $\mu$ H		3	14V 40mA
2	RF CHOKE 1mH		5, 6	TLR-104
24	P.S. $\frac{1}{2}$ W56 $\Omega$ 0.3 $\phi$ 10TS	PLH-LAMP HOLDER		
1, 4, 37	P.S. $\frac{1}{2}$ W56 $\Omega$ 0.6 $\phi$ 4TS		1, 2	#001011
5, 6	P.S. 1W56 $\Omega$ 1.0 $\phi$ 4TS		3	B-1
8	TANK COIL	VS-TUBE SOCKET		
22	TRAP COIL		1	TS103C01
28	TRAP COIL		2, 3	S-B0703
29	TRAP COIL	J-RECEPTACLE & JACK		
32	TRAP COIL		1, 4, 5, 7, 8, 11, 16~18	CN-7017
33	TUNING COIL		2	S-G7616 (KEY)
25	L.P.FILTER COIL		10	S-G7814 (PHONE)
			3	FM-144 (MIC)
			6	JSO-239 (ANT)
			9	450AB12M(POWER)
			12	P2240 (SP)
	T-TRANSFORMER & INDUCTOR		13	S-B0611 (EXT. VFO)
101A	ANT COIL A		14	SA602B(ACC)
102	GRID COIL A		15	S-16303 (FAN)
103	DRIVER COIL A			
104	ANT COIL B			
105	DRIVER COIL B			
106	GRID COIL B			
107	5MHz TRAP COIL	M-METER		
111	OSC COIL		1	MK-45
115	3.18MHz TRAP COIL			

# FT-101-E/EE/EX PARTS

RF UNIT				17	50WV	0.047 $\mu$ F
PRINTED CIRCUIT BOARD PB-1181(A~Z)						
<b>Q FET &amp; TRANSISTOR</b>				14~16 CERAMIC FEED THRU		
4	TR.	2SC372Y			500WV	0.001 $\mu$ F
5	TR.	2SC373		18	ELECTROLYTIC	16WV 1 $\mu$ F
3	TR.	2SC784R				
2	FET	2SK19GR		<b>TC TRIMMER CAPACITOR</b>		
1	FET	3SK40M		1~3	CERAMIC	ECV1ZW50P32 50PF
<b>D DIODE</b>						
1, 2	Si.	1S1555		<b>L INDUCTOR</b>		
				1		BPF-A
				2		BPF-B
				3		BPF-C
<b>R RESISTOR</b>				34		RF CHOKE 1.95 $\mu$ H
22	CARBON FILM	$\frac{1}{4}$ W	56 $\Omega$	4, 8		RF CHOKE 250 $\mu$ H
23		$\frac{1}{4}$ W	100 $\Omega$			
16, 24		$\frac{1}{4}$ W	220 $\Omega$			
6		$\frac{1}{4}$ W	330 $\Omega$	<b>T TRANSFORMER &amp; INDUCTOR</b>		
10, 19		$\frac{1}{4}$ W	470 $\Omega$	112A		IF TRANSFORMER
11		$\frac{1}{4}$ W	560 $\Omega$	113		TRAP COIL
9, 13		$\frac{1}{4}$ W	1K $\Omega$			
7		$\frac{1}{4}$ W	1.8K $\Omega$	<b>X CRYSTAL</b>		
8		$\frac{1}{4}$ W	2.2K $\Omega$	1	HC-18/U	6360KHz
17, 20		$\frac{1}{4}$ W	3.3K $\Omega$			
21		$\frac{1}{4}$ W	8.2K $\Omega$	<b>IF UNIT</b>		
14, 18		$\frac{1}{4}$ W	15K $\Omega$	PRINTED CIRCUIT BOARD PB-1183(A~Z)		
2		$\frac{1}{4}$ W	22K $\Omega$	<b>Q FET, IC &amp; TRANSISTOR</b>		
4		$\frac{1}{4}$ W	82K $\Omega$	2	TR.	2SC784R
1, 3, 5, 12		$\frac{1}{4}$ W	100K $\Omega$	4, 5	TR.	2SC828Q
				3	IC	TA7045M
				1	FET	2SK19GR
<b>VR VARIABLE RESISTOR</b>				<b>D DIODE</b>		
1	TR-11R		5K $\Omega$ B	1~5, 7~11	Ge.	1S1007
<b>C CAPACITOR</b>				6	Si.	1S1555
17	DIPPED MICA	50WV	6PF	12	Zener	WZ-110
5		50WV	50PF	<b>R RESISTOR</b>		
1, 11		50WV	100PF	2, 13, 16	CARBON FILM	$\frac{1}{4}$ W 100 $\Omega$
3	CERAMIC DISC	50WV	0.001 $\mu$ F	23		$\frac{1}{4}$ W 220 $\Omega$
2, 4, 7~10, 12~16,		50WV	0.01 $\mu$ F	28		$\frac{1}{4}$ W 330 $\Omega$
6, 18		50WV	0.047 $\mu$ F	20		$\frac{1}{4}$ W 470 $\Omega$
19	ELECTROLYTIC	16WV	47 $\mu$ F	12, 15, 19		$\frac{1}{4}$ W 1K $\Omega$
<b>L INDUCTOR</b>				3, 14		$\frac{1}{4}$ W 2.2K $\Omega$
1, 2	RF CHOKE		1mH	22		$\frac{1}{4}$ W 2.7K $\Omega$
3	RF CHOKE		250 $\mu$ H	8, 9		$\frac{1}{4}$ W 3.3K $\Omega$
<b>MIXER UNIT</b>				11		$\frac{1}{4}$ W 3.9K $\Omega$
PRINTED CIRCUIT BOARD PB-1082(A~Z)				4, 5		$\frac{1}{4}$ W 5.6K $\Omega$
PB-1180(A~Z)				17, 24, 25, 27		$\frac{1}{4}$ W 10K $\Omega$
<b>Q FET &amp; TRANSISTOR</b>				10		$\frac{1}{4}$ W 27K $\Omega$
1	TR.	2SC372Y		1, 18, 21, 26		$\frac{1}{4}$ W 100K $\Omega$
2	FET	3SK40M		6, 7	CARBON COMPOSITION	$\frac{1}{2}$ W 100 $\Omega$
<b>D DIODE</b>				<b>VR VARIABLE RESISTOR</b>		
1	Si.	1S1555		1	TR12R	500 $\Omega$ B
<b>R RESISTOR</b>				2	TR11R	500 $\Omega$ B
12	CARBON FILM	$\frac{1}{4}$ W	10 $\Omega$	<b>C CAPACITOR</b>		
5, 7		$\frac{1}{4}$ W	100 $\Omega$	1, 24, 25	DIPPED MICA	50WV 100PF
13		$\frac{1}{4}$ W	470 $\Omega$	15, 22		50WV 150PF
3, 16, 17		$\frac{1}{4}$ W	1K $\Omega$	11, 17		50WV 470PF
2		$\frac{1}{4}$ W	4.7K $\Omega$	26~28	CERAMIC DISC	50WV 0.001 $\mu$ F
14, 15		$\frac{1}{4}$ W	5.6K $\Omega$	2~6, 9, 10, 12, 13, 18, 20,		50WV 0.01 $\mu$ F
10		$\frac{1}{4}$ W	10K $\Omega$	21, 23, 31~34		
4, 6		$\frac{1}{4}$ W	15K $\Omega$	7, 8, 14, 16, 19, 35		50WV 0.047 $\mu$ F
11		$\frac{1}{4}$ W	22K $\Omega$	29	PLASTIC FILM	50WV 0.47 $\mu$ F
1		$\frac{1}{4}$ W	27K $\Omega$	30	ELECTROLYTIC	16WV 10 $\mu$ F
8		$\frac{1}{4}$ W	100K $\Omega$	<b>L INDUCTOR</b>		
9		$\frac{1}{4}$ W	220K $\Omega$	1~4	RF CHOKE	250 $\mu$ H
<b>C CAPACITOR</b>				<b>T TRANSFORMER &amp; INDUCTOR</b>		
6, 19	DIPPED MIBA	50WV	20PF	108		IF TRANSFORMER
1		50WV	40PF	109		IF TRANSFORMER(DETECTOR)
8		50WV	150PF	<b>XF CRYSTAL FILTER</b>		
2		50WV	470PF			
7	CERAMIC DISC	50WV	0.001 $\mu$ F			

# FT-101-E/EE/EX/PARIS

1	XF-32A SSB	R	RESISTOR		
2	XF-30C CW(OPTION)	18	CARBON FILM 1/4 W		100 Ω
		1, 3	1/4 W		150 Ω
		19	1/4 W		180 Ω
<b>AF UNIT</b>					
PRINTED CIRCUIT BOARD PB1315(A~Z)					
Q	FET, IC & TRANSISTOR	2, 21, 30	1/4 W		470 Ω
2, 3	TR. 2SC372Y	9~11, 14, 24, 28	1/4 W		1KΩ
6, 7	TR. 2SC373	20	1/4 W		1.5KΩ
9	TR. 2SC1000GR	6, 8	1/4 W		2.2KΩ
1	FET. 2SK19GR	12, 15, 16, 22, 25, 26, 29	1/4 W		4.7KΩ
5	FET. 2SK19Y	32	1/4 W		10KΩ
8	IC AN214	33	1/4 W		15KΩ
4	IC TA-7042M	13, 17, 23, 27	1/4 W		22KΩ
		7	1/4 W		33KΩ
		4	1/4 W		100KΩ
D	DIODE				
1, 2, 3, 4	1S1555	VR	VARIABLE RESISTOR		
5	WZ-090	1	TR11R		500 ΩB
		2	TR11R		5KΩB
R	RESISTOR	C	CAPACITOR		
13, 14	CARBON FILM 1/4 W	20, 28, 30	DIPPED MICA 50WV		30PF
53	1/4 W	19, 27, 32	50WV		40PF
41	1/4 W	38	50WV		50PF
12	1/4 W	37	50WV		82PF
16, 17, 33	1/4 W	5, 10,	50WV		100PF
45	1/4 W	4	50WV		150PF
27	1/4 W	21	50WV		300PF
5, 8, 15, 45, 49	1/4 W	23	50WV		820PF
21	1/4 W	36	50WV		1000PF
20, 28, 34	1/4 W	31	CERAMIC DISC 50WV		0.001μF
6	1/4 W	2, 8, 9, 13, 17, 18, 24,	50WV		0.01μF
1, 3, 14, 29~31, 38, 39, 40	1/4 W	26, 29, 33			
4, 48	1/4 W	6, 11, 22, 25, 34	50WV		0.047μF
9, 10, 35	1/4 W	12	PLASTIC FILM 50WV		0.22μF
51,	1/4 W	15	ELECTROLYTIC 16WV		100μF
11, 18	1/4 W	TC	TRIMMER CAPACITOR		
7, 52	1/4 W	2~4	CERAMIC ECV1ZW20P40		20PF
43, 47	1/4 W	1, 5, 6	ECV1ZW50P40		50PF
32, 42	1/4 W				
50	1/4 W	L	INDUCTOR		
2, 36, 37, 46	1/4 W	5	RF CHOKE		10μH
22	1/4 W	2~4, 6, 7	RF CHOKE		22μH
23, 24	1/2 W	8, 9	RF CHOKE		250μH
25,	1/2 W				
26	THERMISTOR SDT250	T	TRANSFORMER		
		110	IF TRANSFORMER		
VR	VARIABLE RESISTOR	X	CRYSTAL		
3, 4	TR-11R 10KΩB	1	HC-6/U 3178.5 kHz(USB)		
1, 5	V160KRZ-1 10KΩB	2	HC-6/U 3181.5 kHz(LSB)		
2	V160KRZ-1 2MΩB	3	HC-6/U 3179.3 kHz(CW/AM)		
C	CAPACITOR	<b>REG &amp; CALIB UNIT</b>			
46	DIPPED MICA 50WV	PRINTED CIRCUIT BOARD PB-1314(A~Z)			
15, 27, 51, 52	MYLAR 50WV	Q	TRANSISTOR & IC		
47	50WV	1, 3	TR. 2SC735Y		
1, 9, 12, 17, 22, 33, 34	50WV	2	IC MFC-6020		
24, 28, 29, 30,	50WV	4	IC MFC-6030A~4A		
3, 25, 26, 39, 48, 50	50WV				
23, 32, 37, 43, 45	50WV	D	DIODE		
5, 6, 7, 10, 14, 21	ELECTROLYTIC 16WV	1, 2, 3	Si 1S1555		
11	16WV				
2, 16, 19, 20, 31, 36	16WV	R	RESISTOR		
8, 35	16WV	3, 6	CARBON FILM 1/4 W		100 Ω
40	16WV	10, 19, 20	1/4 W		470 Ω
4, 18, 38, 42, 49	16WV	8	1/4 W		560 Ω
13, 41, 44	16WV	7, 21	1/4 W		680 Ω
		16	1/4 W		1.5KΩ
		17	1/4 W		4.7KΩ
		1, 4, 13, 15, 18	1/4 W		10KΩ
		2	1/4 W		15KΩ
		14	1/4 W		47KΩ
		2, 5	1/4 W		100KΩ
		9	CARBON COMPOSITION 1/2 W		4.7 Ω
		11	2W		6.8KΩ
<b>MOD &amp; OSC UNIT</b>					
PRINTED CIRCUIT BOARD PB-1184(A~Z)					
Q	FET & TRANSISTOR				
2, 3, 5, 6	TR. 2SC372Y				
4	TR. 2SC828P				
1	FET. 2SK19Y				
D	DIODE				
1~4	Ge. 1S1007				

<b>VR</b>	<b>VARIABLE RESISTOR</b>			<b>T</b>	<b>TRANSFORMER</b>		
4	TR11R	500ΩB		116~119	IF TRANSFORMER R12-4129		
3	TR11R	1KΩB					
2	V160KRZ-1	10KΩB					
					<b>FIX RF PROCESS UNIT</b>		
					PRINTED CIRCUIT BOARD PB-1534		
<b>C</b>	<b>CAPACITOR</b>			<b>Q</b>	<b>IC, FET &amp; TRANSISTOR</b>		
7~9	DIPPED MICA	50WV	30PF	2	IC	TA7060P	
5, 10		50WV	40PF	1, 3, 4, 6, 7	FET	2SK19GR	
1		50WV	100PF	5	TR	2SC372Y	
2		50WV	250PF				
3		50WV	2000PF	<b>D</b>	<b>DIODE</b>		
4, 6	CERAMIC DISC	50WV	0.01μF	1	Si	1S1555	
17	PLASTIC FILM	50WV	0.001μF	2	Varactor	1S2236	
15		50WV	0.1μF				
20		250WV	0.047μF	<b>XF</b>	<b>CRYSTAL FILTER</b>		
13, 14	DLECTROLYTIC	16WV	1000μF	1	XF-30A		
16		16WV	100μF				
11, 12		25WV	1000μF	<b>XS</b>	<b>CRYSTAL SOCKET</b>		
21		150WV	22μF	1	S-14	2P	
18, 19, 22		250WV	22μF				
				<b>R</b>	<b>RESISTOR</b>		
<b>TC</b>	<b>TRIMMER CAPACITOR</b>			23	CARBON FILM	¼W	56Ω
1	CERAMIC	ECV1ZW50P40	50PF	2, 3, 5, 10, 15, 20, 24	¼W		100Ω
				11	¼W		470Ω
<b>L</b>	<b>INDUCTOR</b>			7, 9	¼W		1KΩ
1, 2	RF CHOKE		4mH	6, 16, 19	¼W		2.2KΩ
				1, 4	¼W		3.3KΩ
<b>X</b>	<b>CRYSTAL</b>			8, 12, 14, 17	¼W		10KΩ
1	HC-13/U		100 kHz	13, 18, 21, 22	¼W		100KΩ
	<b>NB UNIT</b>			<b>VR</b>	<b>POTENTIOMETER</b>		
	PRINTED CIRCUIT BOARD PB-1292(A~Z)			1	V10K8-1-2		500B
<b>Q</b>	<b>FET &amp; TRANSISTOR</b>			2	V10K8-1-2		5KB
1, 6	TR.	2SC372Y					
4	TR.	2SC784R		<b>C</b>	<b>CAPACITOR</b>		
2, 3, 5	FET	2SK19GR		26	DIPPED MICA	50WV	20PF
				29		50WV	51PF
<b>D</b>	<b>DIODE</b>			4	CERAMIC DICS	50WV	20PF(CH)
1~3	Si	1S1555		19		50WV	27PF(CH)
4	Zener	WZ090		9, 15		50WV	100PF(CH)
				1~3, 5~8, 10~14		50WV	0.01μF
<b>R</b>	<b>RESISTOR</b>			16~18, 20, 22~25, 27, 28			
4, 13	CARBON FILM	¼W	100Ω	21		50WV	0.047μF
16		¼W	330Ω				
3		¼W	560Ω	<b>TC</b>	<b>TRIMMER CAPACITOR</b>		
6, 8, 12, 19		¼W	1KΩ	1, 2	ECV-1ZW20P32		20PF
18		¼W	1.5KΩ				
15		¼W	2.2KΩ	<b>T</b>	<b>TRANSFORMER</b>		
9, 11, 21, 22		¼W	3.3KΩ	1~3	R 12-4424		
1		¼W	4.7KΩ				
23		¼W	15KΩ	<b>L</b>	<b>INDUCTOR</b>		
2, 10		¼W	22KΩ	1	RFC		250μH
5, 7, 14, 17, 20		¼W	100KΩ	2	RFC		270μH
				3	FIX OUT		#00054
<b>VR</b>	<b>VARIABLE RESISTOR</b>						
1	TR11R		10KΩB				
					<b>VFO UNIT</b>		
					PRINTED CIRCUIT BOARD PB-1056(A~Z)		
<b>C</b>	<b>CAPACITOR</b>			<b>Q</b>	<b>FET &amp; TRANSISTOR</b>		
1		50WV	3PF	3	TR.	2SC372Y	
13		50WV	6PF	1, 2	FET	2SK19GR	
3, 9, 16, 18		50WV	30PF				
12		50WV	50PF	<b>D</b>	<b>DIODE</b>		
11, 21, 22		50WV	100PF	1	Varactor	1S2236	
2, 4, 8, 15		50WV	130PF				
5, 10, CERAMIC DISC		50WV	0.01μF	<b>R</b>	<b>RESISTOR</b>		
14, 17, 19, 20, 24, 25, 28, 29				4, 7	CARBON FILM	¼W	100Ω
6, 26, 27		50WV	0.047μF	10		¼W	270Ω
7, 23	ELECTROLYTIC	16WV	1μF	3, 6		¼W	330Ω
				8		¼W	8.2KΩ
<b>TC</b>	<b>TRIMMER CAPACITOR</b>			1		¼W	10KΩ
1~4	CERAMIC	ECV1ZW50P40	50PF	9		¼W	22KΩ
				2, 5		¼W	100KΩ
<b>L</b>	<b>INDUCTOR</b>			11(L5)	CARBON COMPOSITION	½W	1KΩ
2	RF CHOKE		250μH				
1, 3~5	RF CHOKE		1mH	<b>C</b>	<b>CAPACITOR</b>		

16	DIPPED MICA	50WV	20PF	6, 67	1/2 W	2.2KΩ
8, 10		50WV	100PF	2	1/2 W	3.3KΩ
1, 2		50WV	650PF	44	1/2 W	4.7KΩ
11*		50WV	1000PF	19, 20	1/2 W	5.6KΩ
11		50WV	2000PF	8	1/2 W	10KΩ
6, 7, 9, 12, 15	CERAMIC DISC	50WV	0.01μF	36, 56	1/2 W	33KΩ
3, 5, 13		500WV	0.01μF	3	1/2 W	47KΩ
14	CERAMIC TC	NP0	6PF	28, 29	1/2 W	470KΩ
4		NP0	10PF	13	1/2 W	1MΩ
19		NP0	82PF	10, 11	1W	56Ω
20		N750	2PF	30	METALIC FILM	1W 47KΩ
18		N750	7PF	5	3W	5.1KΩ
17		N750	20PF	40	5W	1.5KΩ
				37	5W	18KΩ
<b>VC</b>	<b>VARIABLE CAPACITOR</b>			12	WIRE WOUND	METER SHUNT
1	AIR	B521A112				
				<b>VR</b>	<b>VARIABLE RESISTOR</b>	
<b>TC</b>	<b>TRIMMER CAPACITOR</b>			3	EVKA2A10306	1KΩB/10KΩB
1	AIR	TSN150C30PF		6	EVHBOAS15B13	1KΩB
2	AIR	TSN150C10PF×2		1	EVKA2AF02314	5KΩA/1KΩB
				2	EVKA2AF01339	5KΩA/5KΩB
<b>L</b>	<b>INDUCTOR</b>			4	TR-11R	500ΩB
1	OSCILLATOR COIL					
2~4, 6, 7	RF CHOKE		250μH	<b>C</b>	<b>CAPACITOR</b>	
5(R11)	RF CHOKE			123	DIPPED MICA	500WV 2PF
				134		500WV 3PF
				28		500WV 5PF
				1, 16, 98, 107		500WV 10PF
				44		500WV 20PF
				97, 106, 122		500WV 30PF
				5, 6, 10, 42, 43, 47		500WV 50PF
				135		500WV 60PF
				48, 53, 55, 92, 99		500WV 100PF
				46, 111		500WV 150PF
				29		500WV 200PF
				4, 9, 127		500WV 250PF
				41		500WV 270PF
				45		500WV 300PF
				105, 108		500WV 400PF
				2, 26, 136		500WV 470PF
				128, 129, 130		500WV 820PF
				7, 27, 120, 121, 131		500WV 1000PF
				17		500WV 2200PF
				133		500WV 3000PF
				13, 104	MOULDED MICA	1KVV 80PF
				125		1KVV 100PF
				11		1KVV 200PF
				23		1.5KVV 1000PF
				51, 62, CERAMIC DISC	50WV	0.01μF
				65, 81~83, 86, 87, 90, 118		
				33, 38, 50, 52, 59~61, 66,	50WV	0.047μF
				69~73, 85, 89, 91, 94, 95,		
				100, 103		
				8, 14, 15, 20, 22	500WV	0.0047μF
				3, 19, 21, 101, 102	500WV	0.01μF
				74	1.4KV	0.001μF
				24	1.4KV	0.0047μF
				36, 75	1.4KV	0.01μF
				25	(RDA30) 3KV	150PF
				132	3KV	600PF
				30~32, CERAMIC FEED		
				34, 35, 37, 39, 40, 67,	500WV	0.001μF
				68, 84, 110		
				18	PLASTIC FILM	50WV 0.22μF
				49		50WV 0.47μF
				150	METALIZED PAPER	160WV 0.47μF
				146	ELECTROLYTIC	16WV 1μF
				54, 144	16WV	10μF
				63	16WV	220μF
				109	450WV	2.2μF
				77, 78	500WV	100μF
				<b>VC</b>	<b>VARIABLE CAPACITOR</b>	
				1	(PLATE)AIR	RT18B30VC 300PF
				2	(LOADING)AIR	C123A129



# FT-101-E/EE/EX PARTS

TC TRIMMER CAPACITOR				MJ MULTI JACK		
5	CERAMIC	ECV1ZW10P32	10PF	1, 2, 6	3305-018-011	18P
1~4, 11~25		ECV1ZW50P32	50PF	3, 4	3305-022-011	22P
7, 8, 9	MICA	B-1PY	40PF	5	3305-014-011	14P
6, 31		B-2PY	100PF	7	3305-010-011	10P
10, 26, 28, 29		B-7P	420PF			
27	AIR	TSN-150C	10PF	<b>PL LAMP</b>		
30	PLASTIC FILM	CTY12B	10PF	1, 2, 4	16V 0.15A	
				3	14V 40mA	
				5, 6	LED	TLR-104
<b>L INDUCTOR</b>				<b>PLH LAMP HOLDER</b>		
12, 13, 16~18, 20, 21, 26, 31, 35	RF CHOKE		250 $\mu$ H	1, 2	#001011	
3, 11, 36	RF CHOKE(TV-245)		250 $\mu$ H	3	B-1	
9	RF CHOKE(PLATE)		300 $\mu$ H			
7	RF CHOKE(PLATE)		500 $\mu$ H			
2	RF CHOKE		1mH	<b>J RECEPTACLE &amp; JACK</b>		
24	P.S. $\frac{1}{2}$ W56 $\Omega$ 0.3 $\phi$ 10TS			1, 4, 5, 7, 8, 11, 16~18	CN-7017	
1, 4, 37	P.S. $\frac{1}{2}$ W56 $\Omega$ 0.6 $\phi$ 4TS			2	S-G7616(KEY)	
5, 6	P.S. 1W56 $\Omega$ 1.0 $\phi$ 4TS			10	S-G7814(PHONE)	
8	TANK COIL			3	FM-144(MIC)	
22	TRAP COIL			6	JSO-239(ANT)	
28	TRAP COIL			9	450AB12M(POWER)	
29	TRAP COIL			12	P2240(SP)	
32	TRAP COIL			13	S-B0611(EXT. VFO)	
33	TUNING COIL			14	SA602B(ACC)	
25	L. P. FILTER COIL			15	S-I6303(FAN)	
14, 15	RF CHOKE		35 $\mu$ H			
<b>T TRANSFORMER &amp; INDUCTOR</b>				<b>M METER</b>		
101A	ANT COIL A			1	MK-45	
102	GRID COIL A					
103	DRIVER COIL A					
104	ANT COIL B					
105	DRIVER COIL B					
106	GRID COIL B					
107	5MHz TRAP COIL					
111	OSC COIL					
115	3.18MHz TRAP COIL					
<b>T TRANSFORMER &amp; CHOKE COIL</b>						
11	ROWER TRANSFORMER					
12	AF CHOKE 20m H 0.5A					
<b>F FUSE</b>						
1	AC 5A(100~117V)3A(200~234V)					
2	DC 20A					
<b>FH FUSE HOLDER</b>				For Service Manuals Contact <b>MAURITRON TECHNICAL SERVICES</b> 8 Cherry Tree Rd, Chinnor Oxon OX9 4QY Tel: 01844 351694 Fax: 01844 352554 Email: enquiries@mauratron.co.uk		
1	AC S-N1001					
2	DC S-N1102					
<b>PL RELAY</b>						
1	AE3171-42					
2	MX2P					
<b>S SWITCH</b>						
1	ROTARY RS13-13-11(BAND)					
2	ROTARY ESRE365R20Z(MODE)					
4	ROTARY ESRE246R20Z(SELECT)					
6	SEESAW WD2101(POWER)					
5	SEESAW WD2301(HEATER)					
3, 10, 11	SLIDE SLE12201					
7~9	SLIDE SLE12301					
<b>X CRYSTAL</b>						
1	80M	HC-25/U	9.52MHz			
2	40M	HC-25/U	13.02MHz			
3	20M	HC-25/U	20.02MHz			
4	15M	HC-25/U	27.02MHz			
5	11M	HC-25/U	33.02MHz			
6	10M-A	HC-25/U	34.02MHz			
7	10M-B	HC-25/U	34.52MHz			
8	10M-C	HC-25/U	35.02MHz			
9	10M-D	HC-25/U	35.52MHz			
10	JJY/WWV	HC-25/U	16.02MHz			
11	160M	HC-25/U	7.52MHz			

## ACKNOWLEDGEMENTS

We wish to thank Loretta Watkins, both for the typing and all of those endless "reworking" projects that production of a 226 page manual entails, artist Michael McCall for his excellent sketches and artwork depictions, Mitsu and Tokio, for their contributions and reviews, and Glenn Malme whose sage advice on publishing matters was invaluable.

A special thanks goes to Mr. Yukio Tamura, President of Yaesu Electronics Corporation who provided the opportunity, space and motivation to see the project through to a successful conclusion. His cheerful encouragement kept me from pulling my hair out by the roots at numerous stages of the manual's development.

**Fractions of an Inch with Metric Equivalents**

FRACTIONS OF AN INCH			DECIMALS OF AN INCH			MILLIMETERS		
1/32	1/64	0.0156	0.397	17/32	33/64	0.5156	13.097	
	3/64	0.0313	0.794		35/64	0.5313	13.494	
1/16		0.0469	1.191	9/16		0.5469	13.891	
	5/64	0.0625	1.588		37/64	0.5625	14.288	
3/32		0.0781	1.984	19/32		0.5781	14.684	
	7/64	0.0938	2.381		39/64	0.5938	15.081	
1/8		0.1094	2.778	5/8		0.6094	15.478	
	9/64	0.1250	3.175		41/64	0.6250	15.875	
5/32		0.1406	3.572	21/32		0.6406	16.272	
	11/64	0.1563	3.969		43/64	0.6563	16.669	
3/16		0.1719	4.366	11/16		0.6719	17.066	
	13/64	0.1875	4.763		45/64	0.6875	17.463	
7/32		0.2031	5.159	23/32		0.7031	17.859	
	15/64	0.2188	5.556		47/64	0.7188	18.256	
1/4		0.2344	5.953	3/4		0.7344	18.653	
	17/64	0.2500	6.350		49/64	0.7500	19.050	
9/32		0.2656	6.747	25/32		0.7656	19.447	
	19/64	0.2813	7.144		51/64	0.7813	19.844	
5/16		0.2969	7.541	13/16		0.7969	20.241	
	21/64	0.3125	7.938		53/64	0.8125	20.638	
11/32		0.3281	8.334	27/32		0.8281	21.034	
	23/64	0.3438	8.731		55/64	0.8438	21.431	
3/8		0.3594	9.128	7/8		0.8594	21.828	
	25/64	0.3750	9.525		57/64	0.8750	22.225	
13/32		0.3906	9.922	29/32		0.8906	22.622	
	27/64	0.4063	10.319		59/64	0.9063	23.019	
7/16		0.4219	10.716	15/16		0.9219	23.416	
	29/64	0.4375	11.113		61/64	0.9375	23.813	
15/32		0.4531	11.509	31/32		0.9531	24.209	
	31/64	0.4688	11.906		63/64	0.9688	24.606	
1/2		0.4844	12.303			0.9844	25.003	
		0.5000	12.700			1.0000	25.400	

Table reproduced by permission of The American Radio Relay League.

For Service Manuals Contact  
**MAURITRON TECHNICAL SERVICES**  
 8 Cherry Tree Rd, Chinnor  
 Oxon OX9 4QY  
 Tel:- 01844-351694 Fax:- 01844-352554  
 Email:- enquiries@mauritron.co.uk

**Conversion— Decimal feet to inches (nearest 16th)**

	0	1	2	3	4	5	6	7	8	9
0.0	0-0	0-1/8	0-1/4	0-3/8	0-1/2	0-5/8	0-3/4	0-13/16	0-15/16	1-1/16
0.1	1-3/16	1-5/16	1-7/16	1-9/16	1-11/16	1-13/16	1-15/16	2-1/16	2-3/16	2-1/4
0.2	2-3/8	2-1/2	2-5/8	2-3/4	2-7/8	3-0	3-1/8	3-1/4	3-3/8	3-1/2
0.3	3-5/8	3-3/4	3-13/16	3-15/16	4-1/16	4-3/16	4-5/16	4-7/16	4-9/16	4-11/16
0.4	4-13/16	4-15/16	5-1/16	5-3/16	5-1/4	5-3/8	5-1/2	5-5/8	5-3/4	5-7/8
0.5	6-0	6-1/8	6-1/4	6-3/8	6-1/2	6-5/8	6-3/4	6-13/16	6-15/16	7-1/16
0.6	7-3/16	7-5/16	7-7/16	7-9/16	7-13/16	7-11/16	7-15/16	8-3/16	8-1/16	8-1/4
0.7	8-3/8	8-1/2	8-5/8	8-3/4	8-7/8	9-0	9-1/8	9-1/4	9-3/8	9-1/2
0.8	9-5/8	9-3/4	9-13/16	9-15/16	10-1/16	10-3/16	10-5/16	10-7/16	10-9/16	10-11/16
0.9	10-13/16	10-15/16	11-1/16	11-3/16	11-1/4	11-3/8	11-1/2	11-5/8	11-3/4	11-7/8

**Conversion – Inches and fractions to decimal feet**

	0	1/8	1/4	3/8	1/2	5/8	3/4	7/8
0	000	010	021	031	042	052	063	073
1	083	094	104	115	125	135	146	156
2	167	177	188	198	208	219	229	240
3	250	260	271	281	292	302	313	323
4	333	344	354	365	375	385	396	406
5	417	427	438	448	458	469	479	490
6	500	510	521	531	542	552	563	573
7	583	594	604	615	625	635	646	656
8	667	677	688	698	708	719	729	740
9	750	760	771	781	792	802	813	823
10	833	844	854	865	875	885	896	906
11	917	927	938	948	958	969	979	990

**Numbered Drill Sizes**

NUM.	DIAMETER (MILS)	WILL CLEAR SCREW	DRILLED FOR TAPPING FROM STEEL OR BRASS*	NUM.	DIAMETER (MILS)	WILL CLEAR SCREW	DRILLED FOR TAPPING FROM STEEL OR BRASS*
1	228.0	—	—	27	144.0	—	—
2	221.0	12-24	—	28	140.0	6-32	—
3	213.0	—	14-24	29	136.0	—	8-32
4	209.0	12-20	—	30	128.5	—	—
5	205.0	—	—	31	120.0	—	—
6	204.0	—	—	32	116.0	—	—
7	201.0	—	—	33	113.0	4-40	—
8	199.0	—	—	34	111.0	—	—
9	196.0	—	—	35	110.0	—	6-32
10	193.5	10-32	—	36	106.5	—	—
11	191.0	10-24	—	37	104.0	—	—
12	189.0	—	—	38	101.5	—	—
13	185.0	—	—	39	99.5	3-48	—
14	182.0	—	—	40	98.0	—	—
15	180.0	—	—	41	96.0	—	—
16	177.0	—	12-24	42	93.5	—	4-40
17	173.0	—	—	43	89.0	2-56	—
18	169.5	8-32	—	44	86.0	—	—
19	166.0	—	12-20	45	82.0	—	3-48
20	161.0	—	—	46	81.0	—	—
21	159.0	—	10-32	47	78.5	—	—
22	157.0	—	—	48	76.0	—	—
23	154.0	—	—	49	73.0	—	2-56
24	152.0	—	—	50	70.0	—	—
25	149.5	—	10-24	51	67.0	—	—
26	147.0	—	—	52	63.5	—	—
				53	59.5	—	—
				54	55.0	—	—

\*Use one size larger for tapping bakelite and phenolics.

Tables reproduced courtesy of The American Radio Relay League.

**Standard Metal Gauges**

GAUGE NO.	AMERICAN OR B & S <sup>1</sup>	U.S. STANDARD	BIRMINGHAM OR STUBS <sup>3</sup>
1	.2893	.28125	.300
2	.2576	.265625	.284
3	.2294	.25	.259
4	.2043	.234375	.238
5	.1819	.21875	.220
6	.1620	.203125	.203
7	.1443	.1875	.180
8	.1285	.171875	.165
9	.1144	.15625	.148
10	.1019	.140625	.134
11	.09074	.125	.120
12	.08081	.109375	.109
13	.07196	.09375	.095
14	.06408	.078125	.083
15	.05707	.0703125	.072
16	.05082	.0625	.065
17	.04526	.05625	.058
18	.04030	.05	.049
19	.03589	.04375	.042
20	.03196	.0375	.035
21	.02846	.034375	.032
22	.02535	.03125	.028
23	.02257	.028125	.025
24	.02010	.025	.022
25	.01790	.021875	.020
26	.01594	.01875	.018
27	.01420	.0171875	.016
28	.01264	.015625	.014
29	.01126	.0140625	.013
30	.01003	.0125	.012
31	.008928	.0109375	.010
32	.007950	.01015625	.009
33	.007080	.009375	.008
34	.006350	.00859375	.007
35	.005615	.0078125	.005
36	.005000	.00703125	.004
37	.004453	.006640625	—
38	.003965	.00625	—
39	.003531	—	—
40	.003145	—	—

<sup>1</sup> Used for aluminum, copper, brass and non-ferrous alloy sheets, wire and rods.

<sup>2</sup> Used for iron, steel, nickel and ferrous alloy sheets, wire and rods.

<sup>3</sup> Used for seamless tubes; also by some manufacturers for copper and brass.

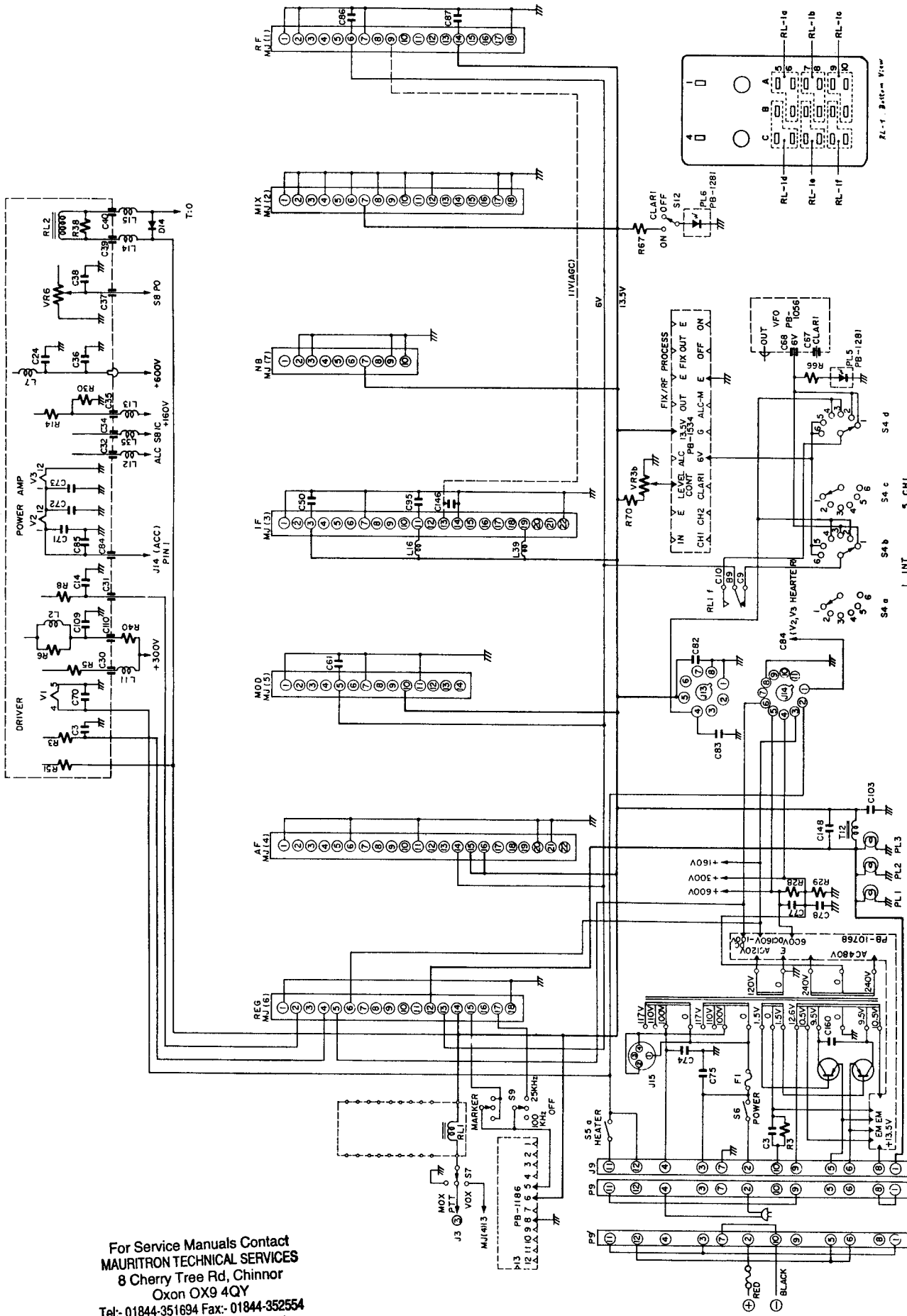

MAIN CHASSIS:  
POWER DISTRIBUTION

For Service Manuals Contact  
MAURITRON TECHNICAL SERVICES  
8 Cherry Tree Rd, Chinnor  
Oxon OX9 4QY  
Tel:- 01844-351694 Fax:- 01844-352554  
Email:- enquiries@mauritron.co.uk

THE QUALITY OF  
THIS PAGE IS  
THE BEST THAT  
IS AVAILABLE

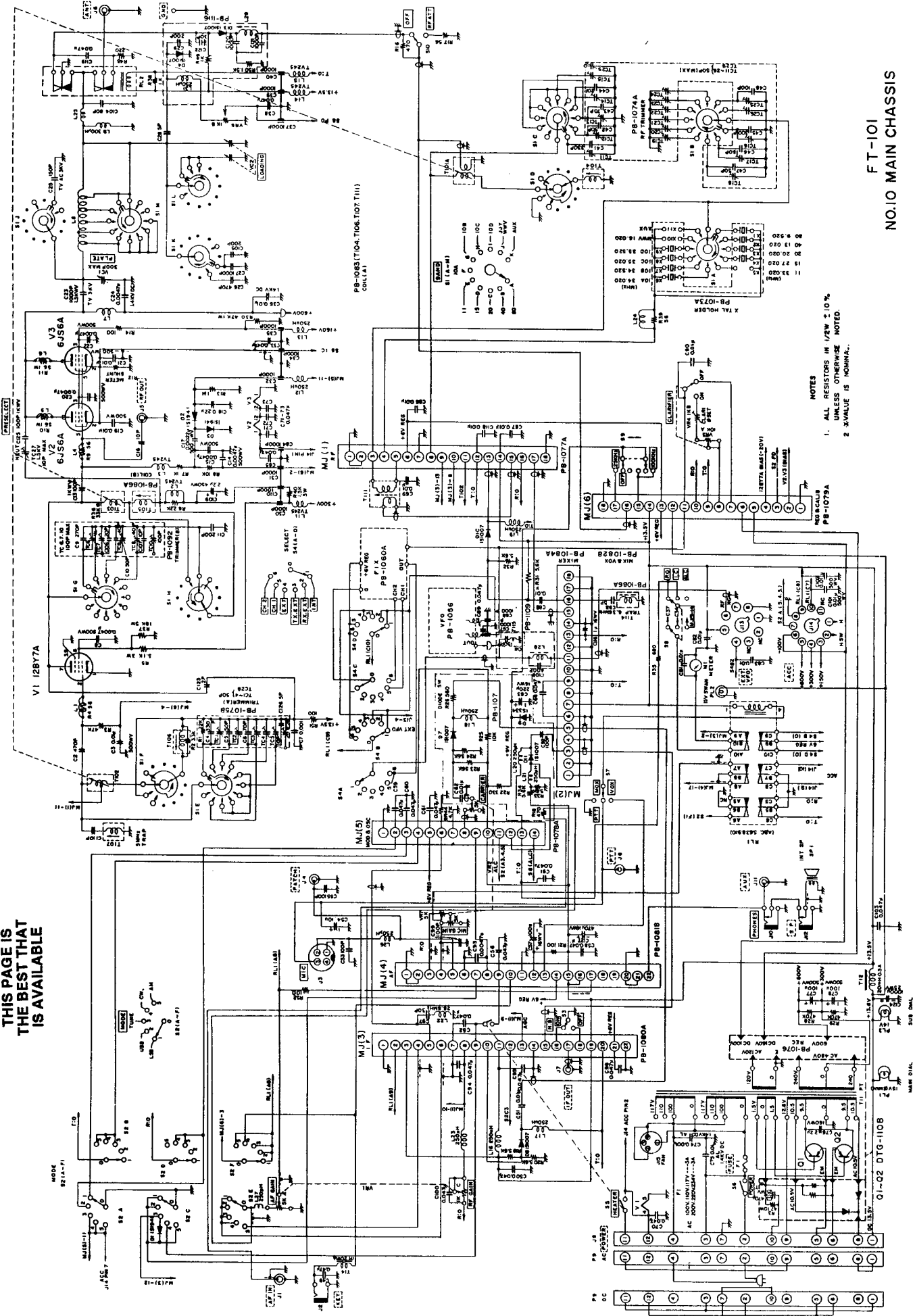

NOTES  
1. ALL RESISTORS IN 1/2W 5% UNLESS OTHERWISE NOTED.  
2. X-VALUE IS NOMINAL.

FT-101  
NO.10 MAIN CHASSIS

01-02 DTG-110B

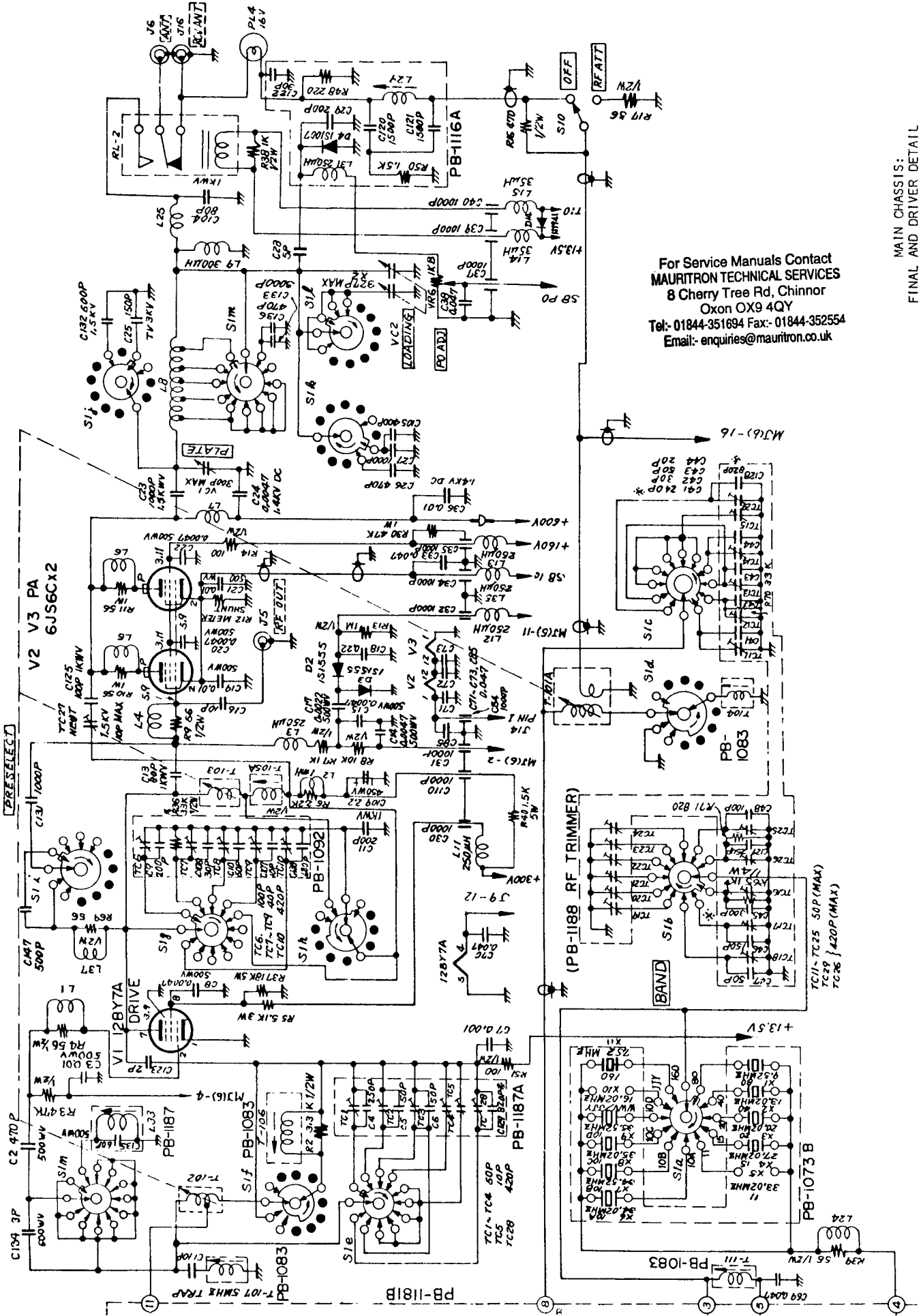

For Service Manuals Contact  
**MAURITRON TECHNICAL SERVICES**  
 8 Cherry Tree Rd, Chinnor  
 Oxon OX9 4QY  
 Tel: 01844-351694 Fax: 01844-352554  
 Email: enquiries@mauritron.co.uk

MAIN CHASSIS:  
 FINAL AND DRIVER DETAIL

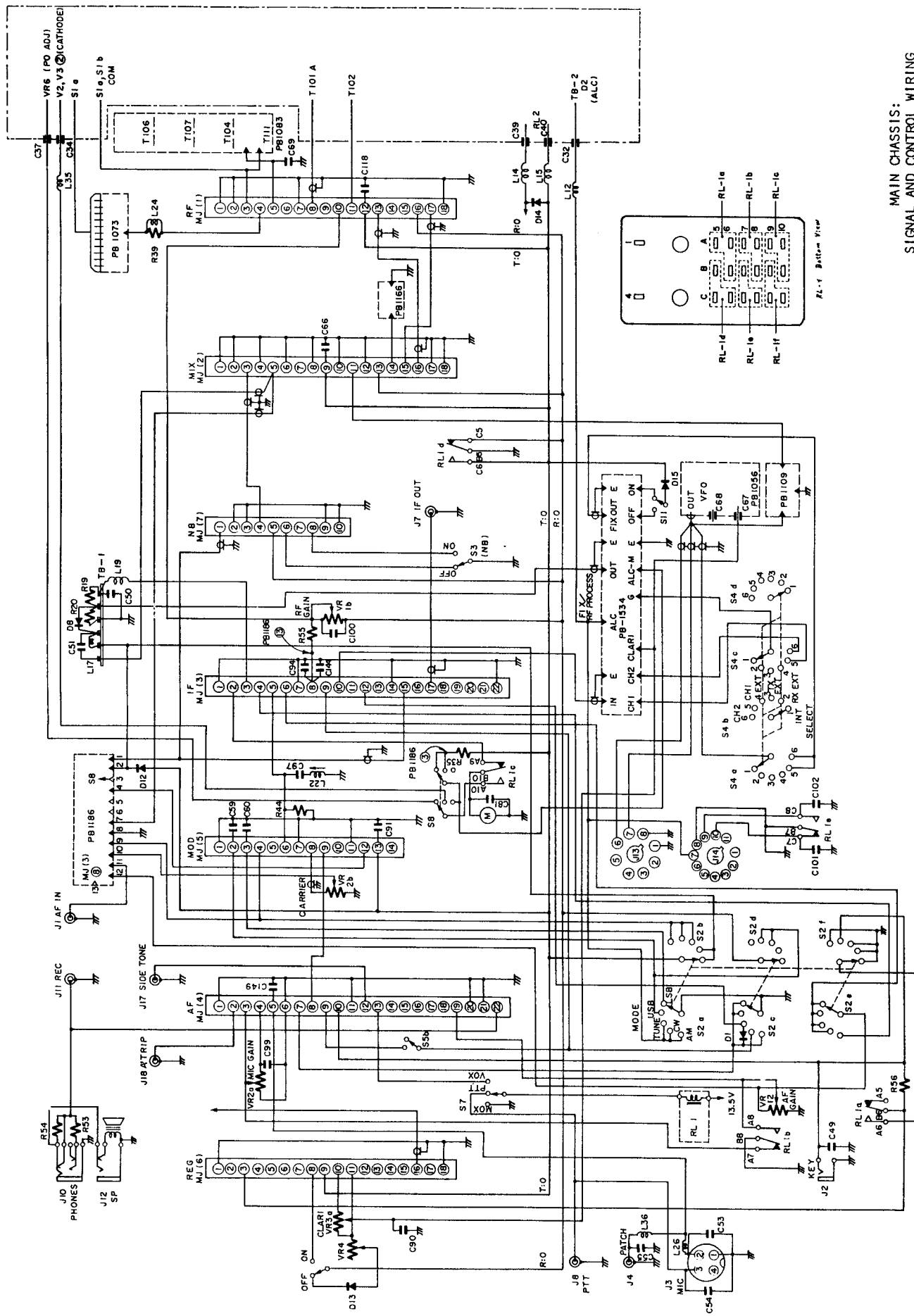

MAIN CHASSIS:  
SIGNAL AND CONTROL WIRING



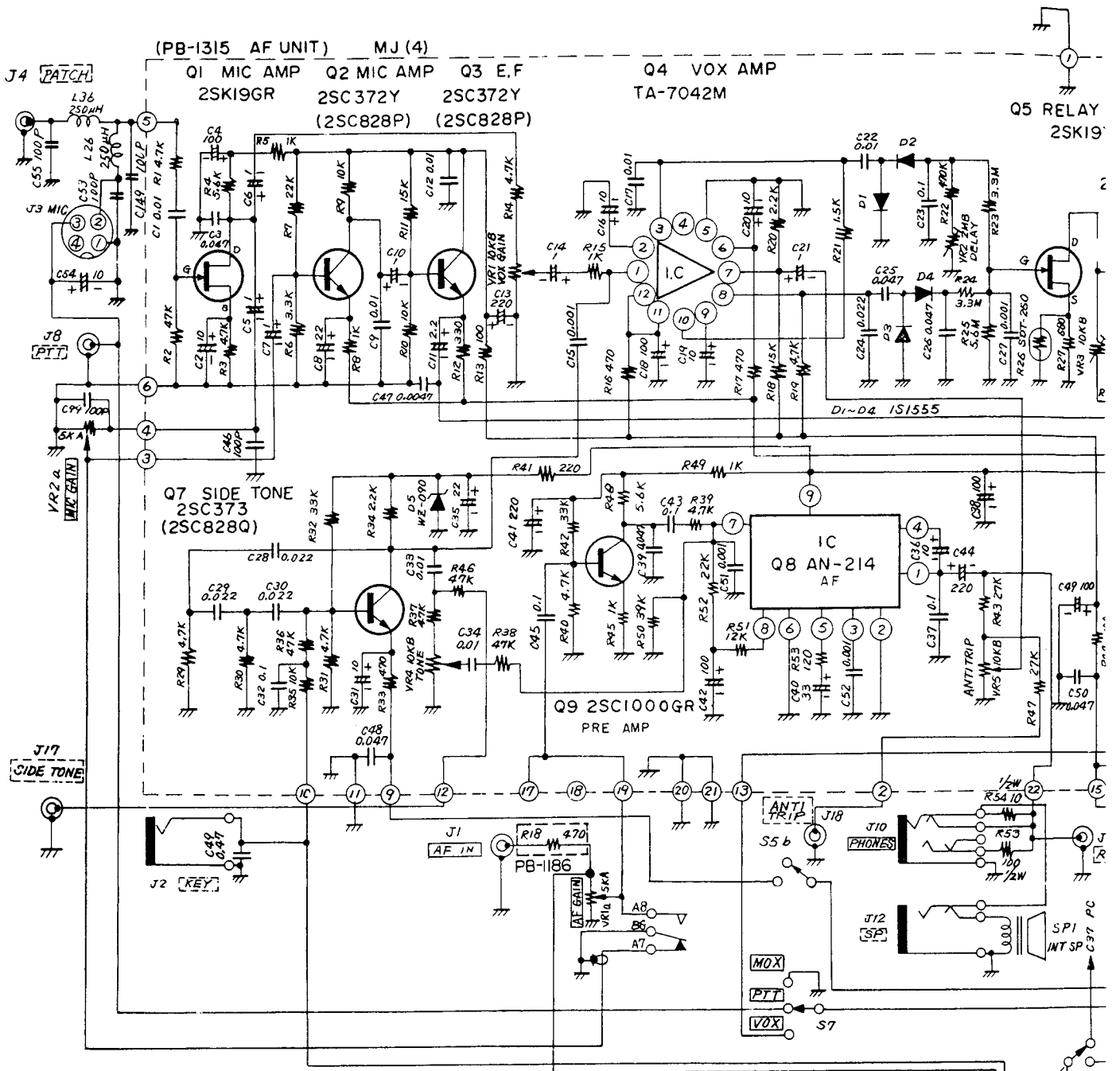

**NOTES**

1. ALL RESISTORS ARE IN 1/4W UNLESS OTHERWISE NOTED.
2. ALL CAPACITORS ARE IN  $\mu$ F UNLESS OTHERWISE NOTED.
3. ALL ELECTROLYTIC CAPACITORS ARE 16WV UNLESS OTHERWISE NOTED.
4. \* VALUE IS NOMINAL.

**FT-101E  
CIRCUIT DIAGRAM**

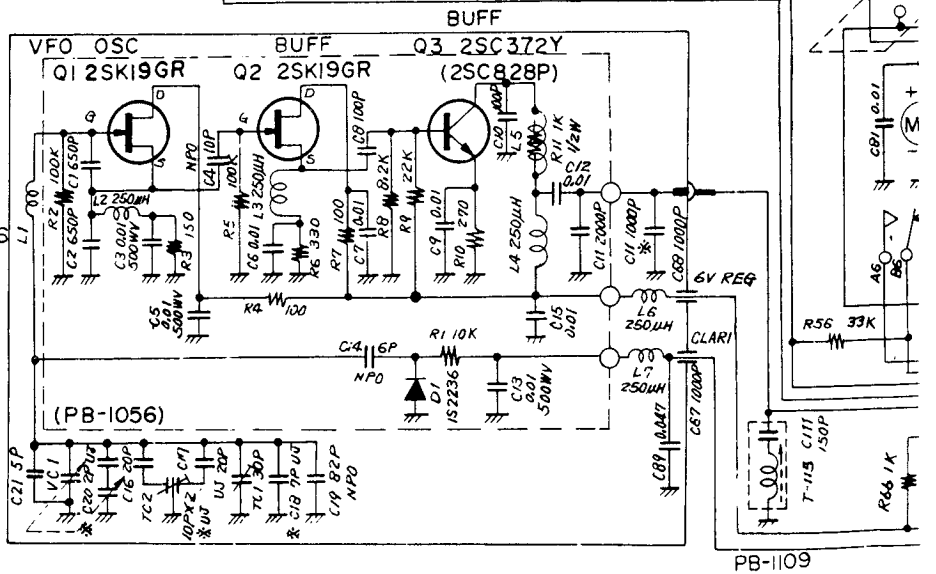

For Service Manuals Contact  
**MAURITRON TECHNICAL SERVICES**  
 8 Cherry Tree Rd, Chinnor  
 Oxon OX9 4QY  
 Tel: 01844-351694 Fax: 01844-352554  
 Email: enquiries@mauritron.co.uk

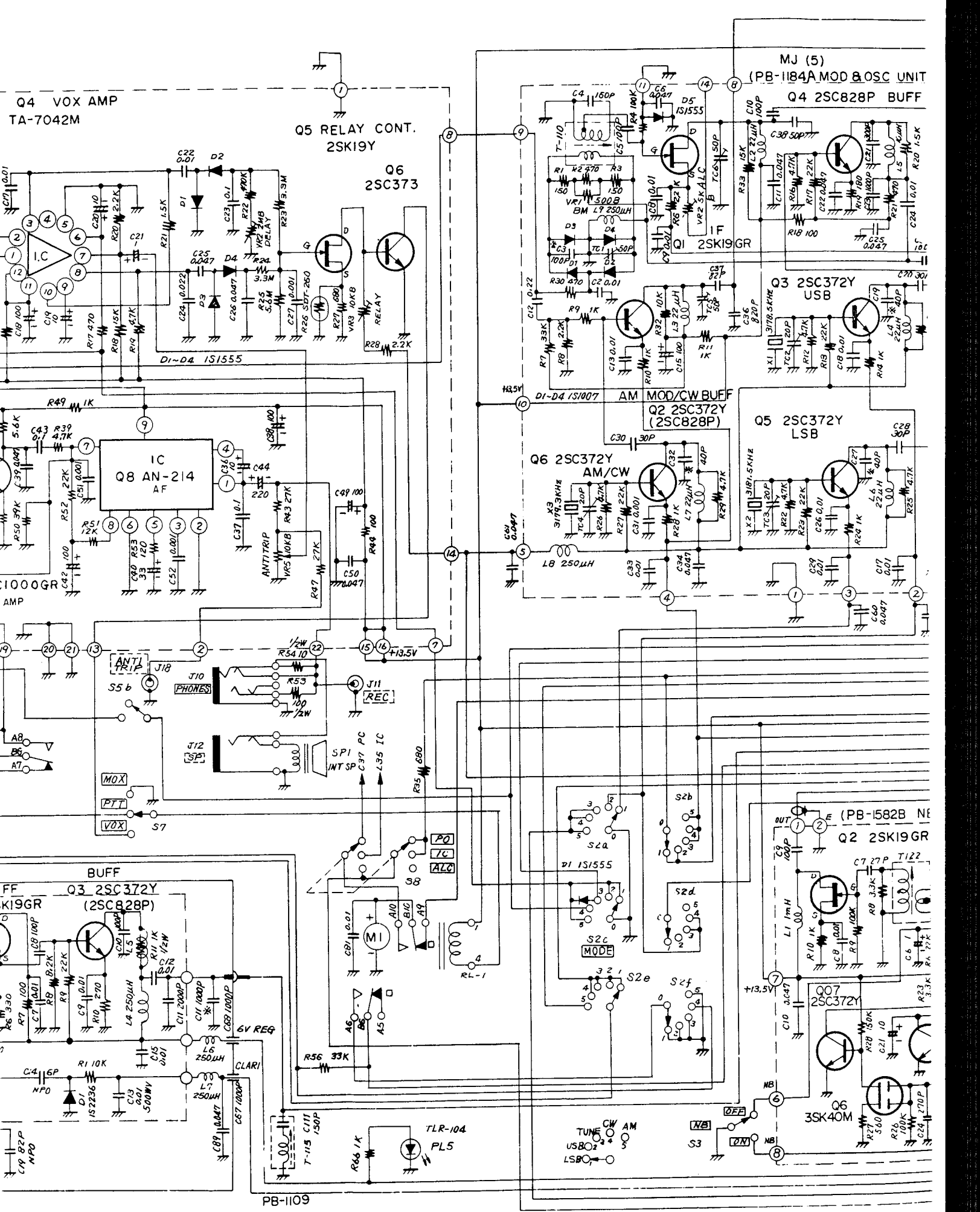

PB-1109

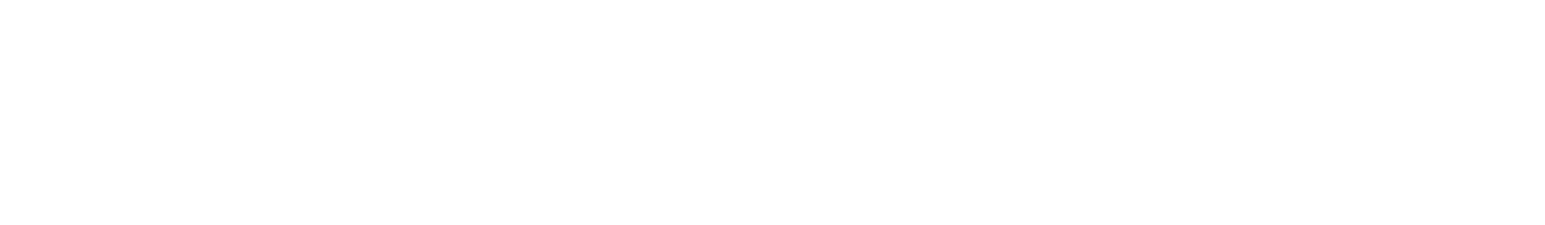
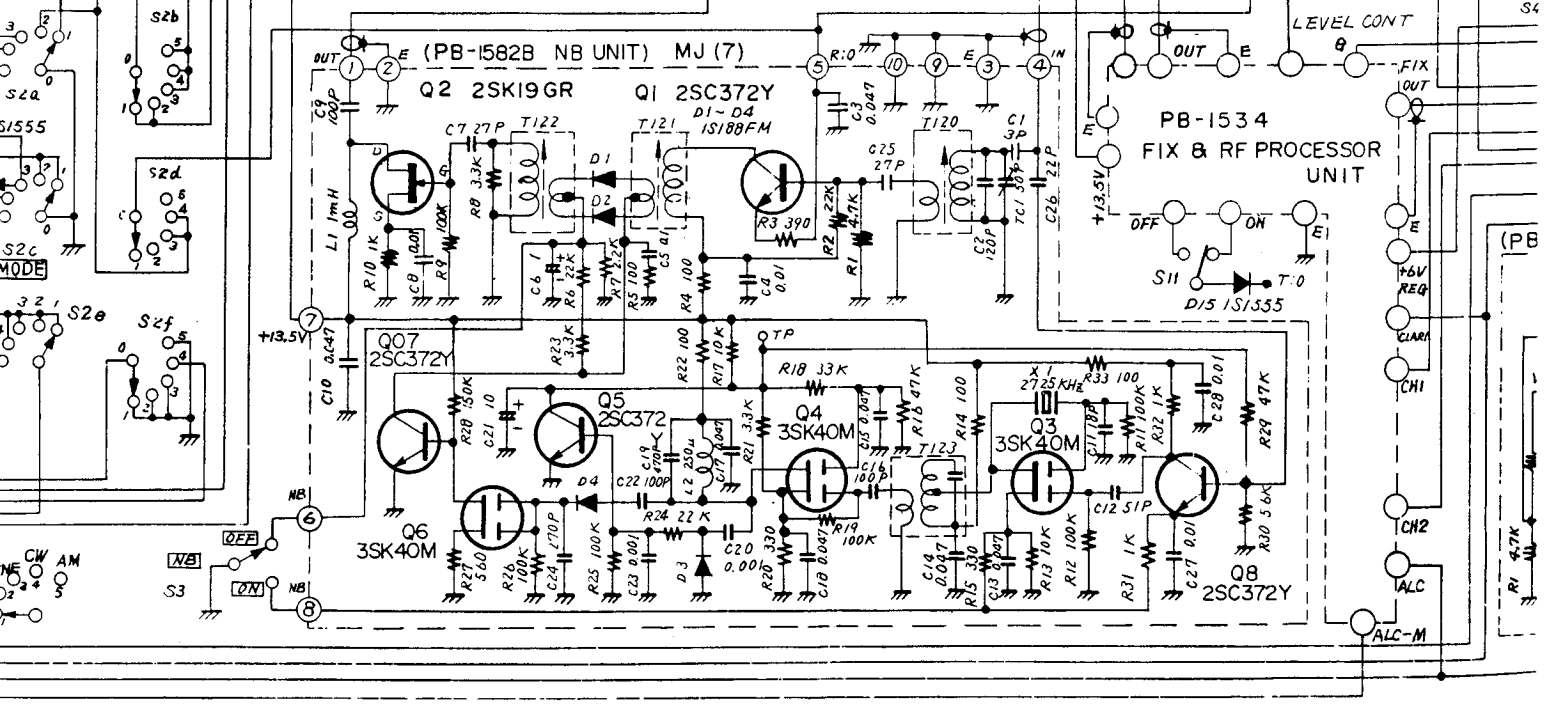
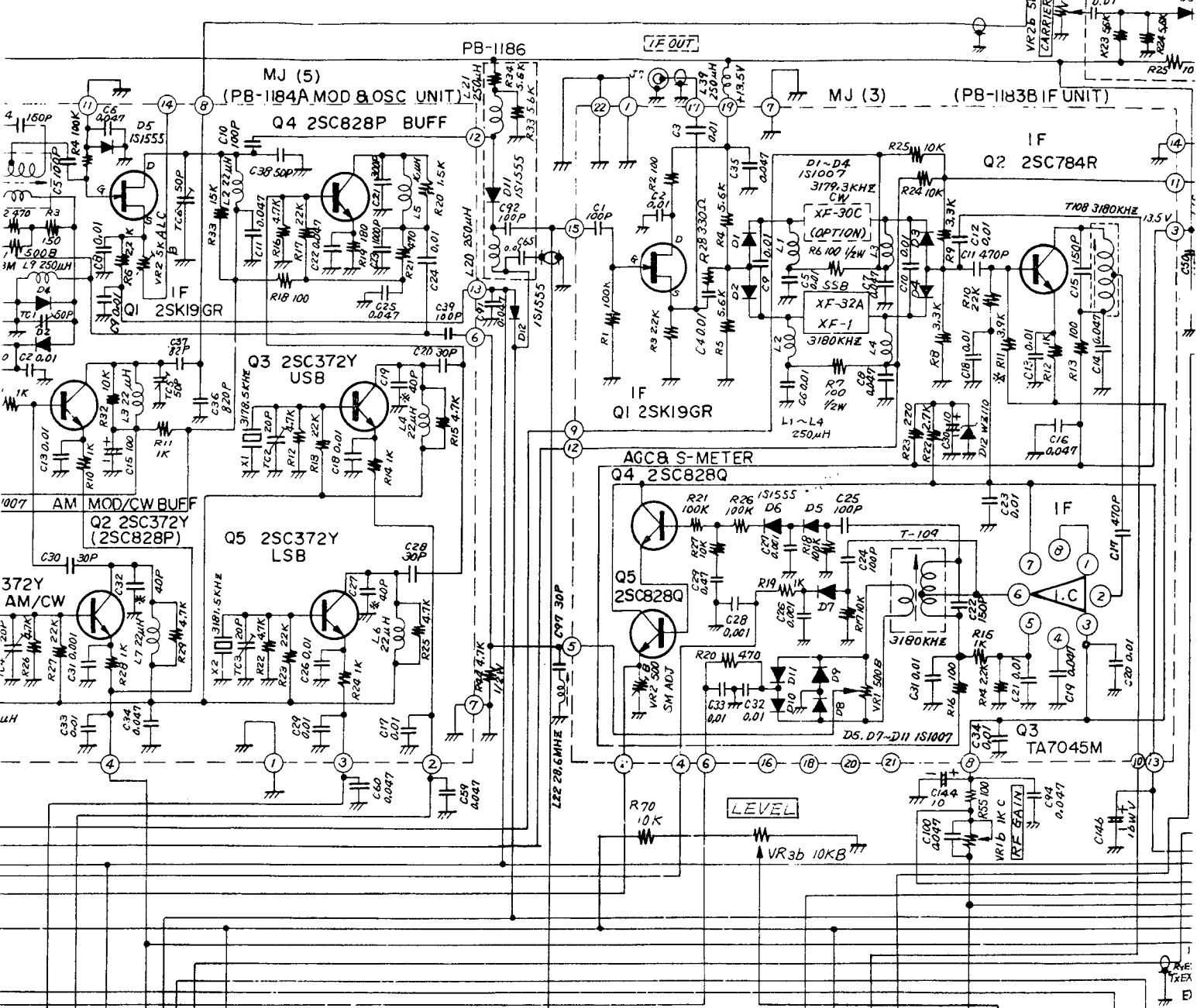

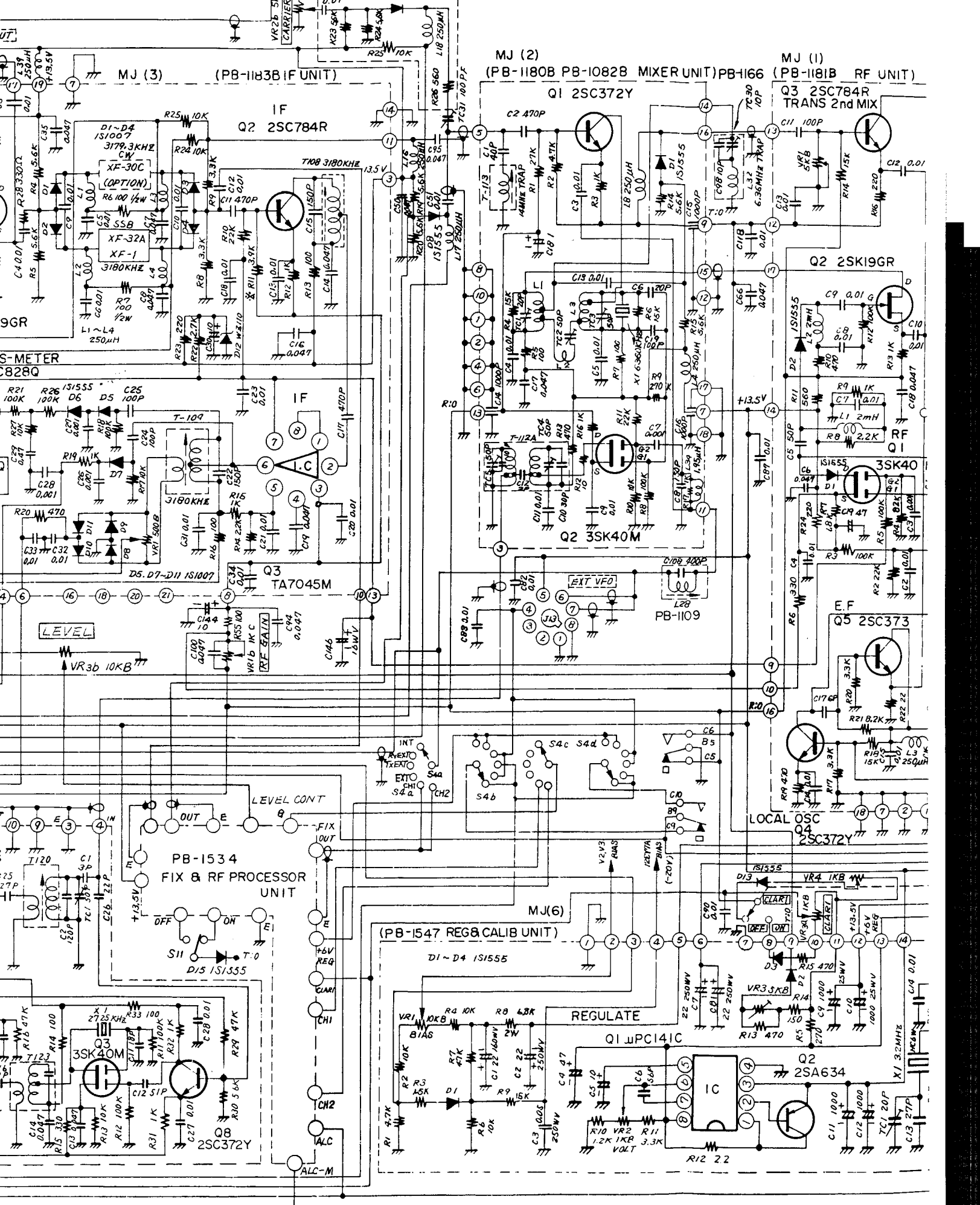

For Service Manuals Contact  
**MAURITRON TECHNICAL SERVICES**  
 8 Cherry Tree Rd, Chinnor  
 Oxon OX9 4QY  
 Tel: 01844-351694 Fax: 01844-352554  
 Email: enquiries@mauritron.co.uk

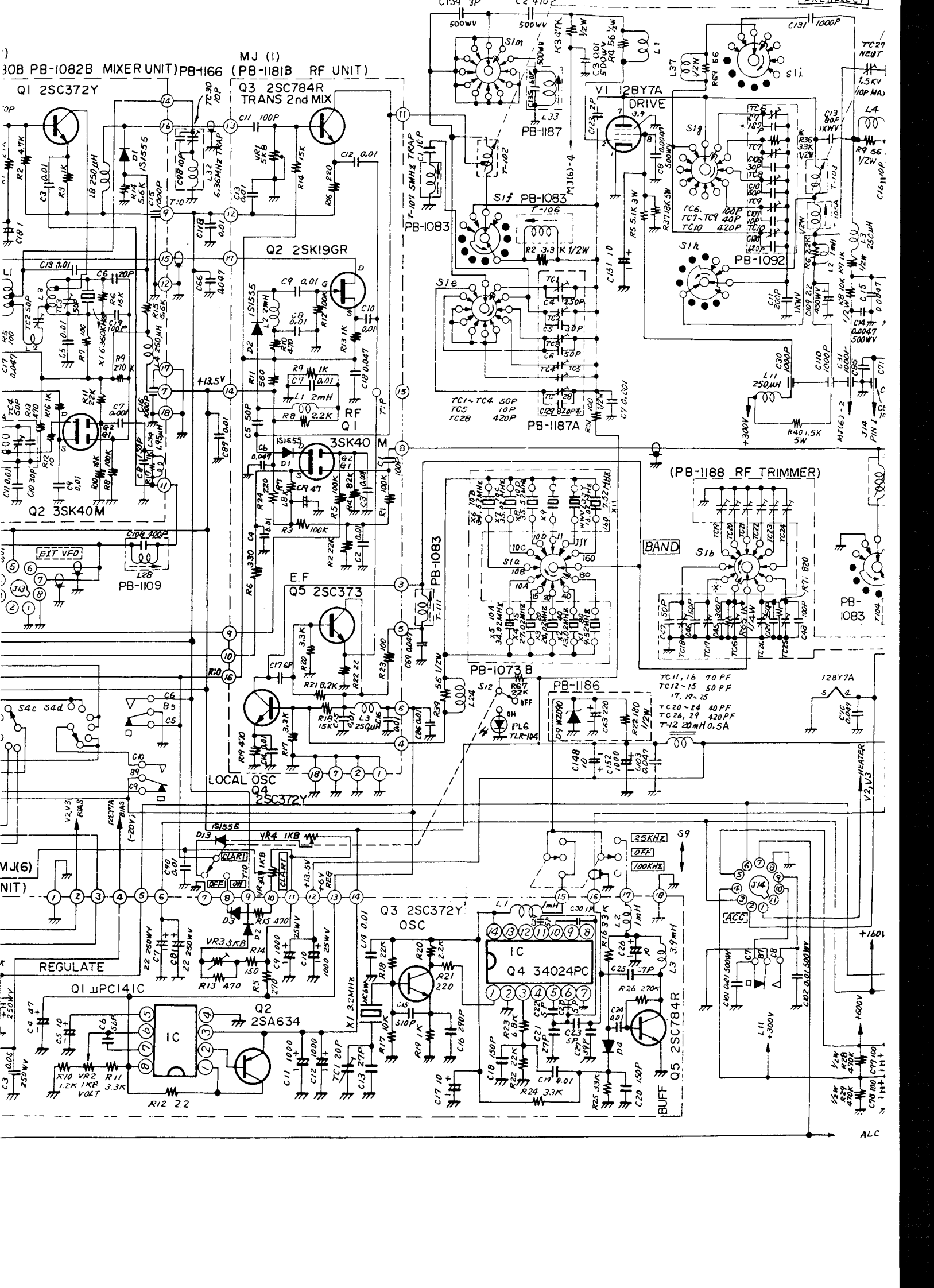



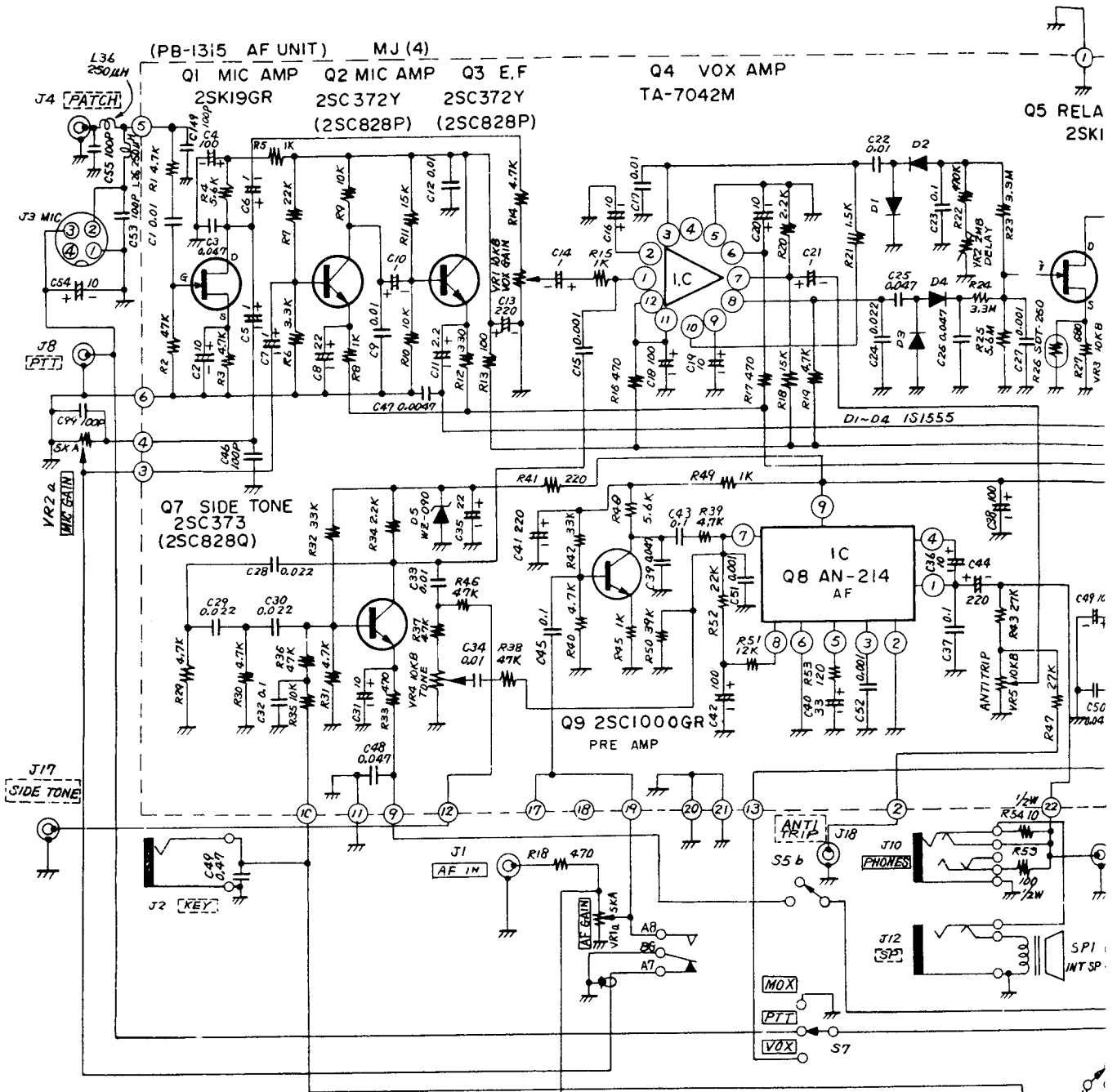

**NOTES**

- 1 ALL RESISTORS ARE IN 1/4W UNLESS OTHERWISE NOTED.
2. ALL CAPACITORS ARE IN  $\mu$ F UNLESS OTHERWISE NOTED.
- 3 ALL ELECTROLYTIC CAPACITORS ARE 16WV UNLESS OTHERWISE NOTED.
- 4 \* VALUE IS NOMINAL.

**FT-101E  
CIRCUIT DIAGRAM**

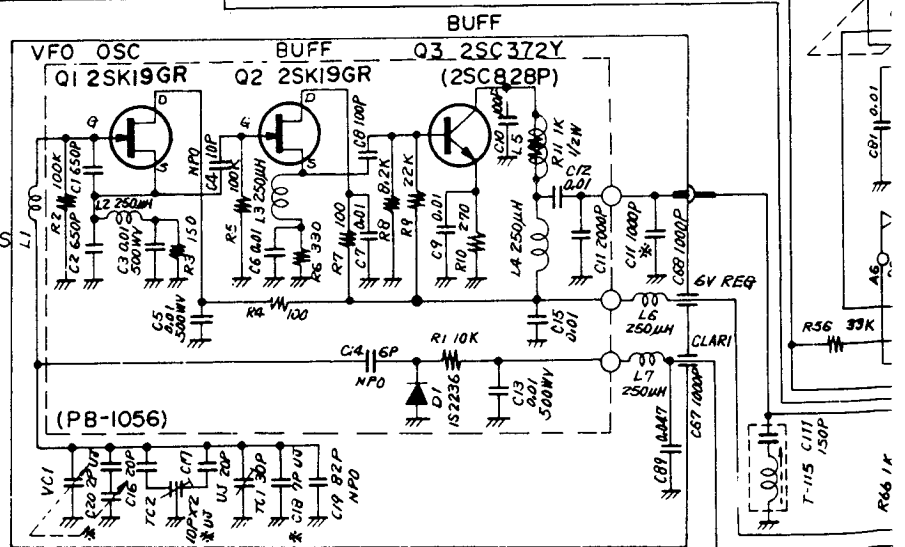

For Service Manuals Contact  
**MAURITRON TECHNICAL SERVICES**  
 8 Cherry Tree Rd, Chinnor  
 Oxon OX9 4QY  
 Tel: 01844-351694 Fax: 01844-352554  
 Email: enquiries@mauritron.co.uk





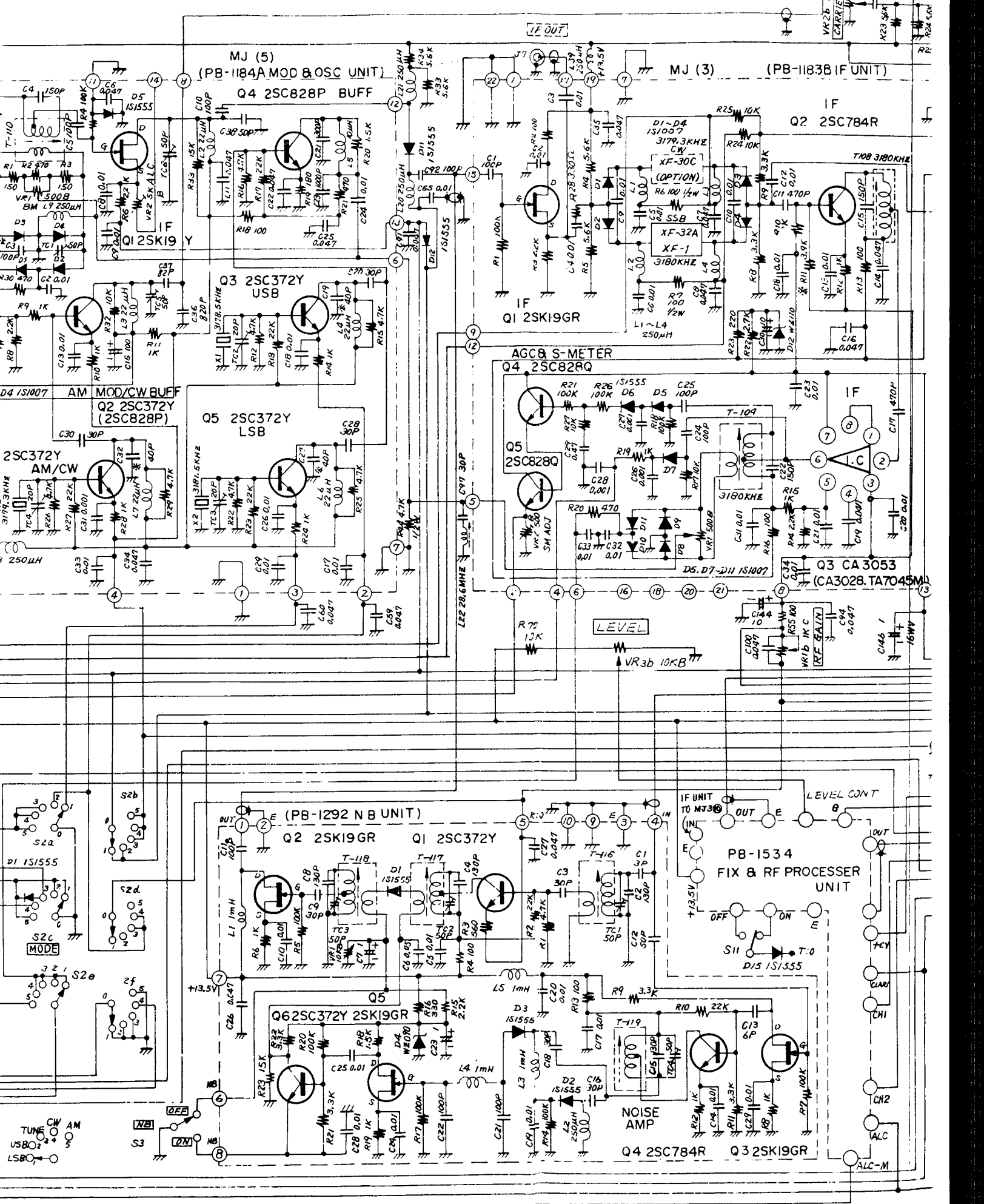

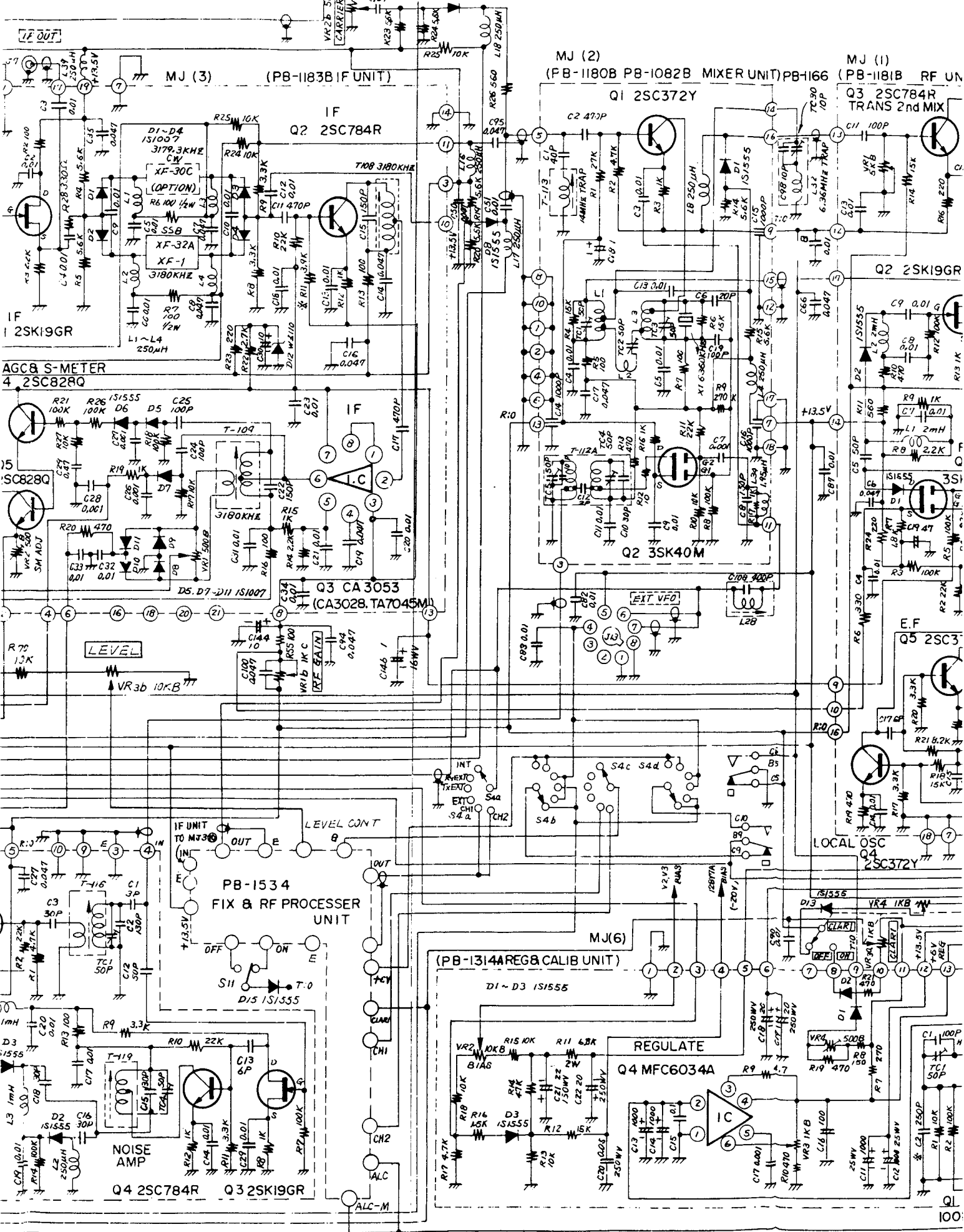

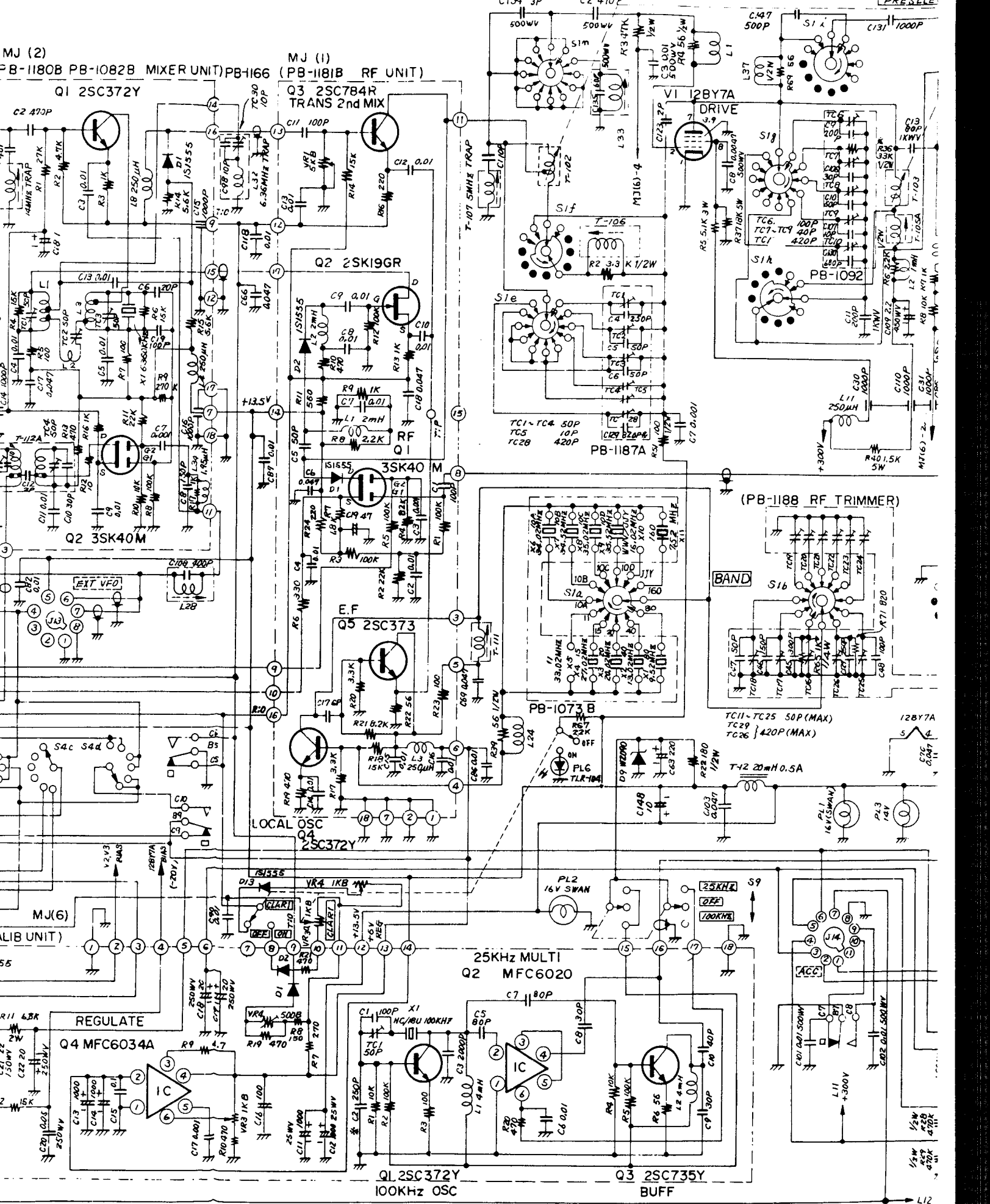

For Service Manuals Contact  
**MAURITRON TECHNICAL SERVICES**  
 8 Cherry Tree Rd, Chinnor  
 Oxon OX9 4QY  
 Tel: 01844-351694 Fax: 01844-352554  
 Email: enquiries@mauritron.co.uk



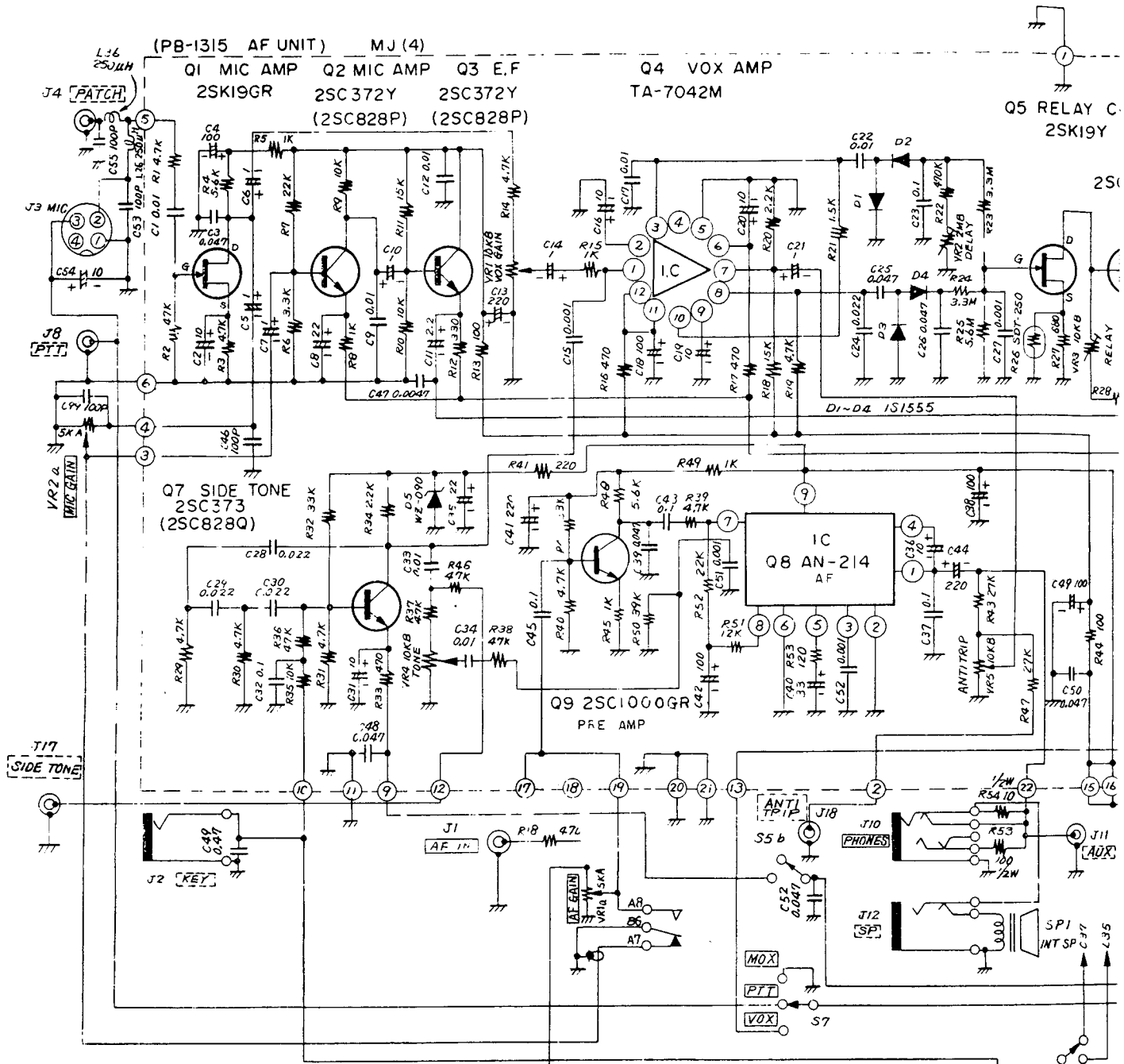

- NOTES
1. ALL RESISTORS ARE IN  $\frac{1}{4}W$  UNLESS OTHERWISE NOTED.
  2. ALL CAPACITORS ARE IN  $\mu F$  UNLESS OTHERWISE NOTED.
  3. ALL ELECTROLYTIC CAPACITORS ARE 16WV UNLESS OTHERWISE NOTED.
  4. \* VALUE IS NOMINAL.

**FT 10IB<sub>2</sub>**  
**CIRCUIT DIAGRAM**

06001

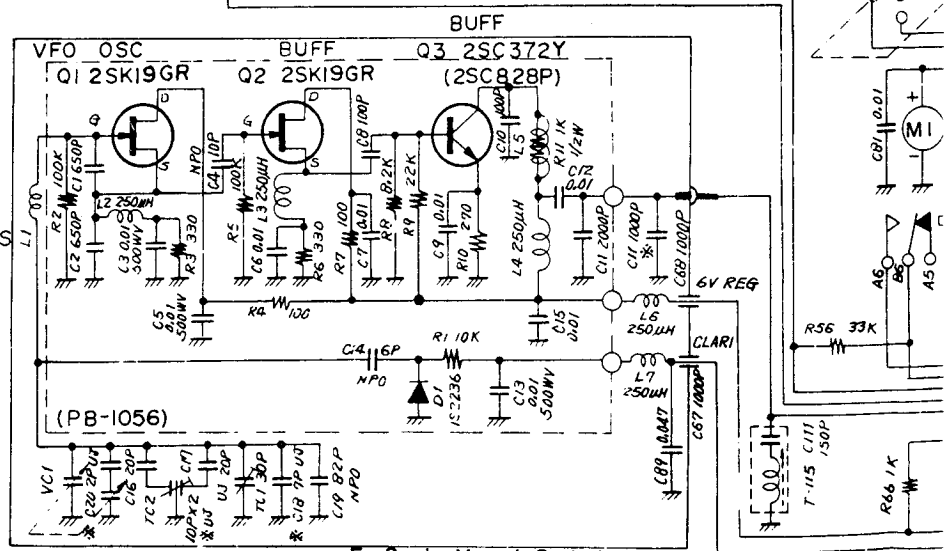

For Service Manuals Contact  
**MAURITRON TECHNICAL SERVICES**  
 8 Cherry Tree Rd, Chinnor  
 Oxon OX9 4QY  
 Tel: 01844-351694 Fax: 01844-352554  
 Email: enquiries@mauritron.co.uk

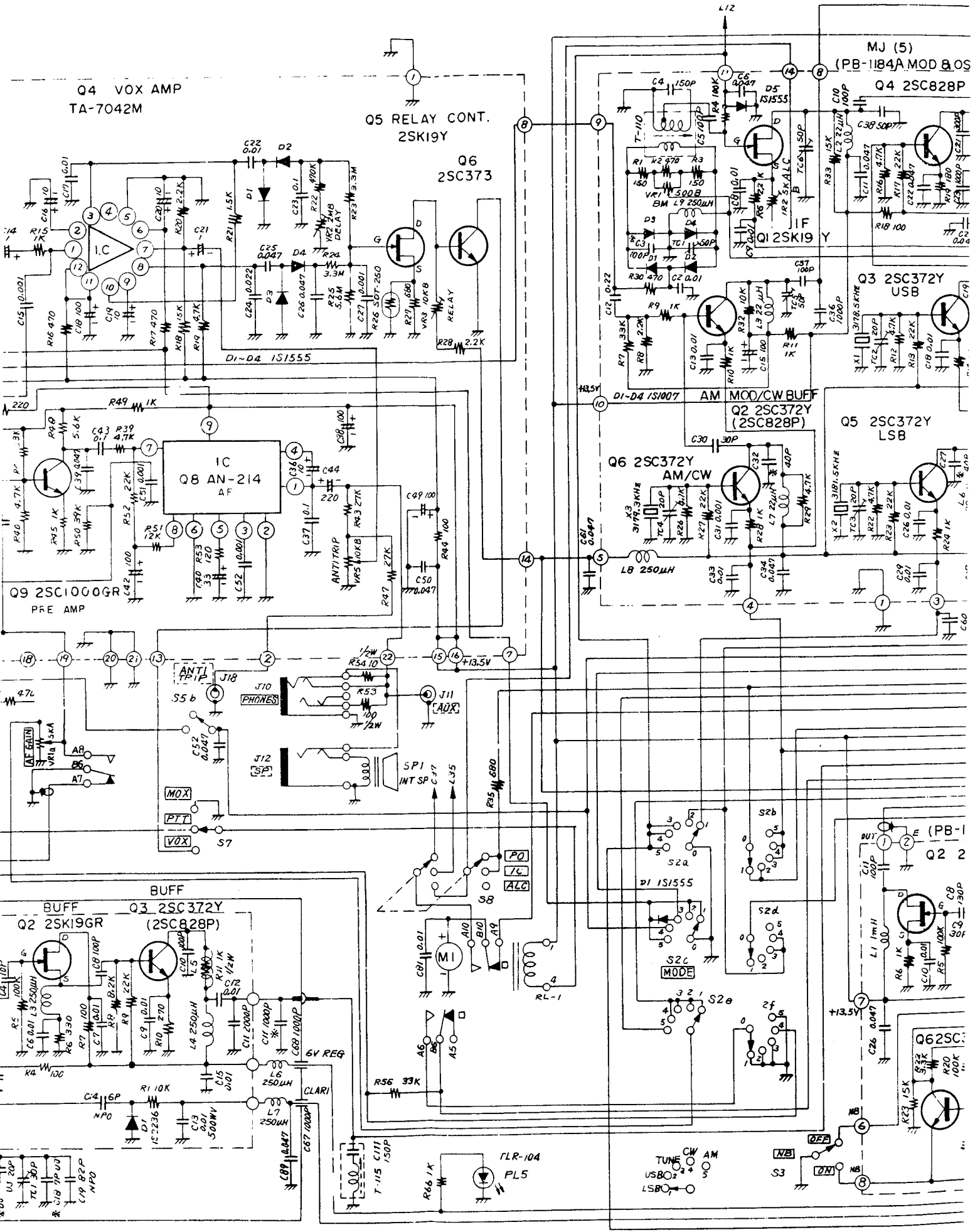

Q4 VOX AMP  
TA-7042M

Q5 RELAY CONT.  
2SK19Y

Q6  
2SC373

MJ (5)  
(PB-1184 MOD & OS)  
Q4 2SC828P

Q3 2SC372Y  
USB

Q5 2SC372Y  
LSB

AM MOD/CW BUFF  
Q2 2SC372Y  
(2SC828P)

Q6 2SC372Y  
AM/CW

Q9 2SC1000GR  
PRE AMP

Q8 AN-214  
AF

Q2 2SK19GR

Q3 2SC372Y  
(2SC828P)

Q2 2

Q6 2SC

Q1 2SK19Y

Q2 2SC

Q3 2SC

Q4 2SC

Q5 2SC

Q6 2SC

Q7 2SC

Q8 2SC

Q9 2SC

Q10 2SC

Q11 2SC

Q12 2SC

Q13 2SC

Q14 2SC

Q15 2SC

Q16 2SC

Q17 2SC

Q18 2SC

Q19 2SC

Q20 2SC

Q21 2SC

Q22 2SC

Q23 2SC

Q24 2SC

Q25 2SC

Q26 2SC

Q27 2SC

Q28 2SC

Q29 2SC

Q30 2SC

Q31 2SC

Q32 2SC

Q33 2SC

Q34 2SC

Q35 2SC

Q36 2SC

Q37 2SC

Q38 2SC

Q39 2SC

Q40 2SC

Q41 2SC

Q42 2SC

Q43 2SC

Q44 2SC

Q45 2SC

Q46 2SC

Q47 2SC

Q48 2SC

Q49 2SC

Q50 2SC

Q51 2SC

Q52 2SC

Q53 2SC

Q54 2SC

Q55 2SC

Q56 2SC

Q57 2SC

Q58 2SC

Q59 2SC

Q60 2SC

Q61 2SC

Q62 2SC

Q63 2SC

Q64 2SC

Q65 2SC

Q66 2SC

Q67 2SC

Q68 2SC

Q69 2SC

Q70 2SC

Q71 2SC

Q72 2SC

Q73 2SC

Q74 2SC

Q75 2SC

Q76 2SC

Q77 2SC

Q78 2SC

Q79 2SC

Q80 2SC

Q81 2SC

Q82 2SC

Q83 2SC

Q84 2SC

Q85 2SC

Q86 2SC

Q87 2SC

Q88 2SC

Q89 2SC

Q90 2SC

Q91 2SC

Q92 2SC

Q93 2SC

Q94 2SC

Q95 2SC

Q96 2SC

Q97 2SC

Q98 2SC

Q99 2SC

Q100 2SC

Q101 2SC

Q102 2SC

Q103 2SC

Q104 2SC

Q105 2SC

Q106 2SC

Q107 2SC

Q108 2SC

Q109 2SC

Q110 2SC

Q111 2SC

Q112 2SC

Q113 2SC

Q114 2SC

Q115 2SC

Q116 2SC

Q117 2SC

Q118 2SC

Q119 2SC

Q120 2SC

Q121 2SC

Q122 2SC

Q123 2SC

Q124 2SC

Q125 2SC

Q126 2SC

Q127 2SC

Q128 2SC

Q129 2SC

Q130 2SC

Q131 2SC

Q132 2SC

Q133 2SC

Q134 2SC

Q135 2SC

Q136 2SC

Q137 2SC

Q138 2SC

Q139 2SC

Q140 2SC

Q141 2SC

Q142 2SC

Q143 2SC

Q144 2SC

Q145 2SC

Q146 2SC

Q147 2SC

Q148 2SC

Q149 2SC

Q150 2SC

Q151 2SC

Q152 2SC

Q153 2SC

Q154 2SC

Q155 2SC

Q156 2SC

Q157 2SC

Q158 2SC

Q159 2SC

Q160 2SC

Q161 2SC

Q162 2SC

Q163 2SC

Q164 2SC

Q165 2SC

Q166 2SC

Q167 2SC

Q168 2SC

Q169 2SC

Q170 2SC

Q171 2SC

Q172 2SC

Q173 2SC

Q174 2SC

Q175 2SC

Q176 2SC

Q177 2SC

Q178 2SC

Q179 2SC

Q180 2SC

Q181 2SC

Q182 2SC

Q183 2SC

Q184 2SC

Q185 2SC

Q186 2SC

Q187 2SC

Q188 2SC

Q189 2SC

Q190 2SC

Q191 2SC

Q192 2SC

Q193 2SC

Q194 2SC

Q195 2SC

Q196 2SC

Q197 2SC

Q198 2SC

Q199 2SC

Q200 2SC

Q201 2SC

Q202 2SC

Q203 2SC

Q204 2SC

Q205 2SC

Q206 2SC

Q207 2SC

Q208 2SC

Q209 2SC

Q210 2SC

Q211 2SC

Q212 2SC

Q213 2SC

Q214 2SC

Q215 2SC

Q216 2SC

Q217 2SC

Q218 2SC

Q219 2SC

Q220 2SC

Q221 2SC

Q222 2SC

Q223 2SC

Q224 2SC

Q225 2SC

Q226 2SC

Q227 2SC

Q228 2SC

Q229 2SC

Q230 2SC

Q231 2SC

Q232 2SC

Q233 2SC

Q234 2SC

Q235 2SC

Q236 2SC

Q237 2SC

Q238 2SC

Q239 2SC

Q240 2SC

Q241 2SC

Q242 2SC

Q243 2SC

Q244 2SC

Q245 2SC

Q246 2SC

Q247 2SC

Q248 2SC

Q249 2SC

Q250 2SC

Q251 2SC

Q252 2SC

Q253 2SC

Q254 2SC

Q255 2SC

Q256 2SC

Q257 2SC

Q258 2SC

Q259 2SC

Q260 2SC

Q261 2SC

Q262 2SC

Q263 2SC

Q264 2SC

Q265 2SC

Q266 2SC

Q267 2SC

Q268 2SC

Q269 2SC

Q270 2SC

Q271 2SC

Q272 2SC

Q273 2SC

Q274 2SC

Q275 2SC

Q276 2SC

Q277 2SC

Q278 2SC

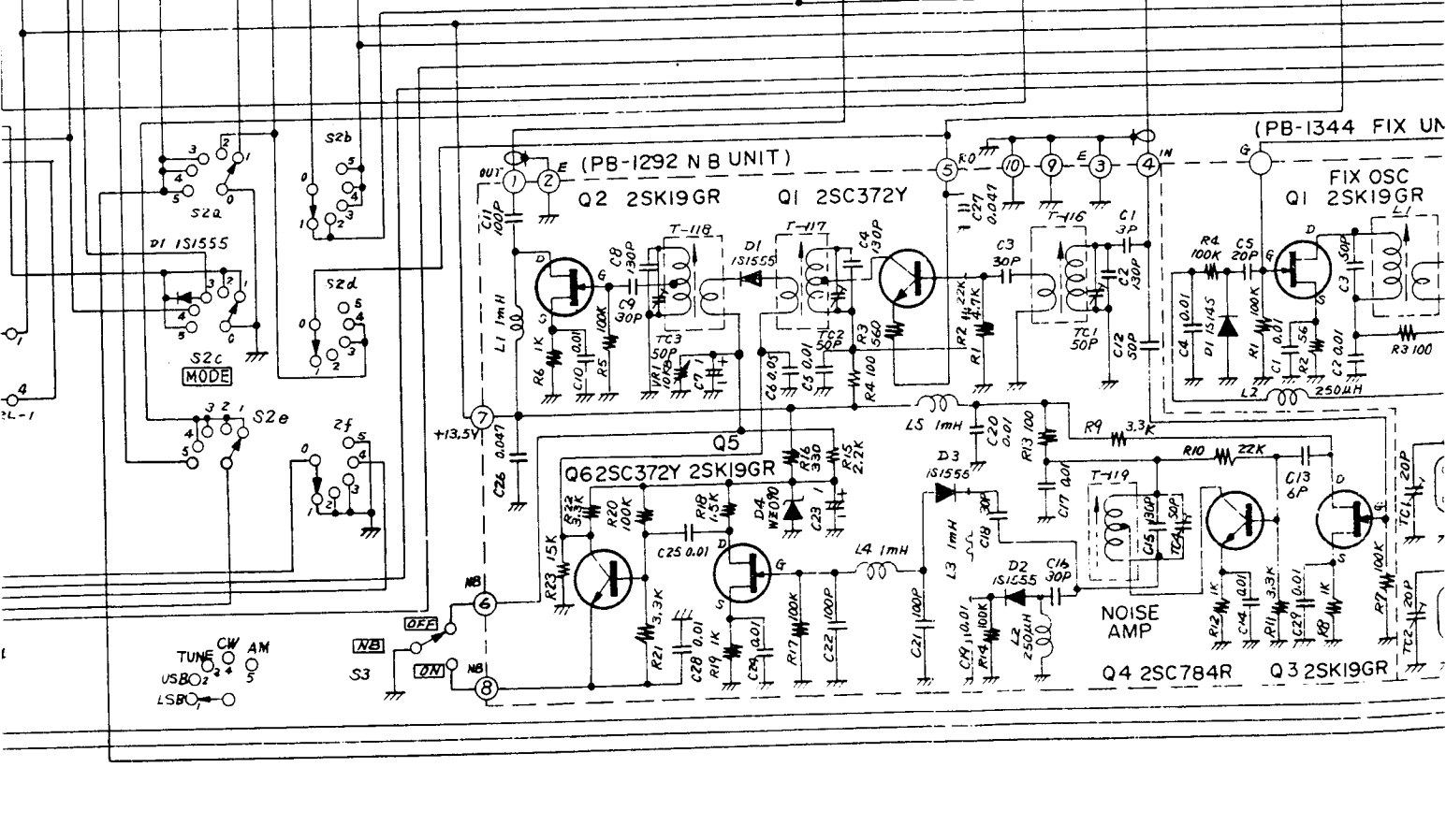
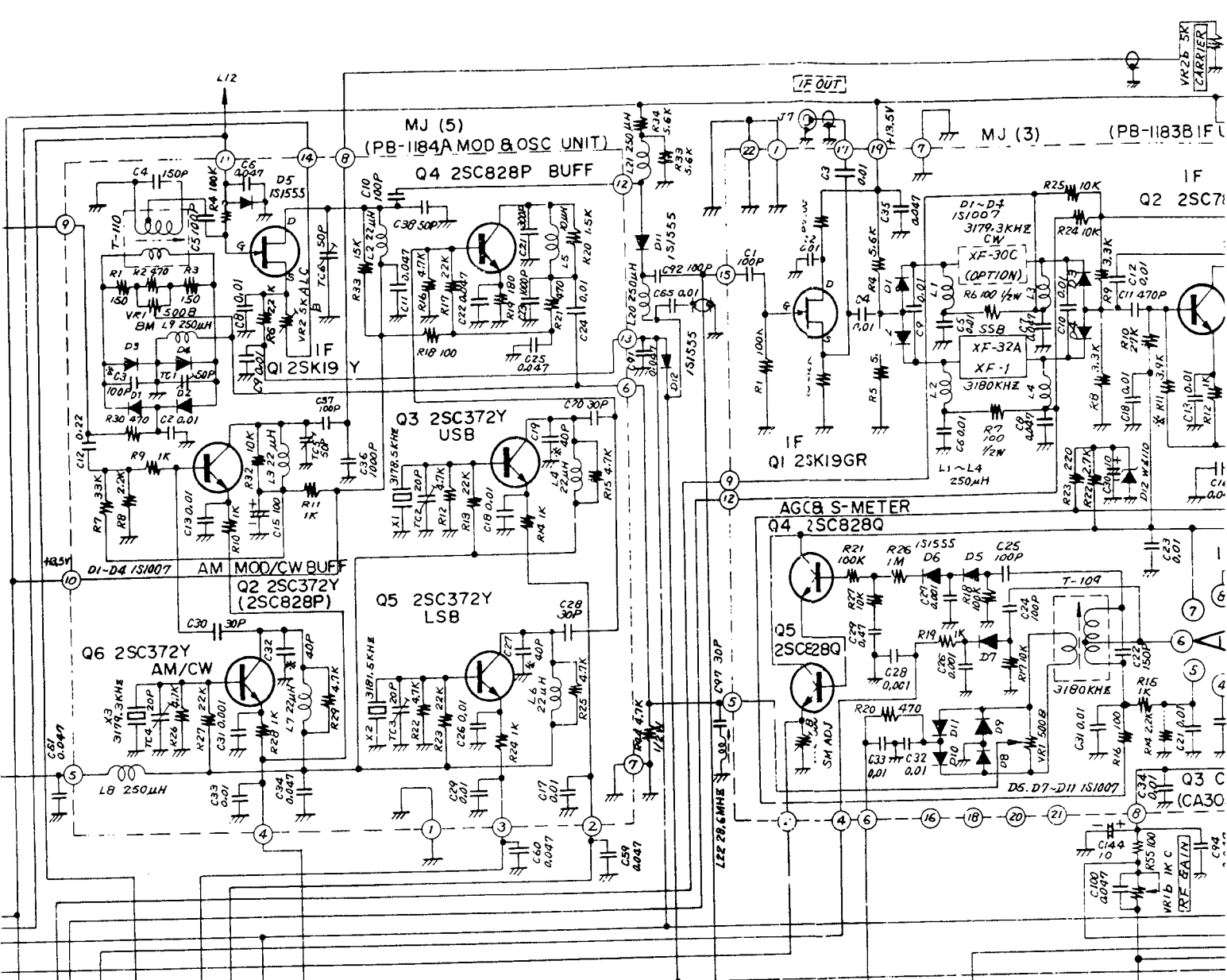

TUNE CW AM  
USB 2 5  
LSB 7

VR26 5K  
CARRIER

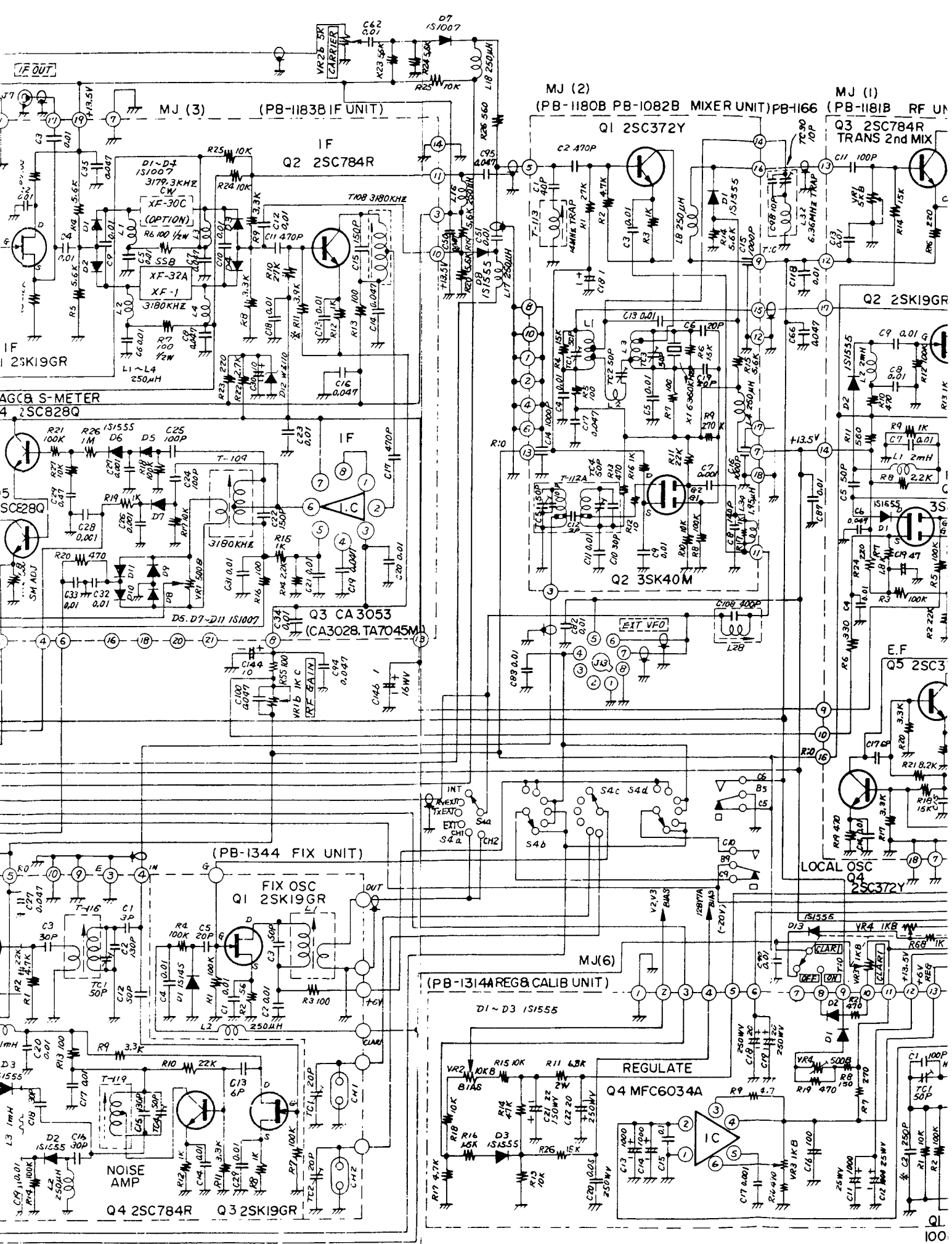

For Service Manuals Contact  
**MAURITRON TECHNICAL SERVICES**  
 8 Cherry Tree Rd, Chinnor  
 Oxon OX9 4QY  
 Tel: 01844-351694 Fax: 01844-352554  
 Email: enquiries@mauritron.co.uk



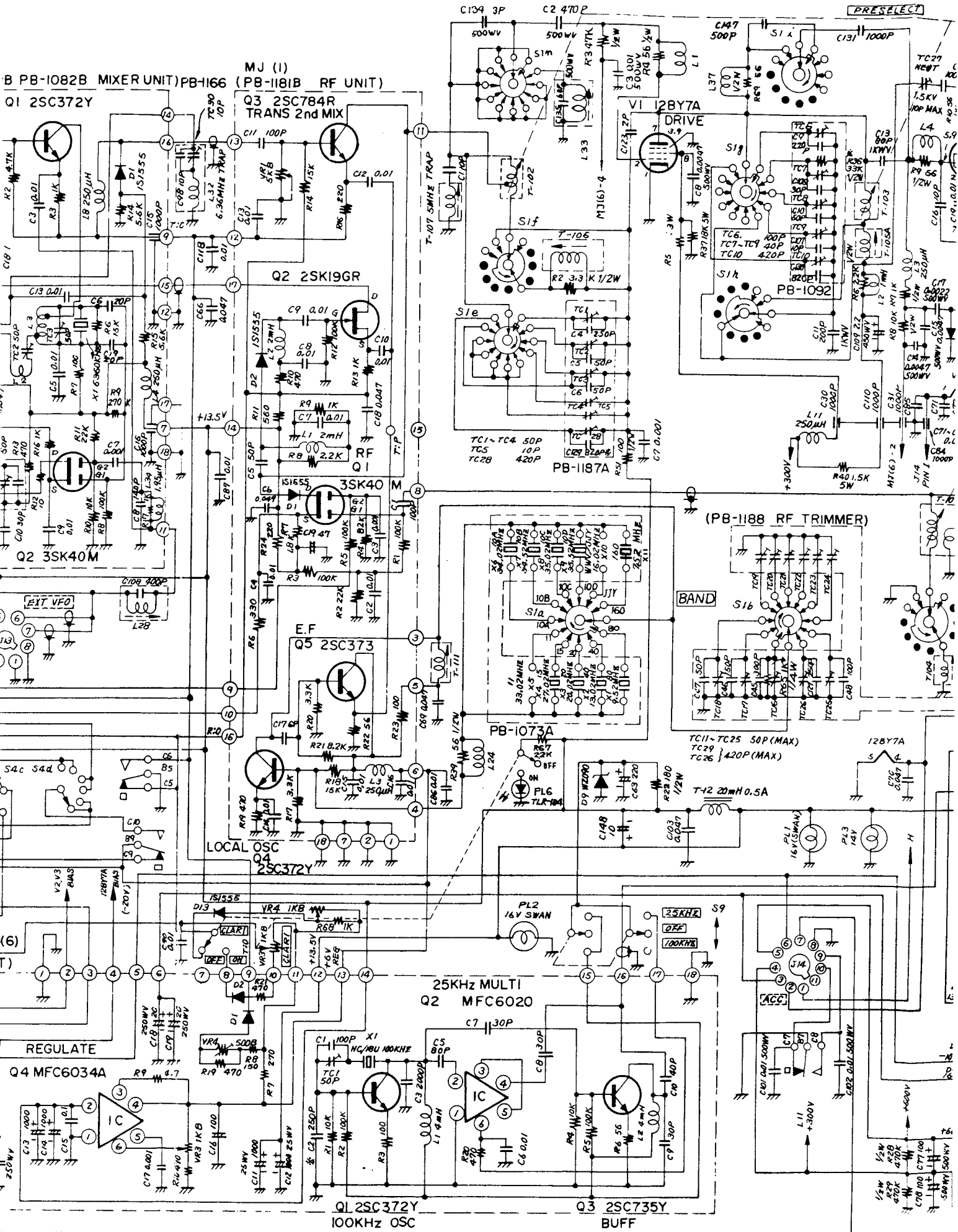

B PB-1082B MIXER UNIT) PB-1166 (PB-1181B RF UNIT)

Q1 2SC372Y

MJ (I)  
Q3 2SC784R  
TRANS 2nd MIX

Q2 3SK40M

Q2 2SK19GR

3SK40M

Q5 2SC373

Q4 MFC6034A

25KHZ MULTI  
Q2 MFC6020

Q1 2SC372Y  
100KHZ OSC

Q3 2SC735Y  
BUFF

PRESELECT

DRIVE  
VI 12BY7A

PB-1092

PB-1187A

(PB-1188 RF TRIMMER)

PB-1073A

BAND

TC11-TC25 50P(MAX)  
TC29  
TC26 {420P(MAX)

T-42 20mH 0.5A

REGULATE

1.5KV 100pF

1.5KV 100pF

1.5KV 100pF

1.5KV 100pF

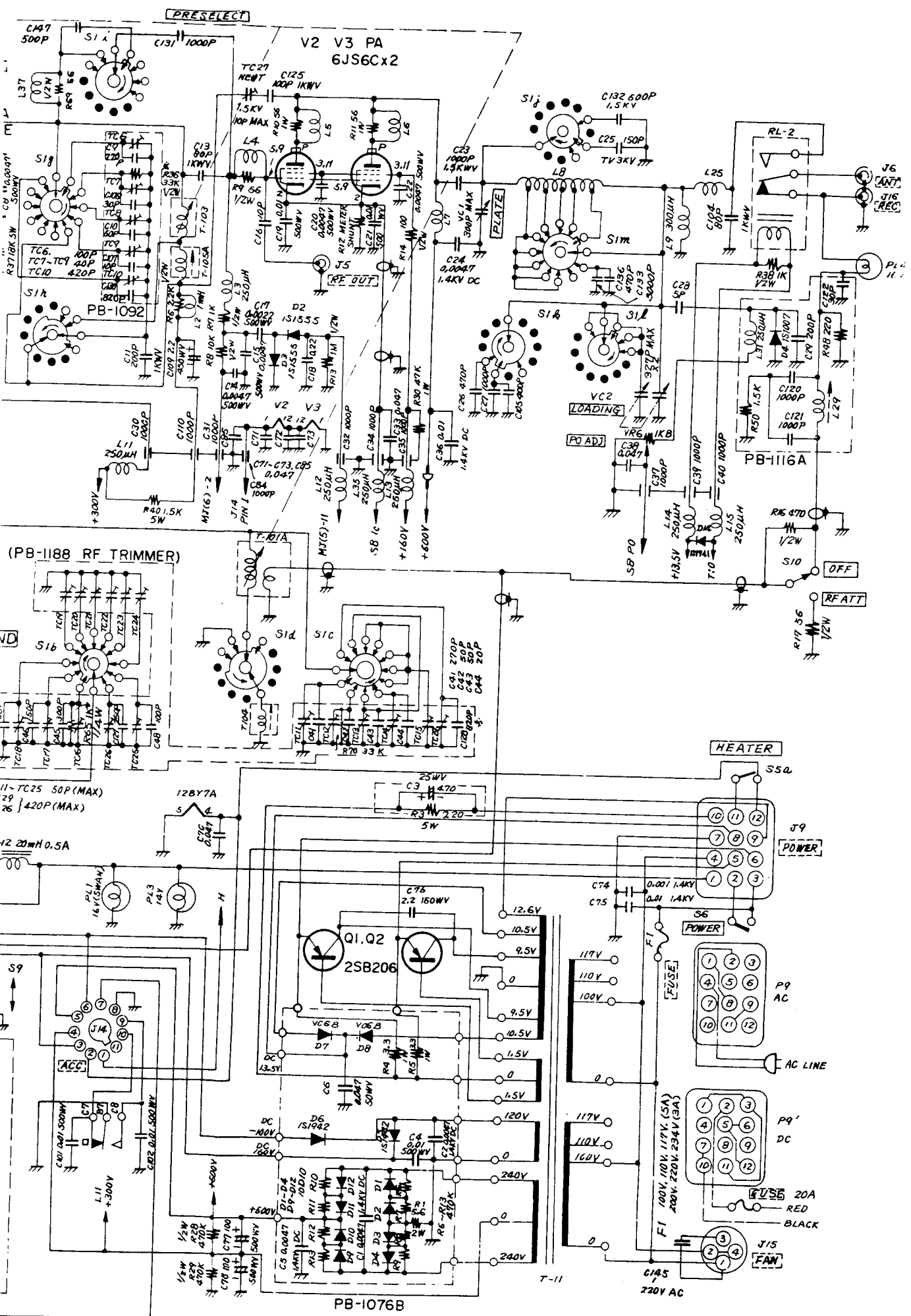

For Service Manuals Contact  
**MAURITRON TECHNICAL SERVICES**  
 8 Cherry Tree Rd, Chinnor  
 Oxon OX9 4QY  
 Tel: 01844-351694 Fax: 01844-352554  
 Email: enquires@mauritron.co.uk